

INTEGRATED PLENUM with "RAPITACH" MOUNTING PLATE

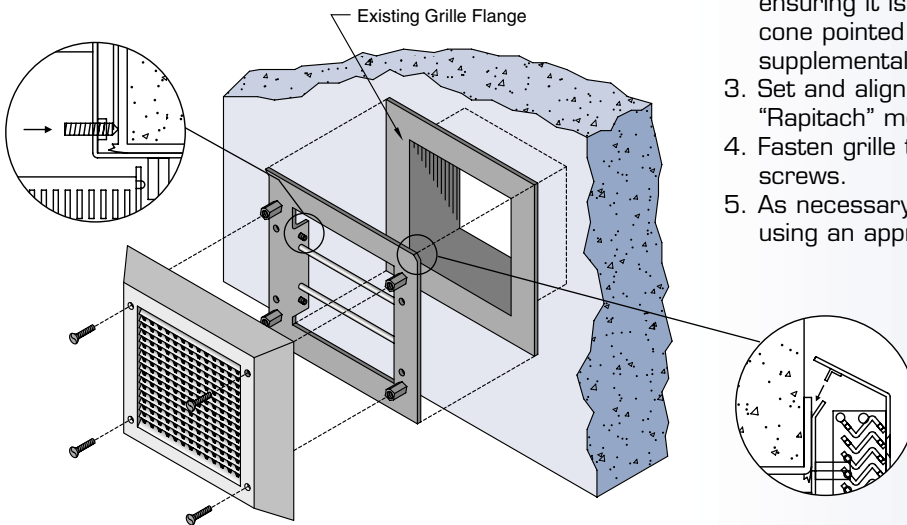

S-VENT® MODELS SV2, SV3, and SV6

1. Cut out the existing grille face, while leaving the face flange and sleeve in place.
2. Insert "Rapitach" mounting plate into existing grille ensuring it is properly orientated and secure with the cone pointed setscrews supplied. Holes supplied for supplemental welded attachments.
3. Set and align the grille (with integrated plenum) to the "Rapitach" mounting plate.
4. Fasten grille to plate using approved tamperproof screws.
5. As necessary, seal any gaps around the faceplate using an approved security sealant.

INTEGRATED PLENUM with FACE MOUNTED GRILLE

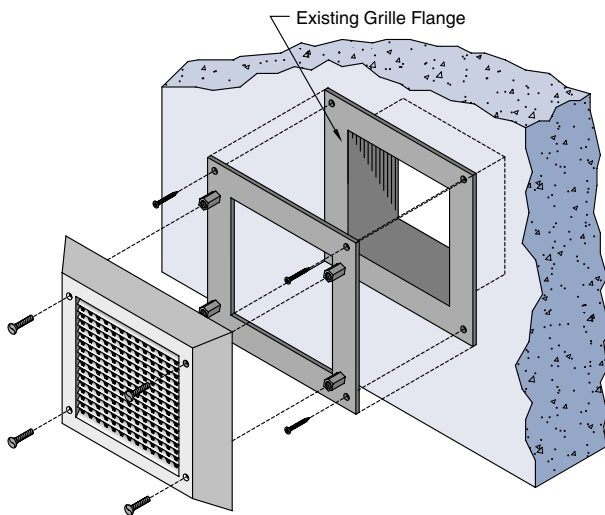

S-VENT® MODELS SV2, SV3, and SV6

1. For more efficient air flow, cut out the existing grille face. Leave all else in place.
2. Attach the mounting plate using screws (by others) or by welding.
3. Fasten grille to plate using approved tamperproof screws.
4. As necessary, seal any gaps around the faceplate using an approved security sealant.

FACE MOUNTED GRILLE and PLATE

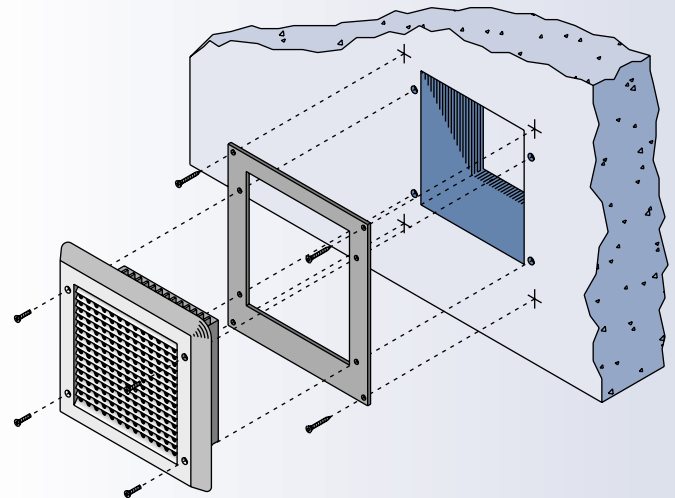

S-VENT® MODELS SV2, SV3, and SV6

1. Attach the mounting plate using screws (by others) or by welding.
2. Fasten grille to plate using approved tamperproof screws.
3. As necessary, seal any gaps around the faceplate using an approved security sealant.

NOTE: To maximize sealant use, prepare enough plenum rough-ins so that a full tube of caulking can be used.

IMPORTANT It is the specifier's responsibility to properly configure the HVAC system to meet the appropriate level of comfort, safety, security and detention