

S-VENT[®]

SUBMITTAL SHEET



1220 WATSONCENTER ROAD • CARSON, CA 90745-4206
 (310) 835-7500 • FAX (310) 835-0448
 e-mail: airsec@anemostat.com • website: www.anemostat-hvac.com

SV3-__-PC

SPECIFY TYPE
MAXIMUM SECURITY GRILLE
 7/16" X 3/16" OPENING
 with
 ANCHOR STUDS FOR
 PRECAST CONCRETE

TOP SECTION

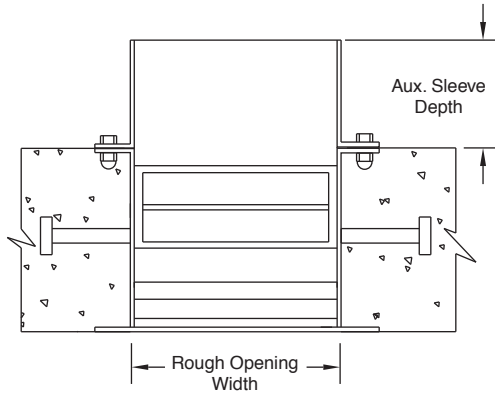

FRONT SECTION

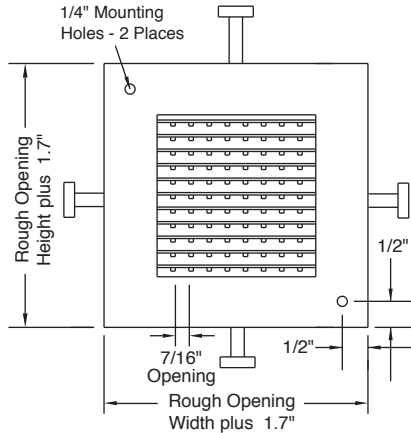

SIDE SECTION

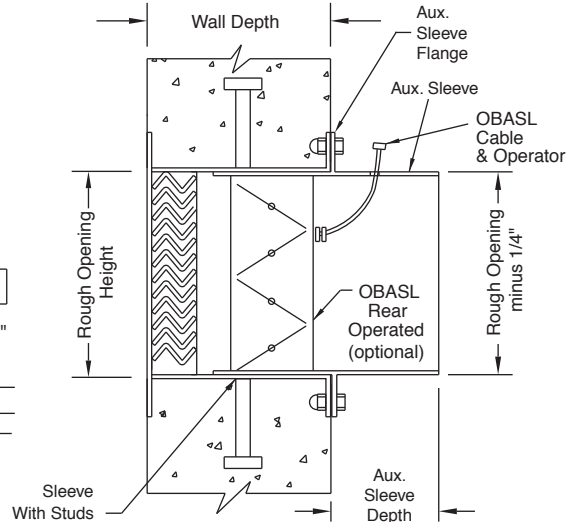

IMPORTANT: It is the specifier's responsibility to properly configure the HVAC system to meet the appropriate level of comfort, safety, security and detention

PRODUCT FEATURES

Face Flange

14 GA (standard)

Material Type

Cold Rolled Steel (standard)

Horizontal Louvers/Vertical Mullions

14 GA with 1 7/16" Neck Depth (std)

Finish

White Powder Coat (std)

Other Powder Coat Colors _____

Sleeve (standard)

14 GA - specify length _____

Auxiliary Sleeve with Flange (optional)

14 GA - specify length _____

Opposed Blade Damper (optional)
 (shipped loose)

Rear Operated with ASL Cable

Anchoring Studs (standard)

Nelson Type - specify stud size _____

MUST **SPECIFY TYPE** (BASED ON ROUGH OPENING SIZE)
 AS PART OF MODEL NUMBER WHEN PLACING ORDER

ROUGH OPENING SIZES (WIDTH X HEIGHT)

Dimensions in Inches	WIDTH									
	6.3	8.3	10.3	12.3	14.3	16.3	18.3	20.3	22.3	
HEIGHT	6.3	A1□	B1□	C1□	D1□	E1□	F1□	G1□	H1□	J1□
	8.3	A2□	B2□	C2□	D2□	E2□	F2□	G2□	H2□	J2□
	10.3	A3□	B3□	C3□	D3□	E3□	F3□	G3□	H3□	J3□
	12.3	A4□	B4□	C4□	D4□	E4□	F4□	G4□	H4□	J4□
	14.3	A5□	B5□	C5□	D5□	E5□	F5□	G5□	H5□	J5□
	16.3	A6□	B6□	C6□	D6□	E6□	F6□	G6□	H6□	J6□
	18.3	A7□	B7□	C7□	D7□	E7□	F7□	G7□	H7□	J7□
	20.3	A8□	B8□	C8□	D8□	E8□	F8□	G8□	H8□	J8□
	22.3	A9	B9	C9	D9	E9	F9	G9	H9	J9

QTY	TYPE	ROUGH OPENING W" X H"		WALL DEPTH
27	C3	10.3	10.3	6"

SUBMITTAL APPROVAL

Job Name and Location			
Engineer	Date	Factory	Date
Mfr. Rep.	Date	Submitted By	Date

MARCH 2015
 NEW CONSTRUCTION
 S-VENT SECURITY PRODUCTS PAGE 6