

## PRODUCT FEATURES

### CHDL-1F (Inverted V, frame one side)

- 18 GA. Frame, 22 GA. Grille Blades
- Installs with stops on one side and a flange that screws into the face of the door on the opposite side
- Vision proof

### DRDL (Double Inverted V, Darkroom)

- 18 GA. Frame, 20 GA. Grille Blades
- Installs with screws directly into the door
- For Darkroom applications where light cannot be present
- Flat black finish reduces light transmission.

### FDLS (Inverted Split Y)

- 18 GA. Frame and Grille Blades
- Installs by means of sheet metal or wood screws directly into the door
- Will fit any door thickness over 1-1/8"
- Vision Proof

## SPECIAL FEATURES

- Arctic White baked-on finish (DRDL flat black)
- Custom Baked Enamel Colors (Color/Wood Stained Chip required for paint match)
- Security Screw Fasteners
- Mesh Screens
- #304, or #316 Stainless Steel #4 Finish (satin)
- Galvanized Sheet Metal
- Aluminum #5052 (mill finish or anodized)

**NOTE:** For Exterior use, High Humidity or Salt Air Application, product must be Galvanized or Stainless Steel.

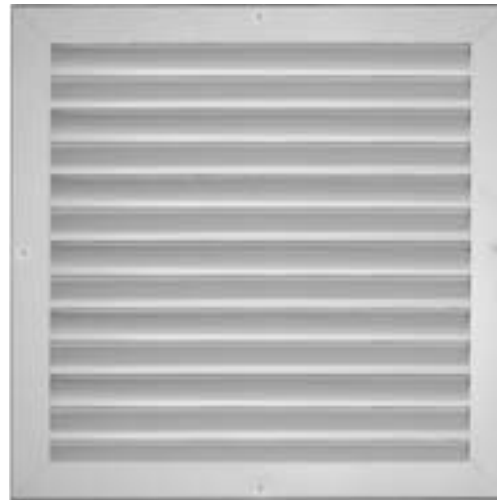

FDLS Inverted Split Y Non-Vision Grille

**DRDL**  
Double Inverted V Grille  
for Darkroom Applications

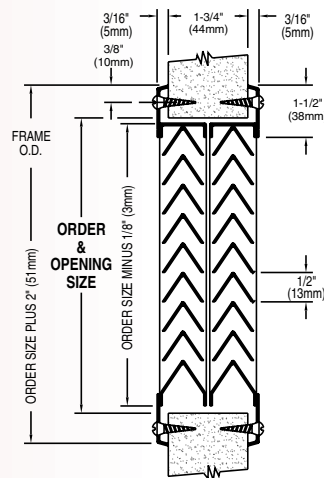

**DRDL (Half Pair)**  
Inverted V Grille  
for Darkroom Applications

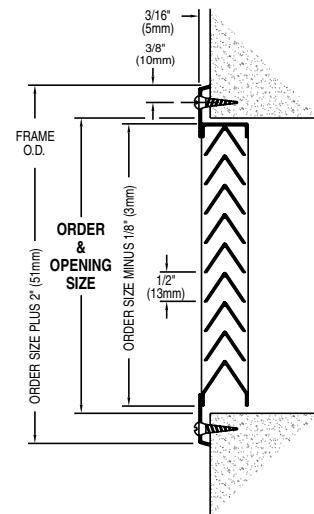

### CHDL-1F

Non-Vision Inverted V Grille  
with Frame One Side

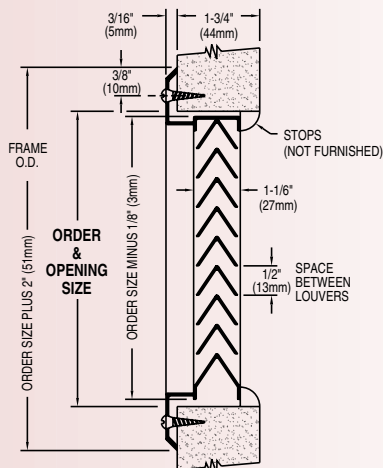

### FDLS

Inverted Split Y Non-Vision Grille

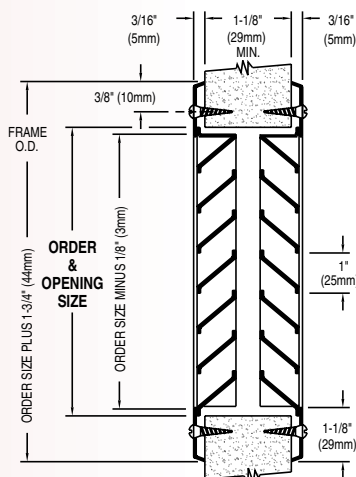

### FDLS (Half Pair)

Inverted Split Y Non-Vision Grille

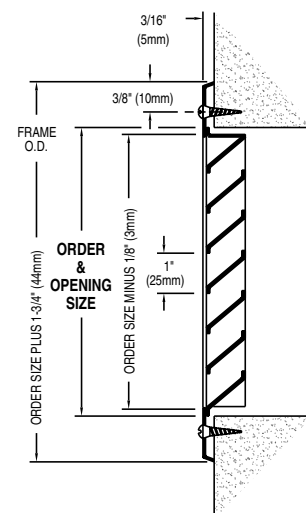

## PRODUCT FEATURES

### AFDL-T (Inverted Y, core only)

- 18 GA. Frame, 22 GA. Grille Blades
- For a 1 3/4" Door (1 3/8" is available)

### CHDL (Inverted V, core only)

- 22 GA. Grille Blades
- Installs with stops on both sides
- Ideal for use with Transoms or Wood Doors

## SPECIAL FEATURES

- Arctic White baked-on finish
- Custom Baked Enamel Colors (Color/Wood Stained Chip required for paint match)
- Security Screw Fasteners
- Mesh Screens
- #304, or #316 Stainless Steel #4 Finish (satin)
- Galvanized Sheet Metal
- Aluminum #5052 (mill finish or anodized)

**NOTE:** For Exterior use, High Humidity or Salt Air Application, product must be Galvanized or Stainless Steel.



AFDL-T Non-Vision Inverted Y Grille, Core Only

**AFDL-T**  
Non-Vision Inverted Y Grille, Core Only

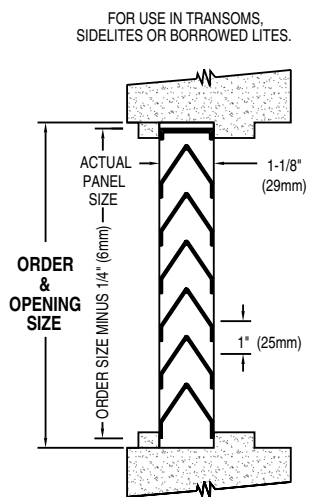

**CHDL**  
Non-Vision Inverted V Grille, Core Only

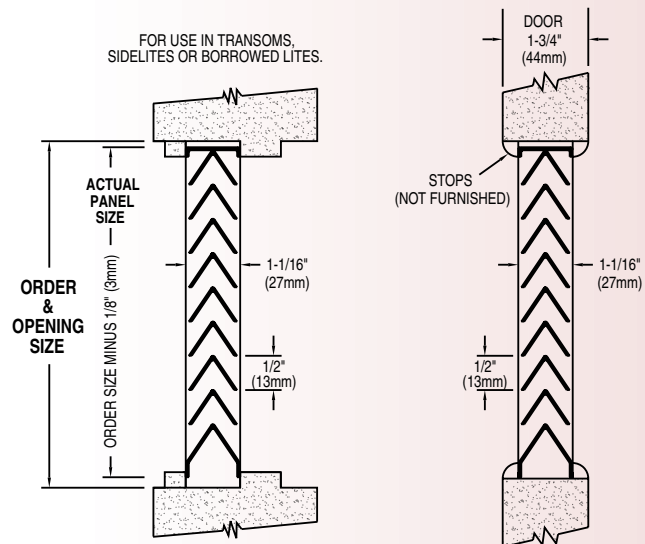

## PRODUCT FEATURES

### AFDL (Inverted Y)

- Our top seller fastens the auxiliary frame to the grille core, thru the cutout in the door, eliminating the need to drill holes in the door.
- 18 GA. Frame, 22 GA. Grille Blades
- For a 1 3/4" Door (1 3/8" is available)

### CHDL-2F (Inverted V, frame both sides)

- 18 GA. Frame, 22 GA. Grille Blades
- Installs by means of screwing directly into the door
- Vision proof

### FLDL-U.L. (Fire Rated with U.L. label/BS 476.22)

- Fire rated door grille up to 90 min., Max. size 24 x 24
- 18 GA. Frame and Grille Blades
- Self Attaching installation (see AFDL)
- Stainless steel operating springs assure proper action when the 160° fusible link releases the closing mechanism

### ADL (Adjustable Z Blade)

- 18 GA. Frame and Grille Blades
- Self Attaching installation (see AFDL)
- For use in applications when an adjustable grille is required, but need not be fire rated

## SPECIAL FEATURES

- Arctic White baked-on finish
- Custom Baked Enamel Colors (Color/Wood Stained Chip required for paint match)
- Security Screw Fasteners
- Mesh Screens
- #304, or #316 Stainless Steel #4 Finish (satin)
- Galvanized Sheet Metal
- Aluminum #5052 (mill finish or anodized)

**NOTE:** For Exterior use, High Humidity or Salt Air Application, product must be Galvanized or Stainless Steel.



FLDL-UL Fire Rated Fusible Link Door Grille

