

APPLICATION

- Battens are perimeter trim strips applied to outer edges of surface installed diffusers
- Provide a neat, finished appearance and mask the ceiling opening edge
- Single diffusers or a built-up array of diffusers
- Standard on all hard ceiling (surface) applications
- Arrangement **MUST** be specified

FEATURES

- Factory welded to the outer edge(s) of the removable face (outside edges and corners)
- Each diffuser batten is separate from the next, allowing individual face removal for balancing, servicing, and cleaning.
- Outside corner battens are mitered
- Slip-on style battens are field cut and installed for inside corner arrangements for built-up arrays.
- Batten arrangements are identified by two letters
- Same material as diffuser material
- Used on surface installed models MV-1, MV-2, MV-HEP, HCR, HCRF

Model HCR-PA Shown

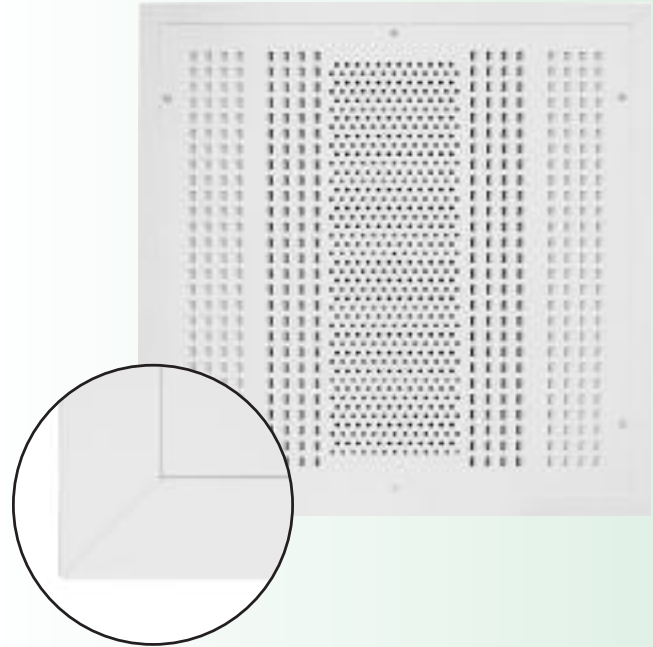

FACTORY ATTACHED BATTENS

Batten arrangements shown are plan / reflected ceiling views

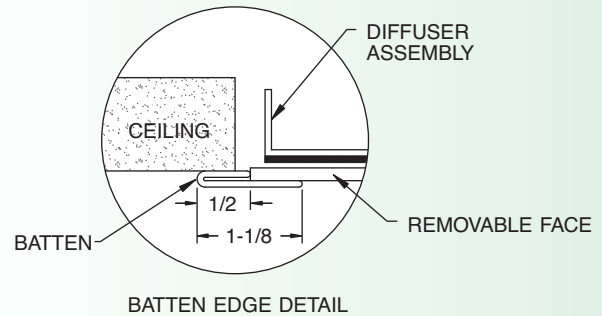
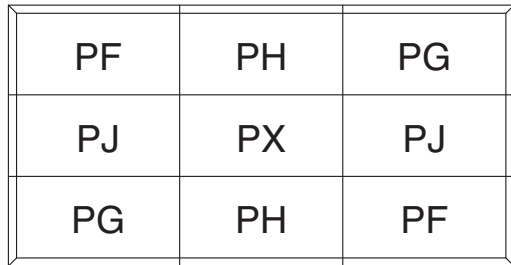
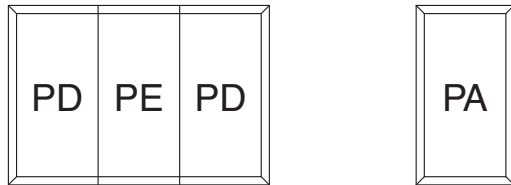

Use for HCR-90° patterns

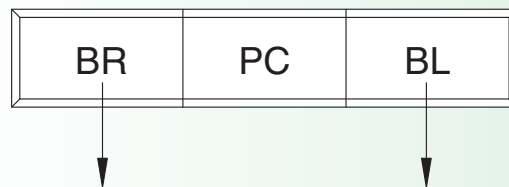

FEATURES

- Slip-on battens are field cut to final, installed length. Factory provides long lengths for this purpose.

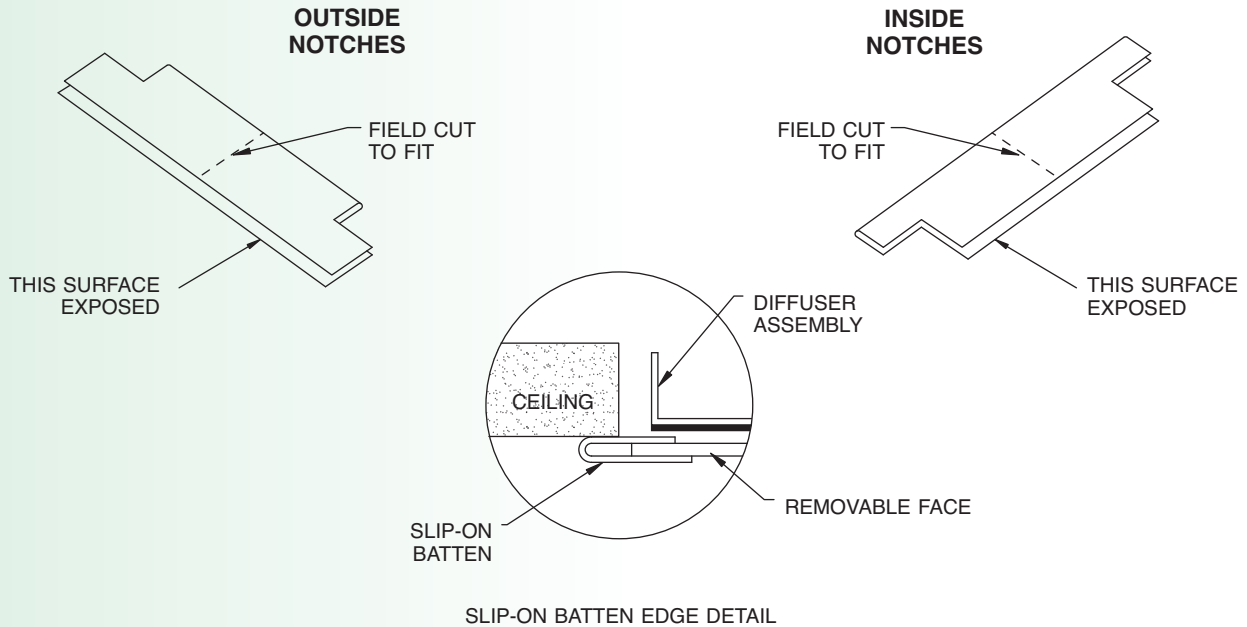

TYPICAL ARRANGEMENT REQUIRING SLIP-ON BATTENS

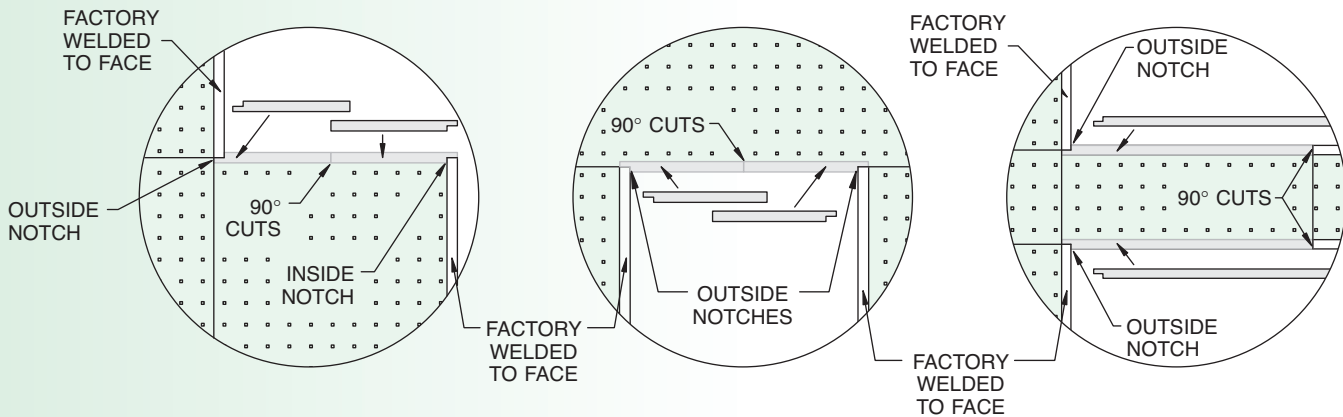

Note: Slip-on battens are field cut to final, installed length. Factory provides long lengths for this purpose.