

# SUBMITTAL SHEET

www.anemostat-hvac.com

## PRODUCT FEATURES

- Double deflection supply grille / register
- Removable, reversible core
- Blades are parallel to width dimension
- Concealed fastening thru neck of grille
- Maximum core height is 18". Multiple cores used in grille heights over 18".
- 48" x 48" maximum single piece construction. Multiple sections requiring field assembly over 48".

## CONSTRUCTION DETAILS

**Materials:** Extruded Aluminum

**Finish:** Arctic White baked on finish (std)

- Silhouette Finish
- Anemostat Color # \_\_\_\_\_
- Custom Color Match \_\_\_\_\_

## MODELS:

- R2** Supply Grille
- R20** Supply register includes factory attached:
  - OB1-ST** Steel opposed blade volume damper
  - OB1-AL** Aluminum opposed blade volume damper

## OPTIONS:

- Factory applied gasket material to frame

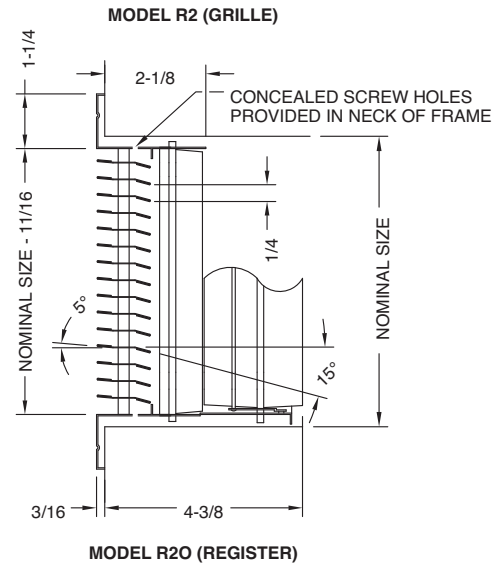
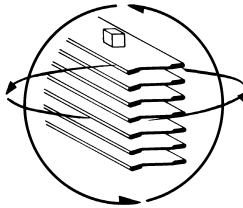
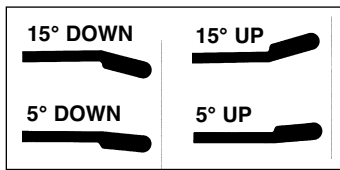

All dimensions are in inches.

JOB NAME:

SUBMITTED BY: