

Model **SLAD-150**
STRAIGHT LINE
ADJUSTABLE DIFFUSER
15/16" TEGULAR CEILING SYSTEMS
3/4" SLOT WIDTH / 1 TO 4 SLOTS

PRODUCT FEATURES

- Designed for use with 15/16" Narrow Slot or Tegular suspended grid systems
- Standard lengths = 24", 30", 36", 48", 60", 72" (custom lengths available)
- 1/2" Slot Width, 2 thru 4 slots (2 slot configuration shown)
- Includes plenum mounting yokes

CONSTRUCTION DETAILS

- Extruded aluminum, adjustable linear slot diffuser
- Finish:**
 - Arctic White Border and Center Tees, Black Volume / Pattern Controllers
 - Optional Anemostat Color
 - Custom Color Match

MODELS

- Supply Diffusers**
- SLAD-T-150** 15/16" Tegular Ceiling
- Returns (No Volume / Pattern Controllers)**
- SLAR-T-150** 15/16" Tegular Ceiling

# OF SLOTS	A	B	Cross Section Grid ϕ
1	3-3/16	3-5/16	4-3/16
2	6-3/16	6-5/16	7-3/16
3	9-3/16	9-5/16	10-3/16
4	12-3/16	12-5/16	13-3/16

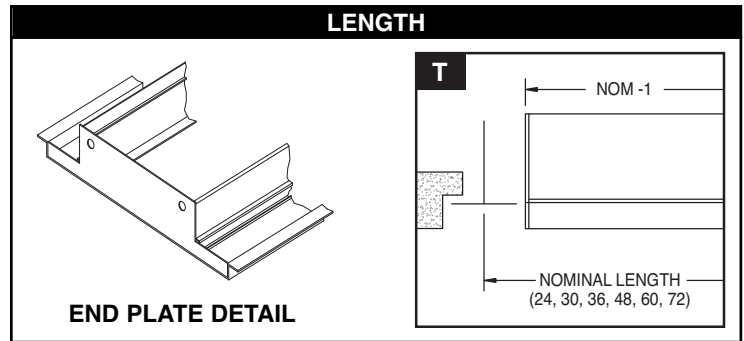

SUPPLY / 2 SLOT CROSS SECTION SHOWN

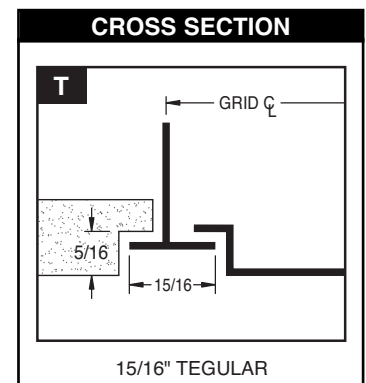
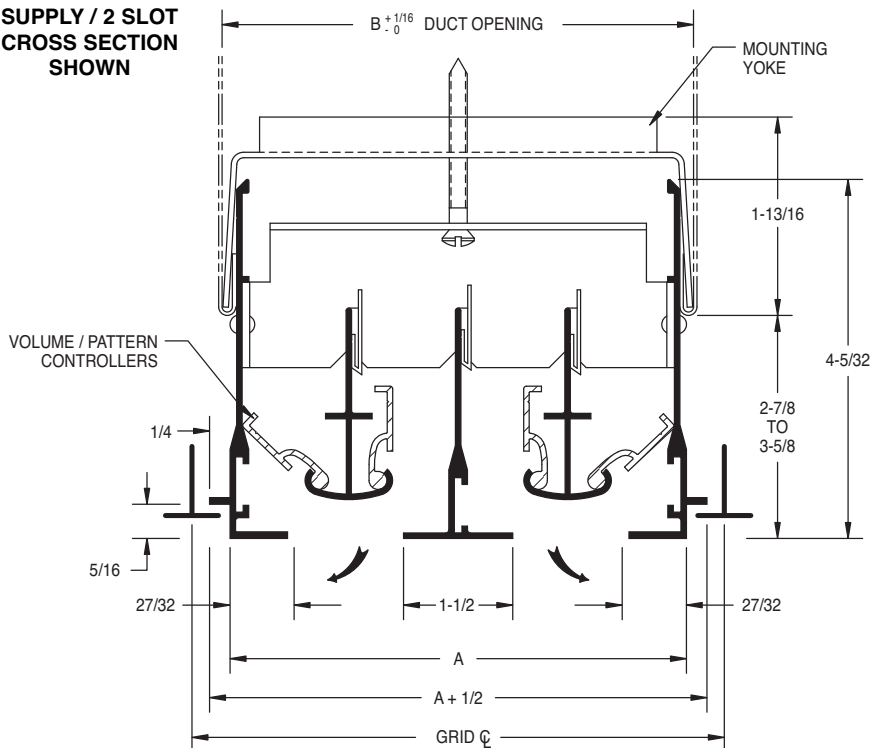

All dimensions are in inches.

JOB NAME:

SUBMITTED BY: