

SUBMITTAL SHEET

www.anemostat-hvac.com

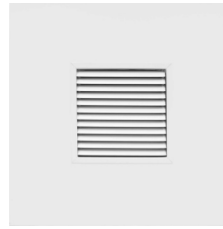

Model **30-T9**
FIXED BLADE
RETURN GRILLE

3/4" BLADE SPACING

9/16" TEGULAR DROP FACE
WITH EXTENSION PANEL

PRODUCT FEATURES

- Fixed Louver Return
- Registers include a factory attached, steel opposed blade volume control damper

CONSTRUCTION DETAILS

Material:

- Steel Construction
- All Aluminum Construction

Finish:

- Arctic White (std)
- Custom Color (opt)

Models

- 30-0-T9** 0° Deflection
- 30-45-T9** 45° Deflection

Extension Panel Size

- A** 06" x 30" Module
- B** 06" x 48" Module
- 11** 12" x 12" Module
- 12** 12" x 24" Module
- 22** 24" x 24" Module
- 24** 24" x 48" Module
- 30** 30" x 30" Module

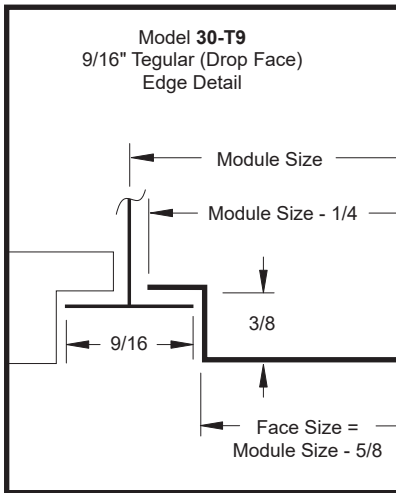

GRID / MODULE SIZE	MAX NECK SIZE
12 x 12	10 x 10
12 x 24	10 x 22
24 x 24	22 x 22
24 x 48	22 x 46
48 x 48	46 x 46

NOTE: Louvers are parallel to longer neck dimension as standard. Other Module sizes available.

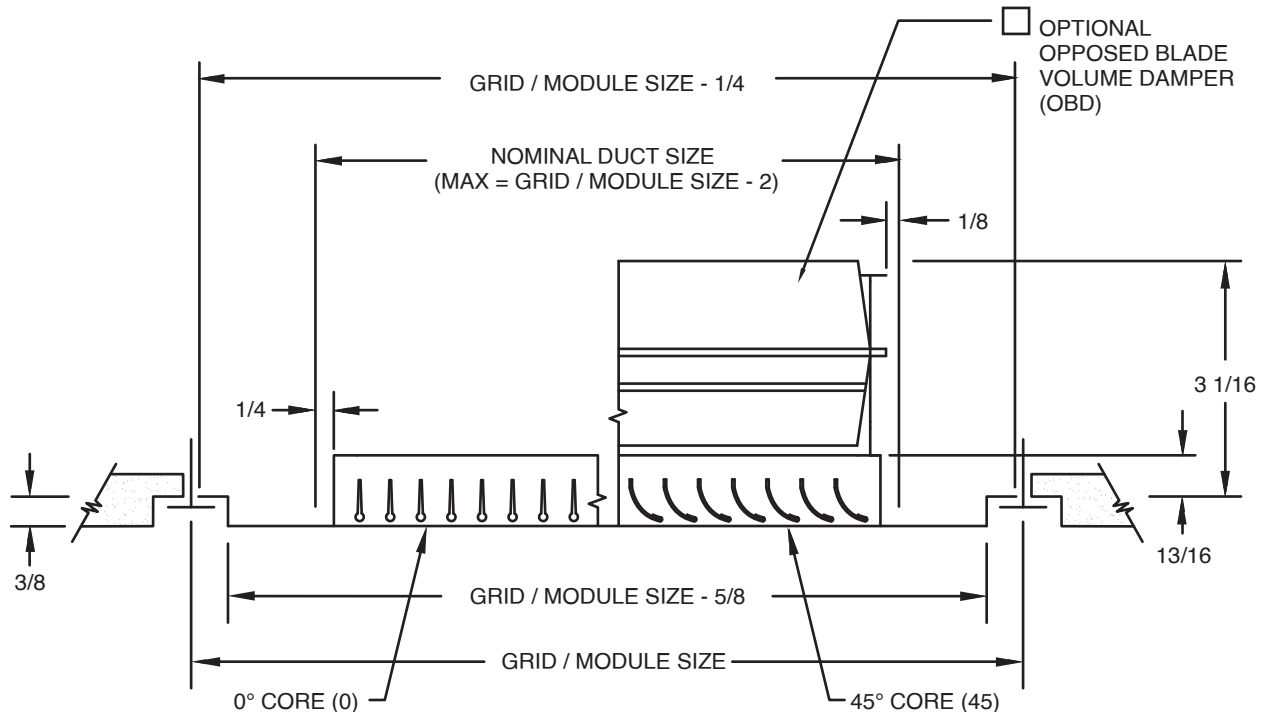

All dimensions are in inches.

JOB NAME:

SUBMITTED BY: