



Anemostat®

AIR DISTRIBUTION

SUBMITTAL SHEET

www.anemostat-hvac.com

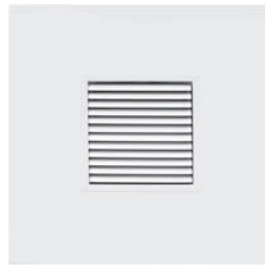

Model **E30-T**

**ENHANCED CAPACITY
FIXED BLADE RETURN**

3/4" SPACING
LAY-IN TEGULAR (15/16")
WITH EXTENSION PANEL
40° DEFLECTION

PRODUCT FEATURES

- Fixed Louver Return
- Registers include a factory attached, opposed blade volume control damper (steel, alum, or stn steel)

CONSTRUCTION DETAILS

Material:

- STEEL (ST)
- ALUMINUM (AL)
- 304 STN STEEL (04)

Finish:

- ARTIC WHITE (STD)
- SATIN POLISH (STN STEEL ONLY)
- CUSTOM COLOR _____

Extension Panels Available

- A 06" x 30" Module
- B 06" x 48" Module
- 11 12" x 12" Module
- 12 12" x 24" Module
- 22 24" x 24" Module
- 24 24" x 48" Module
- 30 30" x 30" Module

Accessories

- O B-1-ST Opposed Blade Damper (Steel)
- O B-1-AL Opposed Blade Damper (Aluminum)
- O B-1-04 Opposed Blade Damper (Stn Steel)

OPTIONAL OPPOSED BLADE VOLUME CONTROL DAMPER (MODEL OB-1)

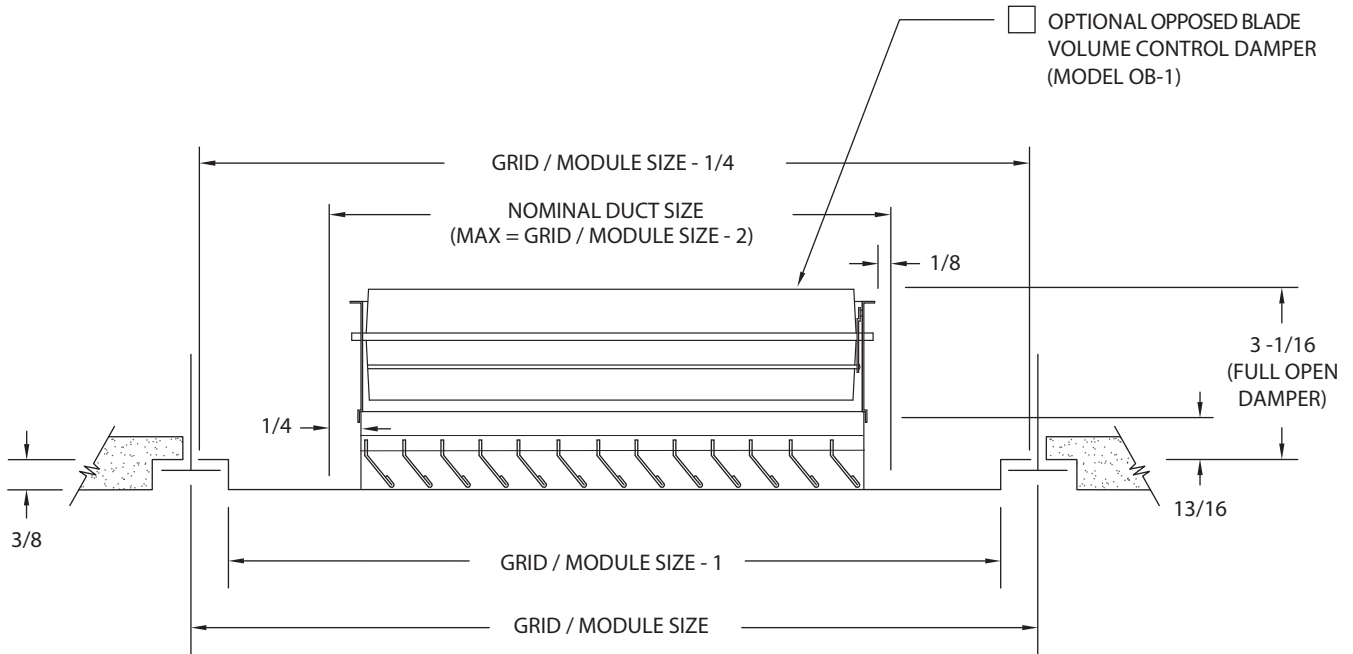

GRID / MODULE SIZE	MAX NECK SIZE
12 x 12	10 x 10
12 x 24	10 x 22
24 x 24	22 x 22
24 x 48	22 x 46
48 x 48	46 x 46

NOTE: Louvers are parallel to longer neck dimension as standard.

All dimensions are in inches.

JOB NAME:

SUBMITTED BY: