

Anemostat® SUBMITTAL

1220 Watson Center Road • Carson, CA 90745-4206
(310) 835-7500 • FAX (310) 835-0448
air@anemostat.com • www.anemostat-hvac.com

Model **MV-1** LAMINAR FLOW PANELS SINGLE CHAMBER

DIFFUSERS

PRODUCT FEATURES

- Single chamber design provides vertical projection of air over critical work areas.
- Perforated face is 13% open, and removable via 1/4 turn fasteners for cleaning
- Face is hinged and swings down 90° for easy cleaning. Safety cables prevent face from accidentally swinging down.
- Balancing damper adjustable from panel face through hole with removable plug
- Closed cell gasket prevents leakage around face

MATERIAL AND FINISH

Distribution Panel:

- Steel with White Baked Epoxy
- Aluminum with White Baked Epoxy
- 304 Stainless Steel, #4 Polish
- 304 Stainless Steel with White Baked Epoxy

Plenum:

- Steel with White Baked Epoxy
- Aluminum with White Baked Epoxy
- 304 Stainless Steel, 2B Mill Finish
- 304 Stainless Steel with White Baked Epoxy

MODELS

- MV-1T** Lay-In T-Bar
- MV-1P** Surface Mounted

Model MV-1T
Lay-In T-Bar

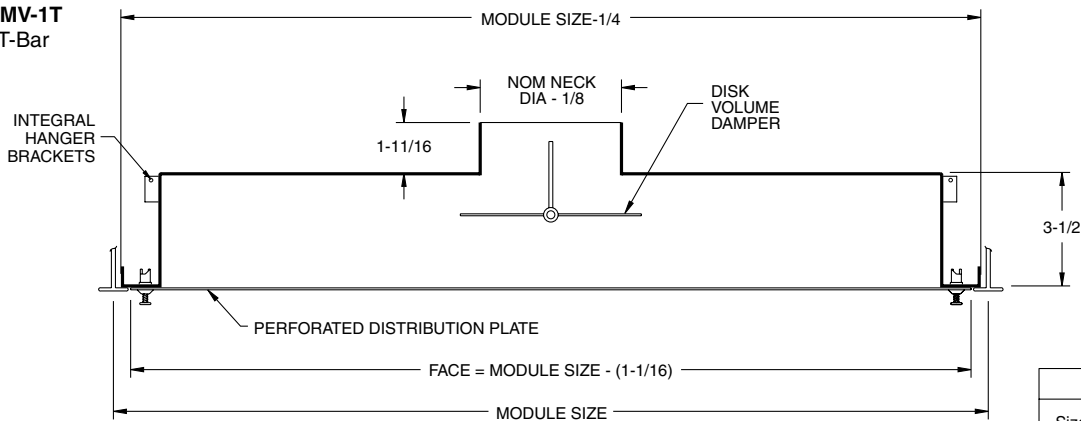

Model MV-1P
Surface Mounted

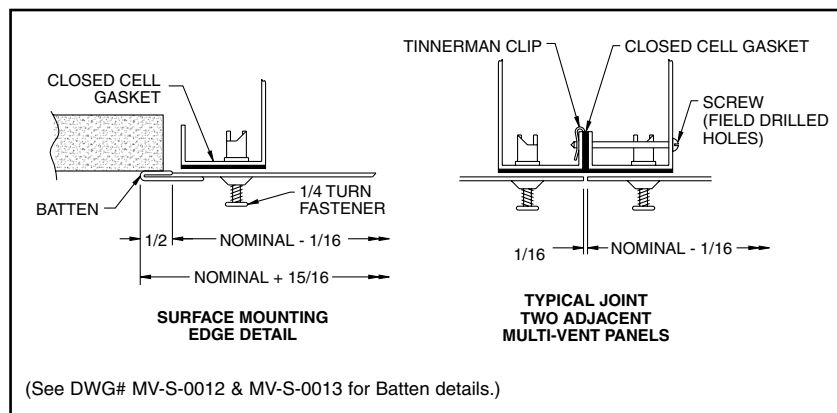

PANEL DIMENSIONS		
Size	Nom. Size	Max Neck Size
082	8 x 24	5" DIA
083	8 x 36	
084	8 x 48	
085	8 x 60	
086	8 x 72	
122	12 x 24	9" DIA
123	12 x 36	
124	12 x 48	
125	12 x 60	
126	12 x 72	
242	24 x 24	18" DIA
243	24 x 36	
244	24 x 48	
245	24 x 60	
246	24 x 72	
363	36 x 36	18" DIA
364	36 x 48	
365	36 x 60	
366	36 x 72	

All dimensions are in inches.

JOB NAME:

SUBMITTED BY: