

# Anemostat®

## SUBMITTAL

1220 Watson Center Road • Carson, CA 90745-4206  
 (310) 835-7500 • FAX (310) 835-0448  
 air@anemostat.com • www.anemostat-hvac.com

Model **MV-HEP**  
**LAMINAR FLOW PANELS**  
**DUAL CHAMBER**  
**WITH HEPA FILTER**  
**END INLET**

### DIFFUSERS

#### PRODUCT FEATURES

- Multi-Vent -filter interface includes knife edge into filter gel seals for zero leak performance
- Pressure port to measure HEPA filter pressure drop
- Perforated face is 13% open, and removable via 1/4 turn fasteners for cleaning
- Face is hinged and swings down 90° for easy cleaning. Safety cables prevent face from accidentally swinging down.
- Balancing damper adjustable through hole with removable plug
- Closed cell gasket prevents leakage around face

#### MATERIAL AND FINISH

##### Distribution Panel:

- Steel with White Baked Epoxy
- Aluminum with White Baked Epoxy
- 304 Stainless Steel, #4 Polish
- 304 Stainless Steel with White Baked Epoxy

##### Dual Chamber Plenum:

- Steel with White Baked Epoxy
- Aluminum with White Baked Epoxy
- 304 Stainless Steel, 2B Mill Finish
- 304 Stainless Steel with White Baked Epoxy

#### MODELS

- MV-HEP-T Lay-In T-Bar (End Inlet)
- MV-HEP-P Surface Mounted (End Inlet)

#### OPTIONS

- Light Alert Filter Monitoring System
- ACS Aerosol Challenge System
- MVH-P Air Distribution Panel
- MVH-V Air Distribution Baskets

PANEL DIMENSIONS	
Module Size	Max Neck Size
12 x 48	8ø
24 x 24	8ø
24 x 48	8ø

Model MV-HEP-T  
 Lay-In T-Bar  
 (End Inlet)

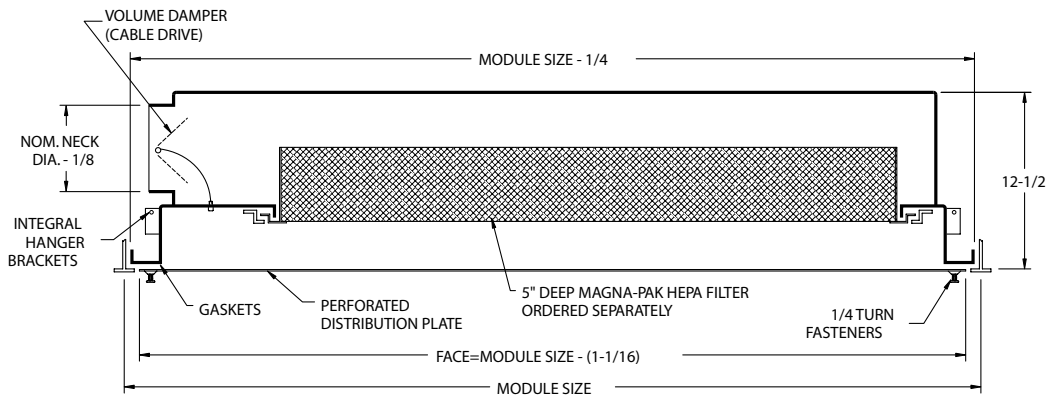

Model MV-HEP-P  
 Surface Mounted

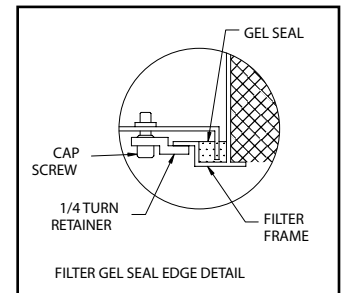
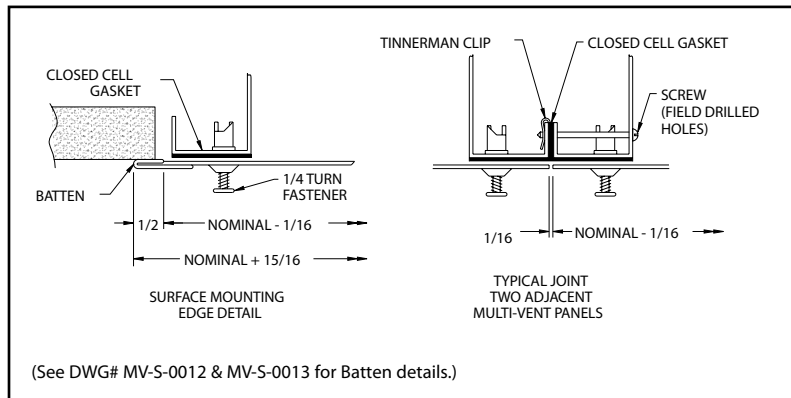

All dimensions are in inches.

JOB NAME:

SUBMITTED BY: