



Anemostat®
AIR DISTRIBUTION

MODEL **SL33**

EXTRUDED ALUMINUM LOUVERS
4" DEEP

CHEVRON-SIGHTPROOF-STANDARD CHANNEL TYPE

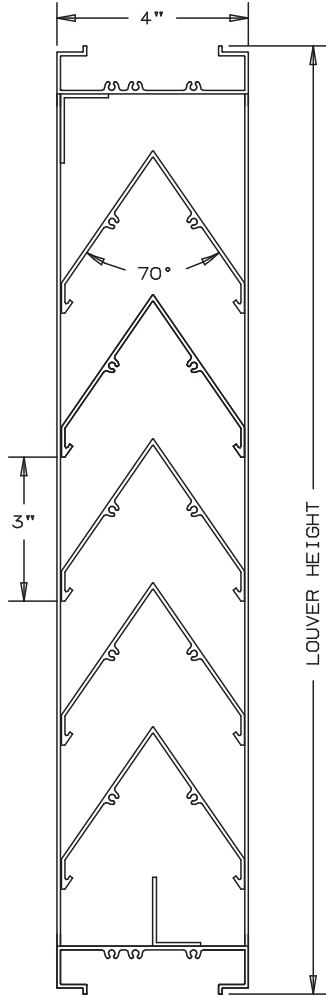

NOT TO SCALE

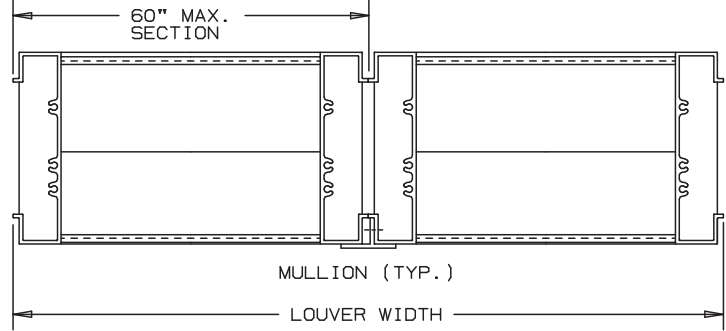

SPECIFICATIONS

MATERIAL: EXTRUDED ALUMINUM 6063-T6/T52 ALLOY
.081" THK.

FACE OF LOUVER: ALL SURFACES ARE FLUSH, WITH JAMBS
CONTAINED WITHIN THE HEAD AND SILL.

SCREEN: (WHEN INDICATED)

- BIRD SCREEN - 1/2" FLATTENED ALUMINUM, .051" THK.
- OR - 1/2" SQ. MESH INTERMEDIATE DOUBLE-CRIMPED ALUMINUM WIRE, .063" DIA.
- OR - 18/16 MESH, .011" DIA. ALUMINUM WIRE INSECT SCREEN.

FINISH: _____

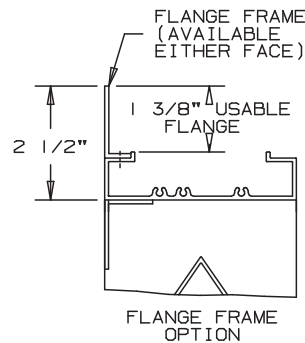

NOMINAL DEDUCTIONS WILL BE MADE TO OPENING SIZES GIVEN.

ITEM	QTY.	WIDTH	HEIGHT	WIDTH	HEIGHT	MULL	TYPE	LOC
		OPENING SIZE		LOUVER SIZE				



Anemostat Air Distribution 1220 E. Watson Center Road Carson, CA 90745 310-835-7500 • air@anemostat.com www.anemostat-hvac.com AGENT: _____	ARCH./ENG. :
	CONTR. :
	PROJECT :
	EDR: ECN: JOB:
	DATE: DWN. : DWG. :

MODEL SL33

CHEVRON BLADE

EXTRUDED ALUMINUM - STATIONARY

PERFORMANCE DATA

RATINGS DO NOT INCLUDE THE EFFECT OF BIRDSCREEN.

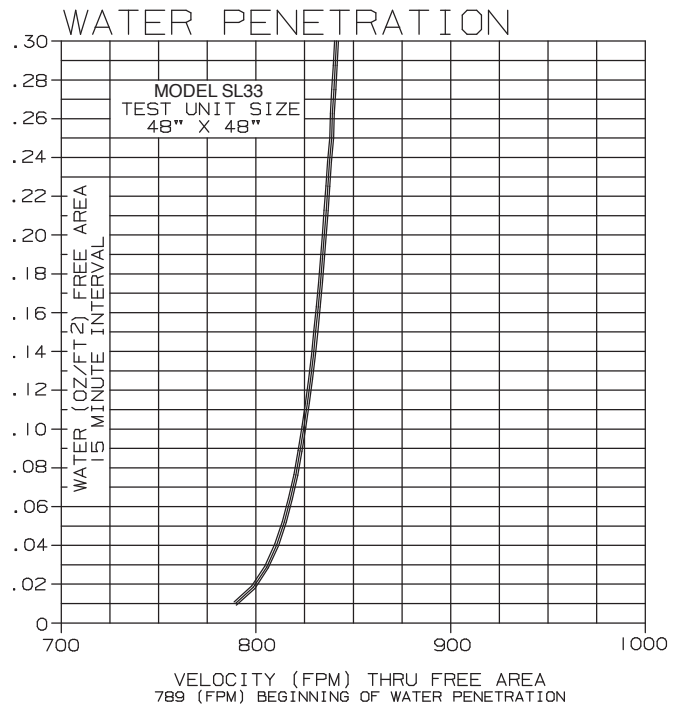
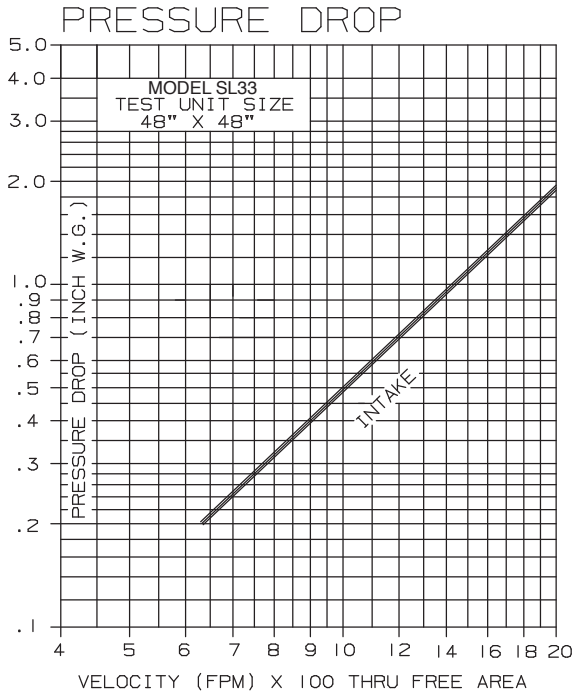

FREE AREA

	FREE AREA (SQ. FT.)								
	WIDTH								
	12"	18"	24"	30"	36"	42"	48"	54"	60"
12"	.27	.40	.53	.67	.80	.93	1.07	1.20	1.33
24"	.70	1.04	1.39	1.74	2.09	2.43	2.78	3.13	3.48
36"	1.13	1.69	2.25	2.81	3.38	3.94	4.50	5.06	5.63
48"	1.55	2.33	3.11	3.89	4.66	5.44	6.22	6.99	7.77
60"	1.98	2.98	3.97	4.96	5.95	6.94	7.93	8.93	9.92
72"	2.41	3.62	4.83	6.03	7.24	8.45	9.65	10.86	12.07
84"	2.84	4.26	5.68	7.11	8.53	9.95	11.37	12.79	14.21
96"	3.27	4.91	6.54	8.18	9.82	11.45	13.09	14.72	16.36