

SUBMITTAL SHEET

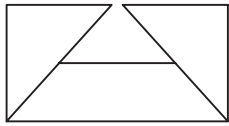

®

from: **ANEMOSTAT**®

CARSON CA
310-835-7500

MODEL
CHDL-2F
INVERTED 'V' LOUVER
NON VISION

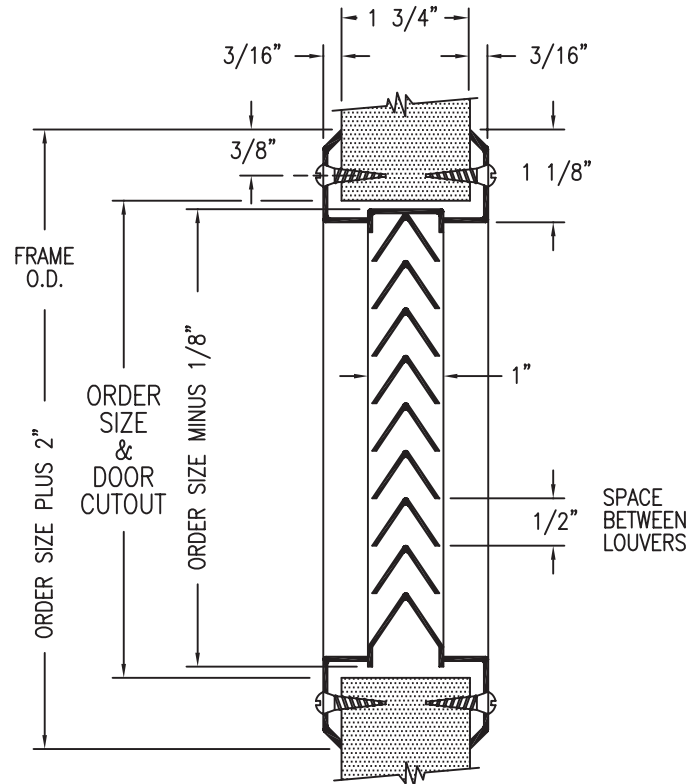
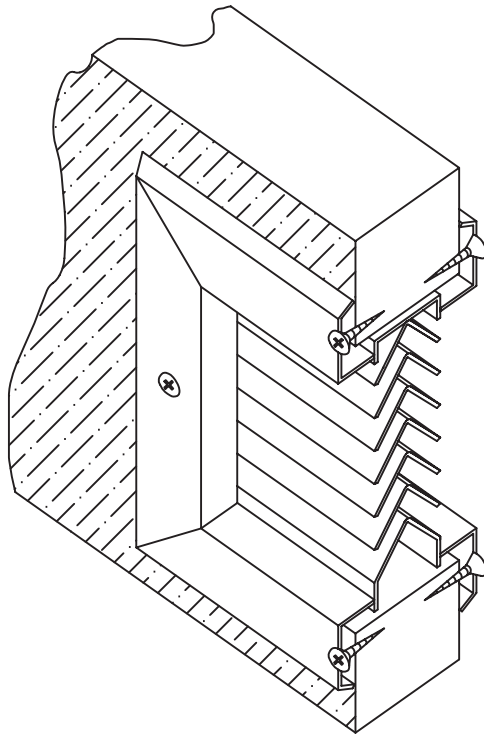

All Dimensions $\pm 1/32$

STANDARD PRODUCT FEATURES

- MATERIAL: 18 GA. Cold Rolled Steel – Frame, 22 GA. Cold Rolled Steel – Louver Blades.
- FINISH: Arctic White, Baked-On
- INSTALLATION: Fastens to door by means of #8x3/4" sheet metal or wood screws, directly into the door thru countersunk mounting holes.
- DOOR THICKNESS: For 1 3/4" Door (1 3/8" is available)
- AESTHETICS: Tight mitered corners, no visible welds make for a clean, sharp look.
- USES: Where 1/2" louver spacing is preferred.
- FREE AIR FLOW: 60% Free Area.

OPTIONAL FEATURES

- MATERIAL: #304 Stainless Steel, #4 Finish Satin), Galvanized (Sheet Hot Dipped or Zinc Plated), Mill Finish Aluminum (#5052 Alloy)
- FINISH: Special order Baked Enamel Colors (as per sample chip, supplied by customer).
- FASTENERS: Special Security Screw Fasteners, See Page 10, this section.
- SPECIALS: Fractional sizes (frame dimension is increased to accommodate odd size). Mesh insect screens, loose or attached. (Galvanized, Aluminum, Charcoal Aluminum, Stainless Steel.)
- DOOR THICKNESS: For 1 3/8" is available by special order.

FIRE RATINGS

- CHDL-2F is not fire rated.

- NOTE: For Exterior use, High Humidity or Salt Air application, product must be Galvanized or Stainless Steel.

All Dimensions are in Inches

JOB NAME:	SUBMITTED BY:
LOCATION:	
ARCHITECT:	
ENGINEER:	DWG # LOV-0007
CONTRACTOR:	DATE 6-15-05 REV C