

AIR FLOW SOLUTIONS

Installation, Operation, & Maintenance

MODEL FFU - 2
FAN HEPA FILTER UNIT

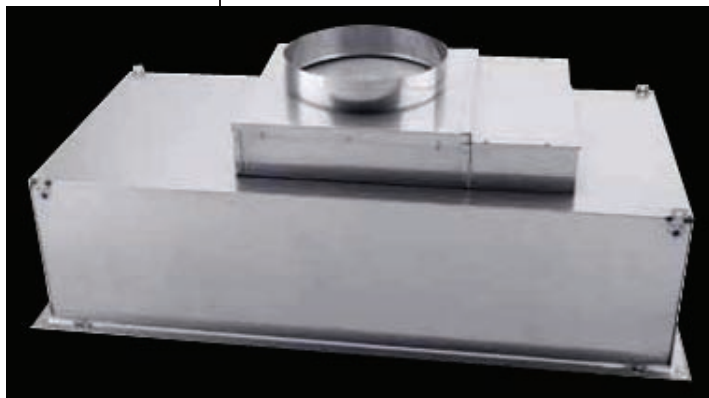

Table of Contents

Model FFU-2 Part Numbers	3
Critical Operating Condition / Replacement Parts	4
Electrical Warnings	5
Installation Checklist	6
Installation	7
HEPA Filter / Removal & Replacement	8
Motor / Removal & Installation (Plenum Side Removal)	9
Motor / Removal & Installation (Room Side Removable Option)	10
Electrical Component Access (Plenum Side Access)	11
Electrical Component Access (Room Side Access Option)	12
Ducted Applications / VAV Air Terminals	13
Electronic Controller Display & Adjustments	14
Aerosol Challenge System (Optional)	15
Controls for the FFU-2 Fan Filter Unit	16
Networking	17
EC Motor Controller Data	18
Controller Address Settings for Networking / Example	19
Controller Input Sensors / Jumper Positions	20
Pressure Transducer 0 - 10vdc Typical Wiring (Optional)	21
Pressure Transducer 4-20mA Typical Wiring (Optional)	22
Power Switch / Resettable Fuse	23
Wiring for FFU-2 (Plenum Access)	24
Wiring for FFU-2 (Optional Motor / Electronics Room Side Accessible)	25
Controller Address DIP Switch settings / Example	26
Pre-Filter Cleaning	27
Testing / Troubleshooting	28

Model FFU-2 FAN HEPA Filter Modules - Part Numbers

Typ String: FFU-2 / U / R / 244 / G / C / 12 / B / 04 / 4P / 04 / ML

Field	Field Description	Input Code	Description
1	Model	FFU-2	Fan Filter Hepa Unit - 2" HEPA Filter
2	Installation	U	Universal for Surface or 1" T-Bar Applications
3	Filter Replacement Type	R	Room Side Replaceable Filter
		B	Bench Replacement (Removal from Ceiling Req'd)
4	Nominal Unit Size	242	24" x 24"
		243	24" x 36"
		244	24" x 48"
		245	24" x 60"
5	Filter Seal	G	Gel (Room Replaceable Only)
6	Filter Type	C	99.99% @ .3u (HEPA Filter - Ships Separate)
		E	99.999% @ .12u (ULPA Filter - Ships Separate)
7	Inlet/Duct Collar Size (TOP)	-	None (Ceiling Supply)
		10	10" Ø
		10VS	10" OVAL - SIDE LOCATION
		12VS	12" OVAL - SIDE LOCATION
		12	12" Ø
		14	14" Ø
8	Motor Voltage, 1Φ	A	115 vac (ECM - Speed Controller Attached to Unit)
		B	208/230/240 vac (ECM - Speed Controller Attached to Unit)
		C	277 vac (ECM - Speed Controller Attached to Unit)
9	Perforated Face Material	04	304 Stainless Steel
		16	316 Stainless Steel
		AL	Aluminum
10	Face Finish	4P	Satin Polished Finish
		WH	White
11	Fan/Filter Housing Material	04	304 Stainless Steel
		16	316 Stainless Steel
12	Fan/Filter Housing Finish	ML	Mill Finish
13	Optional Features	BI	Backward Inclined Wheel
		F1	Insulation, External (Top Only)
		LA	Light Alert LED Filter Loading Indicator
		MC	Manifold for PAO Challenge from Face
		PD	Pressure Xducer (Filter Pressure Drop) via Network
		PF	Expanded Aluminum Pre-Filter
		RC	Room side removable Motor/Blower Assembly, and Controls
		RM	Room side removable Motor/Blower Assembly
		WS	Wall Speed Switch (Rotary Knob)
		99	Special Construction - See Details

Critical Operation Conditions of the Fan Filter Unit

- DO NOT TOUCH the HEPA filter media. Damage to filter media may void the filter warranty. The screen is to protect against accidental contact with the filter. Never place objects on the filter. Always transport or lift the filter by its frame.
- Prior to powering the unit, verify that it is wired to the correct power supply. The rating plate label located on the electrical box shows the electrical data.
- For replacement parts refer to the model number and serial number on the rating plate label located on the electrical box.

Replacement Part numbers:

FPH-RP11 FPH 48 x 24 HEPA filter	FPH-RP40 FPH Face mounted airflow display board
FPH-RP12 FPH 16 x 16 x 3/8 expanded aluminum pre-filter	FPH-RP41 FPH Multi-input control board
FPH-RP13 FPH 24 x 24 HEPA filter	
FPH-RP14 FPH 14 x 14 x 3/8 expanded aluminum pre-filter	
FPH-RP16 FPH 36 x 24 HEPA filter	
FPH-RP21 FPH Programmable variable speed motor (120, 208/240VAC)	
FPH-RP22 FPH Programmable variable speed motor (277VAC)	
FPH-RP31 FPH Visual control circuit board	
FPH-RP32 FPH 0-10VDC control circuit board	
FPH-RP33 FPH Network control circuit board	
FPH-RP34 FPH Fan verification kit	
FPH-RP35 FPH LED filter indicator Kit	
FPH-RP36 FPH 120/24VAC transformer	
FPH-RP37 FPH 208/240/24VAC transformer	
FPH-RP38 FPH 277/24VAC transformer	
FPH-RP39 FPH Network power control circuit board	

Read Completely and Save These Instructions

WARNING - TO REDUCE THE RISK OF FIRE, ELECTRIC SHOCK, OR INJURY TO PERSONS, ALLOW ONLY QUALIFIED TECHNICIANS TO INSTALL AND SERVICE THE UNIT. ALL PERSONS SHOULD OBSERVE THE FOLLOWING:

- a) Use this unit only in a manner intended by the manufacturer.
If you have questions, contact the manufacturer.
 - b) Before servicing or cleaning unit, switch power off at the service panel and lock-out the service in accordance with OSHA (LOTO) practices and procedures to prevent power from being accidentally switched on avoiding accidental electric shock and injury. When the service disconnecting means cannot be locked, securely fasten a prominent warning device, such as a tag, to the service panel.
- Installation work and electrical wiring must be completed by qualified personnel in accordance with all applicable codes and standards, to include fire-rated constructions.
 - When cutting or drilling into walls and ceilings, be careful not to damage electrical wiring and other hidden utilities.
 - If this unit is to be installed within close proximity to water, mark the unit in accordance with applicable codes and standards.
 - This unit is to be used only as intended by the manufacturer. If you have any questions regarding the use, installation, or operation of this unit, contact the manufacturer:

Installation Checklist

This is to provide a general overview of what steps should be taken to achieve a successful installation of the fan filter unit. These steps should be performed in the order listed. For more detail see applicable section in this instruction manual. Read the entire manual before beginning installation.

- Unbox and inspect the fan filter unit.
- If the unit is to be ducted, set upstream air device to produce 0.0" W.C. static pressure at the fan unit inlet. Use dampers if necessary if installing multiple fan units on the same duct line.
- Install the fan unit into the ceiling. Support its weight from structure above.
- Connect ductwork to fan unit (if applicable).
- Seal the fan filter unit to the ceiling using gasketing and caulking.
- Connect main power wiring.
- Connect control wiring (if applicable).
- Run the unit and/or upstream air device to flush out construction debris.
- Install the pre-filter (if applicable).
- Install the HEPA/ULPA filter.
- Turn unit on and adjust airflow to design CFM.
- Turn on the upstream airflow device.
- Leak test the fan unit and filter per local codes and building procedures.
- Install the perforated face screen.
- Verify airflow with a flow hood.

Installation

The terminal unit is fully assembled from the factory with the exception of the HEPA filter and lamps (as applicable) which is shipped in a separate box.

Step 1 -- Carefully remove the unit from the shipping carton and inspect for damage that may have occurred during shipping. If shipping damage is found, do NOT install. Call the Anemostat representative.

Step 2 -- Wipe down unit to remove shipping dust and debris.

Step 3 -- Raise unit into ceiling and lower onto gasketed opening. Gasket should be a closed-cell material approved for the environmental conditions. It is highly recommended to further support the unit from above using the tabs welded to the plenum.

Step 4 -- A qualified technician should connect the unit to the appropriate power supply per applicable codes and standards. Refer to the wiring diagrams included in these instructions. Note that Model FFU-2 can be ordered with the controls/electronics room-side accessible where the electrical box will be accessible from the room. Otherwise, the electrical box will be accessible from the plenum side.

NOTE: If the FFU-2 is installed in an area with no access above the ceiling, the main power switch must be turned on before installing the unit.

NOTE: An additional disconnect should be added by others per local codes and regulations.

NOTE: Supply voltage to FFU-2 units can be ordered for 120vac, 208/240vac, or 277vac power supply.

Step 5 -- Blow out / clean entire duct system leading to unit to remove construction debris. This is especially important for motor accessible units as they do not have a pre-filter. Wash pre-filter if applicable per "Cleaning the Fan Filter Unit "Pre-Filter" on page 7.

Step 6 -- Install the HEPA filter per the "Removal and Replacement of the HEPA Filter with Gel Seal" section.

NOTE: FOR DUCTED INSTALLATIONS, IT IS RECOMMENDED THAT PRIMARY AIR BALANCING TO ACHIEVE A 0.00" WC INLET STATIC PRESSURE BE DONE BEFORE FAN FILTER UNIT IS CONNECTED TO DUCT SYSTEM.

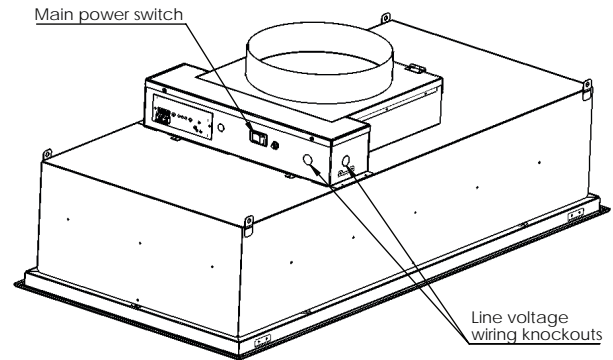

Removal and Replacement of the HEPA Filter with Gel Seal

WARNING!

Disconnect the unit from the electrical power source before attempting to service the unit.

WARNING!

The HEPA filter may be protected by an expanded metal screen.

The screen prevents accidental contact with the filter media.

It is not meant to allow handling of the filter by the media.

Handle the filter **ONLY** by the frame.

NOTE: The manufacturer recommends two people to remove and install the HEPA filter in the unit.

Step 1 -- Using a flat screwdriver, release the face frame by rotating the four (4) fasteners a 1/4-turn counter clock-wise.

Unhook the safety cables from the filter clips. Set the frame aside.

Step 2 -- Turn the unit off with the switch located on the unit (round, black button).

Step 3 -- Disconnect the unit at the power source or at the service panel in accordance with OSHA (LOTO) practices and procedures.

Step 4 -- **USE TWO PEOPLE TO SUPPORT THE FILTER** and rotate the swingarm filter clips off of the filter until clip is clear of the filter.

Step 4 ALT (if stud style filter clips) -- Using a 7/16" nut-driver, evenly loosen the nuts holding the filter retaining clips by working your way around the unit loosening the nuts a little at a time. To make installing the new filter easier, loosen the nuts until flush with the end of the threaded stud. **USE TWO PEOPLE TO SUPPORT THE FILTER** and rotate the filter clips toward the offset hole until clip is clear of the filter.

Step 5 -- Allow gravity to pull the filter away from the unit. If installing a new filter discard the filter in an appropriate manor.

Step 6 -- Unpack the new filter and inspect for shipping damage. If damage is found, do not install in unit; call the vendor for replacement arrangements.

Step 7 -- Using two people, raise the filter into place in between the filter guides (or threaded posts if stud style) assuring the seal edge is approximately in the center of the gel channel.

Step 8 -- While supporting the filter by its frame, rotate the filter clips so that the clips are supporting the frame and are at 90° to the frame. (ALT--Evenly tighten the nuts by working your way around the unit tightening the nuts a little at a time. Stop tightening when the aluminum filter frame contacts the stainless steel housing frame of the unit. **DO NOT OVER TIGHTEN**). Wait at least 30 minutes before performing any challenge testing to allow the gel to fully adhere to the unit.

Step 9 -- Inspect all gaskets and seals for integrity. Reconnect power and turn unit power on.

Step 10 -- Raise the face frame back into place, reattach the safety chains, and secure 1/4-turn fasteners.

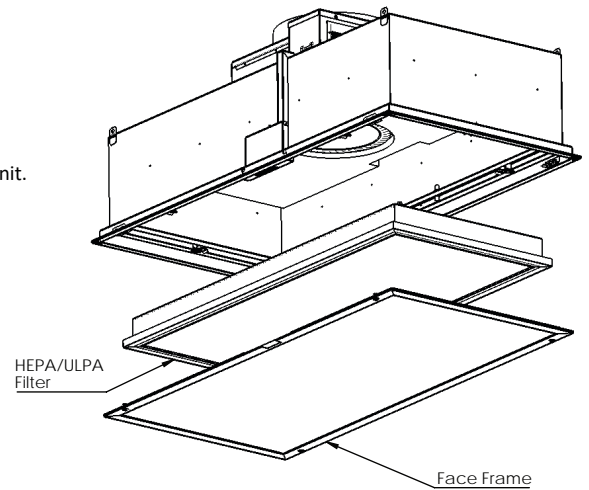

Removal and Installation of the Variable Speed Motor (Plenum Side)

WARNING!

Disconnect the unit from the electrical power source before attempting to service the unit.

Step 1 -- Turn the unit off with the switch located on the face of the unit.

Step 2 -- Disconnect the unit at the power source or at the service panel in accordance with OSHA (LOTO) practices and procedures.

Step 3 -- Remove the HEPA filter and the pre-filter and set aside. See sections 2 and 3 for instructions.

Step 4 -- Use a 1/8" drill bit and drill to remove the six (6) rivets located around the motor housing cover. Set cover aside. Clean out metal shavings and rivet parts from the unit. NOTE: if duct is attached to cover, be careful not to damage duct. Disconnect duct if necessary.

Step 5 -- Disconnect the 6-pin power cable and the 4-pin data cable from the motor.

Step 6 -- Using the 7/16" nut driver, remove the six nuts holding the motor.

Step 7 -- Lift the motor/fan/ring assembly out of the unit.

Step 8 -- Use a 5/32" hex driver to loosen set screw and slide fan off the motor shaft.

Step 9 -- Use a driver to remove the motor mount harness from the motor.

Step 10 -- Reverse above steps to reassemble the motor/fan/ring assembly into the unit. The fan collette should be even with the end of the motor shaft. Either rivets or sheet metal screws can used to secure the motor housing cover.

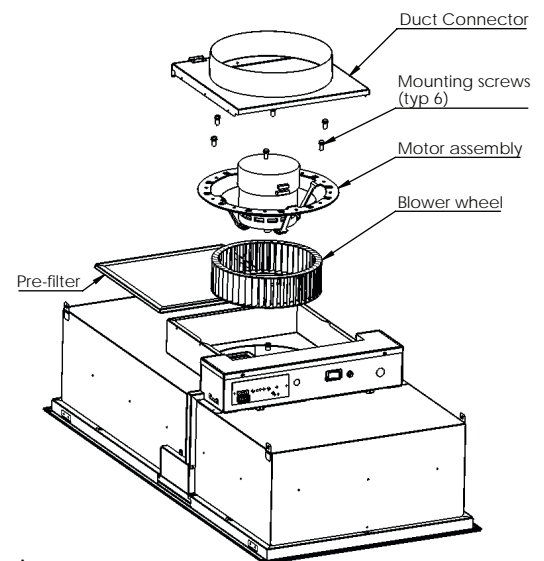

Removal and Installation of the Variable Speed Motor (Room-Side Removable Option)

WARNING!

Disconnect the unit from the electrical power source before attempting to service the unit.

Step 1 -- Using a flat screwdriver, release the face frame by rotating the four (4) fasteners a 1/4-turn counter clock-wise. Unhook the safety cables from the filter clips. Set frame aside.

Step 2 -- Turn the unit off with the switch located on the frame of the unit.

Step 3 -- Disconnect the unit at the power source or at the service panel in accordance with OSHA (LOTO) practices and procedures.

Step 4 -- Remove the HEPA filter and the pre-filter and set aside. See sections 2 and 3 for instructions.

Step 5 -- Using a flat screwdriver, release the mid panel by rotating the three (3) fasteners a 1/4-turn counter clock-wise. Allow panel to swing down to vertical and remove from unit. Set aside.

Step 6 -- Use a 5/32" hex driver to loosen set screw and slide fan off the motor shaft.

Step 7 -- Disconnect the 6-pin power cable and the 4-pin data cable from the motor.

Step 8 -- Using the 7/16" nut driver, remove the six (6) nuts holding the motor.

Step 9 -- Lower the motor/ring assembly out of the unit.

Step 10 -- Use a driver to remove the motor mount harness from the motor.

Step 11 -- Reverse above steps to reassemble the motor/fan/ring assembly into the unit. The fan collar should be even with the end of the motor shaft.

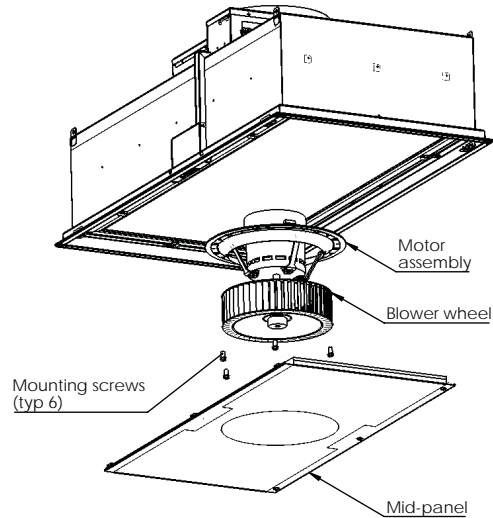

Access to Electrical Components (Plenum Side Access)

WARNING!

Disconnect the unit from the electrical power source before attempting to service the unit.

Step 1 -- Turn the unit off with the switch located on the electrical box.

Step 2 -- Disconnect the unit at the power source or at the service panel in accordance with OSHA (LOTO) practices and procedures.

Step 3 -- Use a 5/16" hex driver to remove screws holding electrical access panel. Swing panel up to release from the tabs.

Step 4 -- To remove transformer:

Step 4a -- Disconnect all wires from terminals. See wiring diagram for replacing wires.

Step 4b -- Using a 1/8" drill bit, drill out the two rivets. Clean debris.

Step 4c -- Use new 1/8" rivets or #6 screws to install replacement transformer.

Step 5 -- To remove control board:

Step 5a -- Using a 1/8" drill bit, drill out the two rivets holding control board to electrical box. Clean debris.

Step 5b -- Remove the two red plugs and use a small screw driver to remove power wires.

Step 5c -- Use new 1/8" rivets or #6 screws to install replacement board.

Step 6 -- Reverse above steps to replace electrical components and to replace panel.

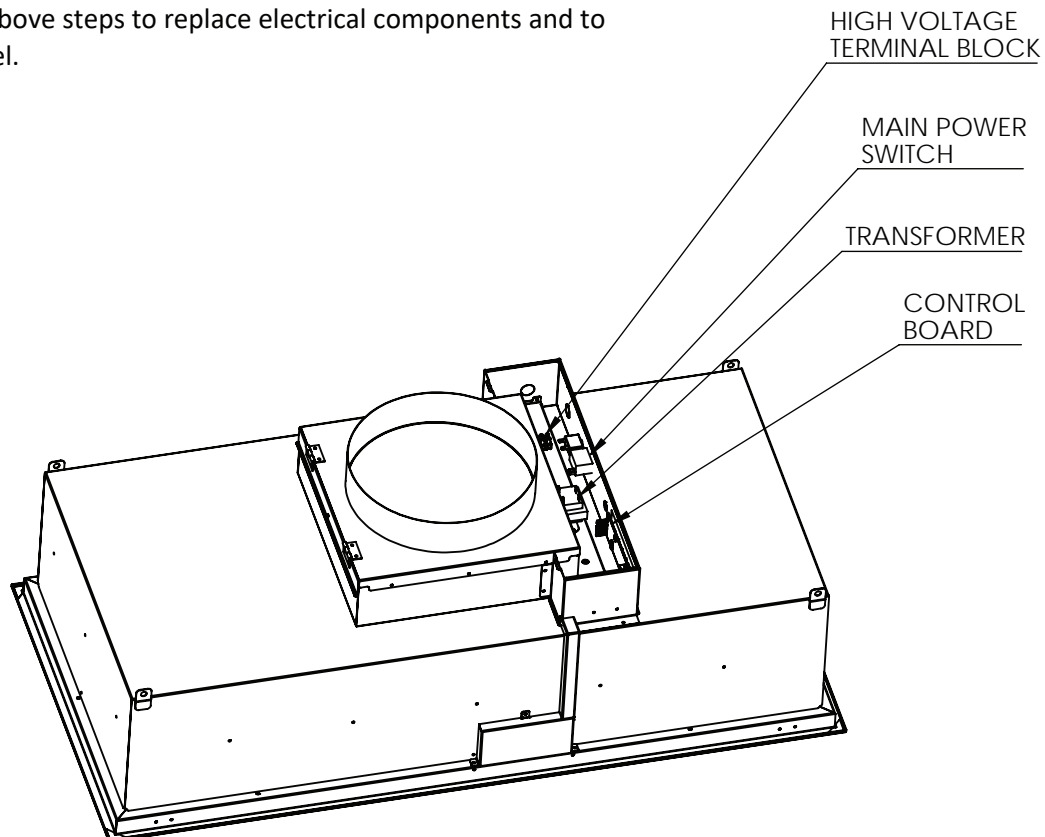

Access to Electrical Components (Room-Side Accessible Option)

WARNING!

Disconnect the unit from the electrical power source before attempting to service the unit.

Step 1 -- Using a flat screwdriver, release the face frame by rotating the four (4) fasteners a 1/4-turn counter clock-wise. Unhook the safety cables from the filter clips. Set the frame aside.

Step 2 -- Turn the unit off with the switch located on the frame of the unit.

Step 3 -- Disconnect the unit at the power source or at the service panel in accordance with OSHA (LOTO) practices and procedures.

Step 4 -- Remove the HEPA filter and the pre-filter and set aside. See sections 2 and 3 for instructions.

Step 5 -- Using a flat screwdriver, release the mid panel by rotating the three (3) fasteners a 1/4-turn counter clock-wise. Allow panel to swing down to vertical and remove from unit. Set aside.

Step 6 -- Use a 5/16" hex driver to remove screws holding electrical access panel (Find them in the \varnothing 1/4" round holes in foam). Slide panel over to release from the slots.

Step 7 -- To remove transformer:

Step 7a -- Disconnect all wires from terminals. See wiring diagram for replacing wires.

Step 7b -- Using a 1/8" drill bit, drill out the two rivets. Clean debris.

Step 7c -- Use new 1/8" rivets or #6 screws to install replacement transformer.

Step 8 -- To remove control board:

Step 8a -- Use a 5/16" hex driver to remove screws holding control board bracket.

Step 8b -- Remove the two red plugs and use a small screw driver to remove power wires.

Step 8c -- Using a 1/8" drill bit, drill out the two rivets holding control board to bracket. Clean debris.

Step 8d -- Use new 1/8" rivets or #6 screws to install replacement board.

Step 11 -- Reverse above steps to replace electrical components and to replace panels.

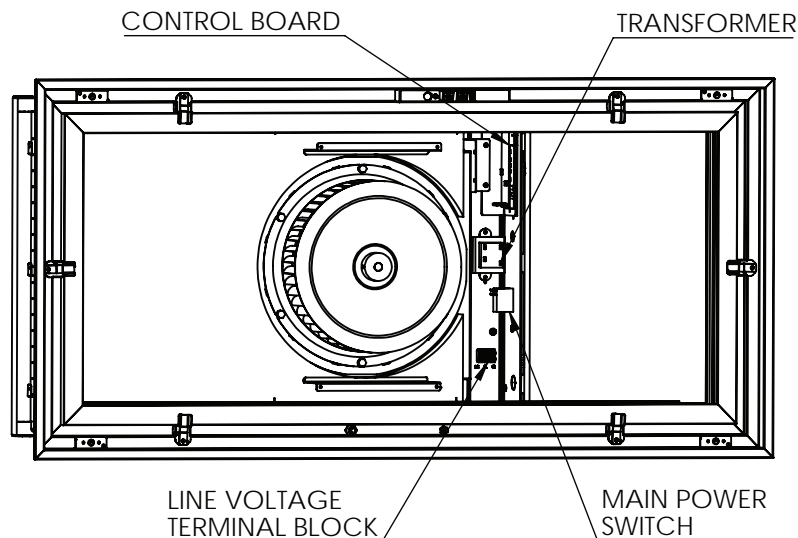

DUCTED APPLICATIONS & USE WITH VAV AIR TERMINALS

In applications where the fan filter unit will be installed downstream of variable airflow devices such as VAV boxes, air valves, or variable air handlers, proper care in unit set-up needs to be taken.

The unit should not be programmed to run as constant airflow in this application. Two variable controllers trying to reach their respective set point will continuously adjust. This will cause issues such as surging, starving, and eventual shut down of the fan filter unit. The units should be ordered with a constant torque program. This will remove the dirty filter ramp-up feature and the CFM display will no longer be accurate. However, this is still preferable to a PSC system due to the energy efficiency of an ECM versus a PSC motor.

Ducted applications While the fan filter unit can handle some positive or negative static pressure, optimal performance and reliability will be achieved with an inlet static pressure of 0.0" WC or slightly negative.

To reach an accurate 0.0"WC inlet static, it is recommended that the primary air balancing of the duct system be done before installing the fan filter unit. When the duct is at optimal static, install the unit per these instructions and adjust the airflow to the design setting. Verify the airflow with an airflow hood.

It is recommended that all FFUs in the system be energized before any upstream devices to prevent the FFU blower wheel from spinning backwards. While the motor can generally overcome this, if the airflow needed to overcome high static is too great, it may not. This will cause the motor to shut down. Continual running of the motor backward may result in reduced reliability of the EC motor.

NOTE: ON/OFF SWITCH AND DIGITAL CONTROL ARE HIDDEN WHEN FACE FRAME IS IN PLACE.

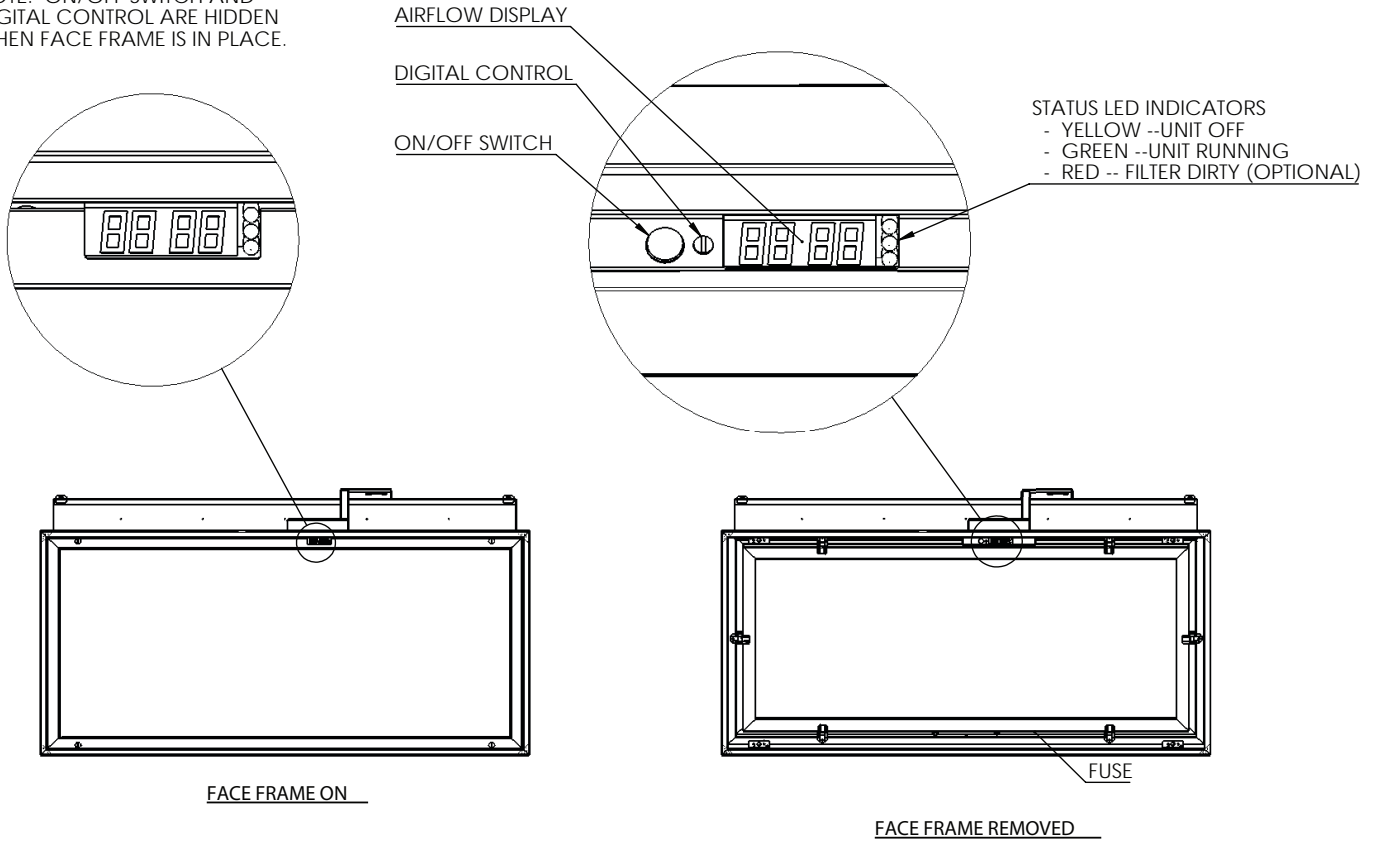

PAO CHALLENGE SYSTEM

An optional PAO Challenge Manifold System is available to provide a reliable, convenient method of performing a challenge test of the fan filter unit at the face.

**These instructions are to assist a qualified technician in testing the leakage of the fan filter unit. Filter should be installed for a minimum of 30 minutes before test is performed

Step 1 -- Using a flat screwdriver, release the face frame by rotating the four (4) fasteners a 1/4-turn counter clock-wise. Unhook the safety cables from the filter clips. Set the frame aside.

Step 2 -- Remove cap from PAO concentration port (brass). Attach UPSTREAM hose (1/4" ID) from photometer to PAO concentration port.

Step 3 -- Remove cap from PAO challenge supply port (aluminum). Attach DOWNSTREAM hose (3/8" ID) from photometer to PAO concentration supply port.

Step 4 -- Conduct the challenge test per equipment specifications and IEST-RP-CC034.3.

Step 5 -- Disconnect hoses from ports, and securely replace caps.

Step 6 -- Raise the face frame back into place, reattach the safety chains, and secure quarter-turn fasteners.

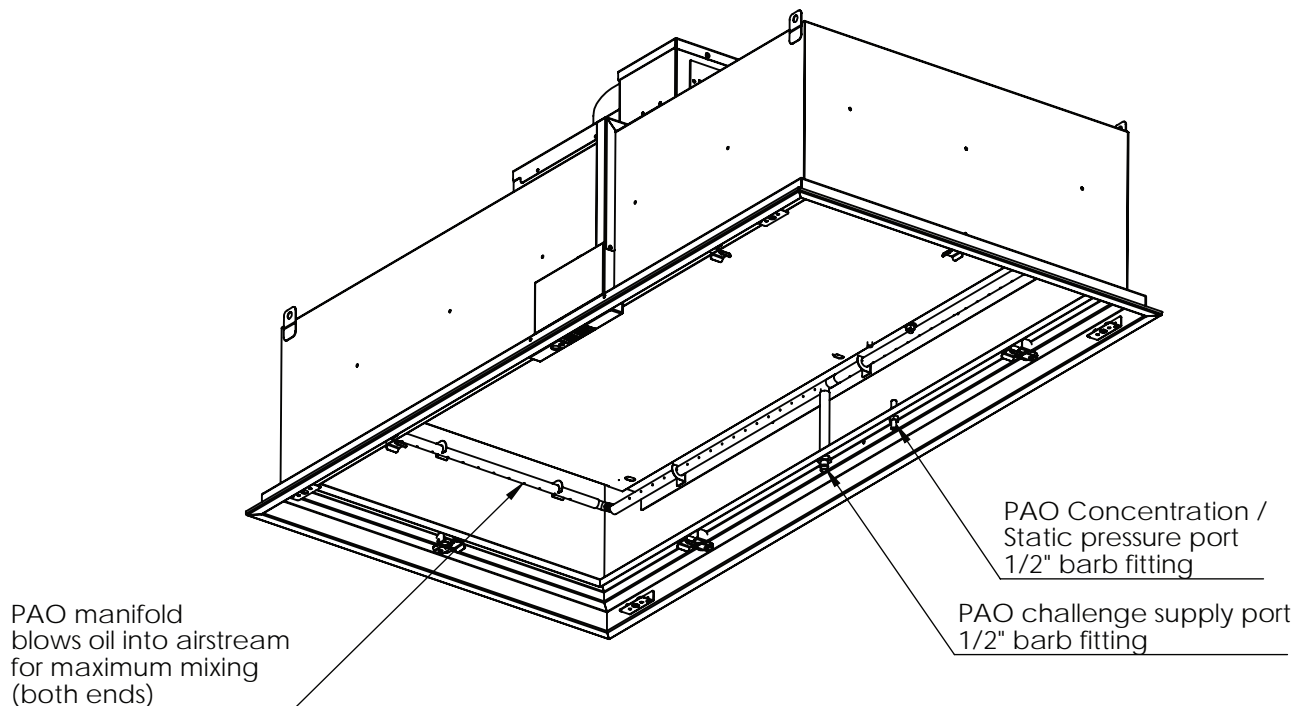

CONTROLS

The fan filter unit can be controlled through various inputs:

1. Local potentiometer control
 - Adjust airflow from the face
 - Adjust flow from back of unit (disabled if face control present)
2. Individual unit wall mounted control (must be determined before ordering)
3. 0 - 10V/0 - 5V DC Control
4. 0 - 20mA/4 - 20mA Control
5. Full range of network controls including connection to BAS/BMS through MODBUS RTU RS485 control
 - BACNet IP, BACNet MS/TP, & LONWorks available with additional hardware

Additionally, monitoring and control of the FFU can be done through closed loop control from sensors such as pressure transducers, thermostats, particulate counters, etc.

This manual will give basic information on how to connect controls and sensors to the unit. For more details refer to the instructions included with the controller or sensors.

WALL MOUNT POTENTIOMETER CONTROL

Potentiometer and wall plate are provided with this option. It is factory hard wired and tested.

Signal is 0-10VDC. Potentiometer is 0-10K Ohms.

To relocate the potentiometer cut the wires leaving enough lead to make new connections. Run 3 conductor wire rated for the requirements of the installation and meeting all relevant codes. If possible, use strain relief at the fan filter unit.

Connect wires like to like at each end of the extension leads. Retest unit to verify operation.

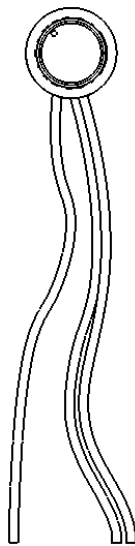

NETWORKING

When networking the fan filter units either in a local area network (LAN) or connecting to a BAS/BMS system, each unit is connected in a "straight-through" daisy-chain using Cat5e or Cat6 network cables and the on-board RJ45 connectors.

If field cutting network cables, it is important for each end of the cable to be wired identically. However, assembled network cable are available; field assembled cables are the leading cause of problems in new systems.

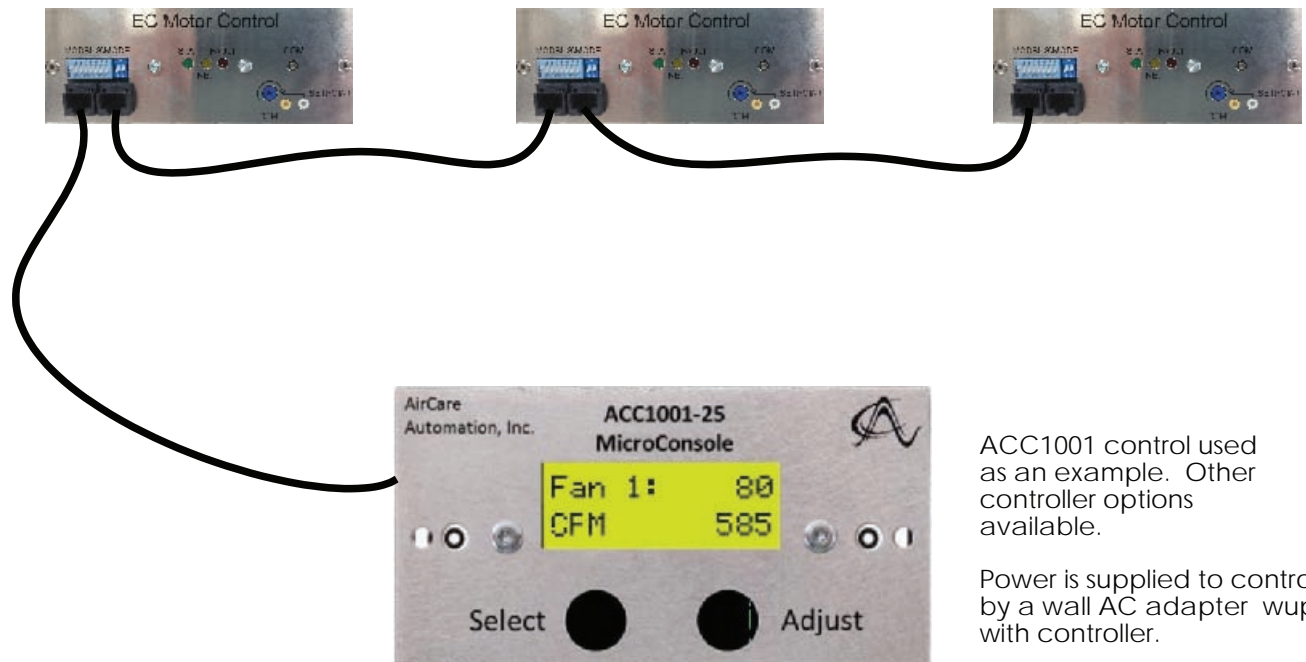

ACC1001 control used as an example. Other controller options available.

Power is supplied to controller by a wall AC adapter wupplied with controller.

1. RJ45 Dual Jacks
2. Modbus Address DIP Switches
3. S1-1 and S1-2 Configuration DIP Switches
4. STATUS LED
5. NET LED (network activity)
6. FAULT LED
7. Multimeter Common
8. Multimeter Setpoint as mVDC
9. Multimeter CFM as mVDC
10. Onboard Setpoint Potentiometer

- A. JPS: Bias input power, isolated
- B. JP2: Accessory output voltages
- C. JVDC: Selector for 10V regulated or unregulated rectified and filtered bus voltage
- D. J1: EC Motor Port
- E. JVS-1: INP1 10V signal range selector
- F. JP1: INP1 and INP2 analog/digital inputs
- G. JVS-2: INP2 10V signal range selector
- H. JLED: External FAULT output
- J. JPUD2: INP2 digital input pull-up or 20mA signal format selector
- K. JPUD1: INP1 digital input pull-up or 20mA signal format selector
- L. JP420: 0-20mA or 4-20mA signal format selector
- M. JFBS: TACH or Analog 2 feedback signal selector
- N. Aux Board Port

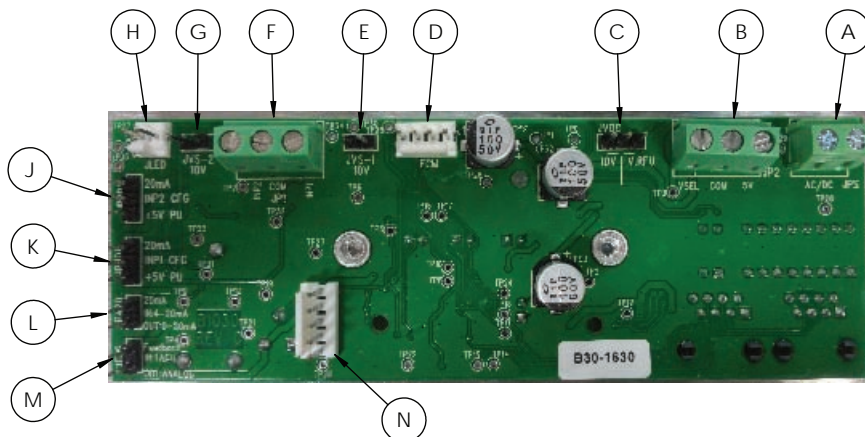
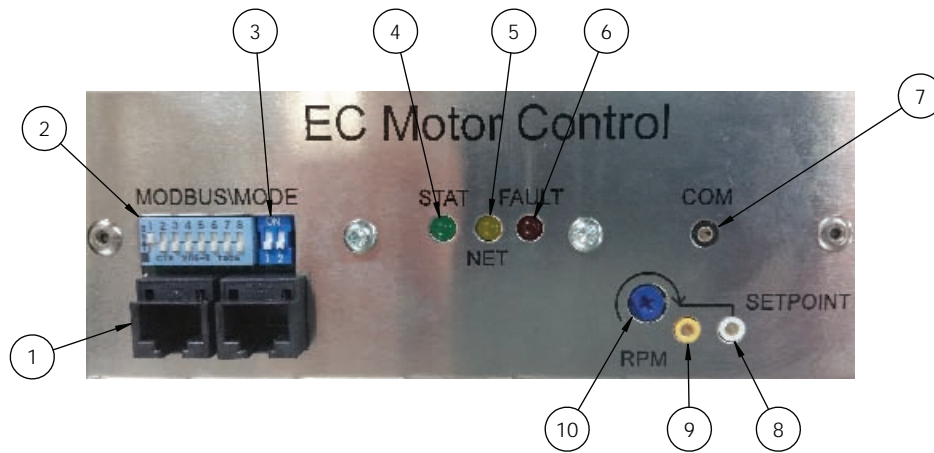

NETWORKING

DIP SWITCH SETTINGS

Each fan filter unit in a network must be set to a unique address between 1 and 247. Addresses 248- 255 are declared reserved per MODBUS protocol. A DIP switch block of eight switches are used for addressing. The control board supports Modbus Broadcast Address Zero for single and multiple register write commands (Modbus Function Codes 6 and 16).

Address settings are checked by the board controller only at power-up, so power must be cycled before any changes take effect.

Analog input setpoint modes preserve the ability to monitor and modify register values using a suitable controller console or PLC.

Therefore, addressing may be relevant for configuration, monitoring and/or troubleshooting even when units are intended to be used with analog setpoint input.

Address Selection

When adjusted to the ON position, each DIP switch pole represents a value as follows:

DIP Switch Pole	Value
1	1
2	2
3	4
4	8
5	16
6	32
7	64
8	128

Calculate the address value of existing switch settings by adding the values of each DIP switch pole in the ON position, per the table at left.

Construct switch settings for a desired address value by successively subtracting the largest pole value that is less than the desired address value, repeating with each remainder until the remainder is zero. An example is provided below.

Example: Desired address is 114

$$114 - 64 = 50 \text{ SW 1-7 ON}$$

$$50 - 32 = 18 \text{ SW 1-6 ON}$$

$$18 - 16 = 2 \text{ SW 1-5 ON}$$

$$2 - 2 = 0 \text{ SW 1-2 ON}$$

$$64 + 32 + 16 + 2 = 114$$



1



2



3



30

*See page 23 for more examples

CONFIGURATION DIP SWITCHES S1-1 & S1-2

Switch	S1-1	S1-2
	Control Loop Mode	Setpoint Source
OFF	Open-Loop Control	Analog Setpoint
ON	Closed-Loop Control	Network Setpoint

Open-Loop -- Fan filter unit is controlled by a controller, i.e. on-board potentiometer or network controller.

Closed-Loop -- A sensor is used to maintain airflow, i.e. room pressure, roomtemp, or a particle counter.

Analog Setpoint -- Unit is controlled with an analog controller, i.e. on-board potentiometer or individual wall mounted controller (must be determined before ordering)

Network Setpoint -- Unit is controlled with a networked controller, i.e. ACC1 or ACM7052 touchscreen controller

SENSOR SHUNT TABLES

Shunt	JP420	JFBS	JVS-1*	JVS-2*
OUT	0 - 20mA	ANALOG	0 - 5VDC	0 - 5VDC
IN	4 - 20mA	N/A	0 - 10VDC	0 - 10VDC

*Leave shunt out if using a 0-20mA or 4-20mA sensor.

Shunt Table for JP1 wiring block

Center Pin to...	JPUD1:INP1	JPUD2:INP2
No connection	ANALOG 5V or 10V	ANALOG 5V or 10V
20mA	ANALOG 20mA	ANALOG 20mA
+5V PU	DIGITAL 10kΩ pull-up TO 5V	DIGITAL 10kΩ pull-up TO 5V

Shunt Table for JP2 wiring block

Center Pin to...	JVDC
No Connection	VSEL = no connection; open
10V	VSEL = 10V regulated
V.RFU	VSEL = DC filtered, unregulated, ~33VDC

NOTES:

- JP1 is for signal input
- JP2 is for output power
 - connect COM/5V --> 5V power supplied
 - connect COM/VSEL with 10V shunt --> 10V power supplied
 - connect COM/VSEL with V.RFU shunt --> Full wave rectified power supplied (~33VDC)
- INP1 on JP1 wiring block is for monitoring only
 - 0 - 10VDC
 - 0 - 5VDC
 - 0 - 20mA
 - 4 - 20mA
- INP2 on JP1 wiring block is for closed-loop feedback or monitoring
 - Controlling airflow by room pressure or particle counter

EXAMPLE OF WIRING A PRESSURE TRANSDUCER TO CONTROL BOARD FOR FEEDBACK OR MONITORING THROUGH CONTROLLER

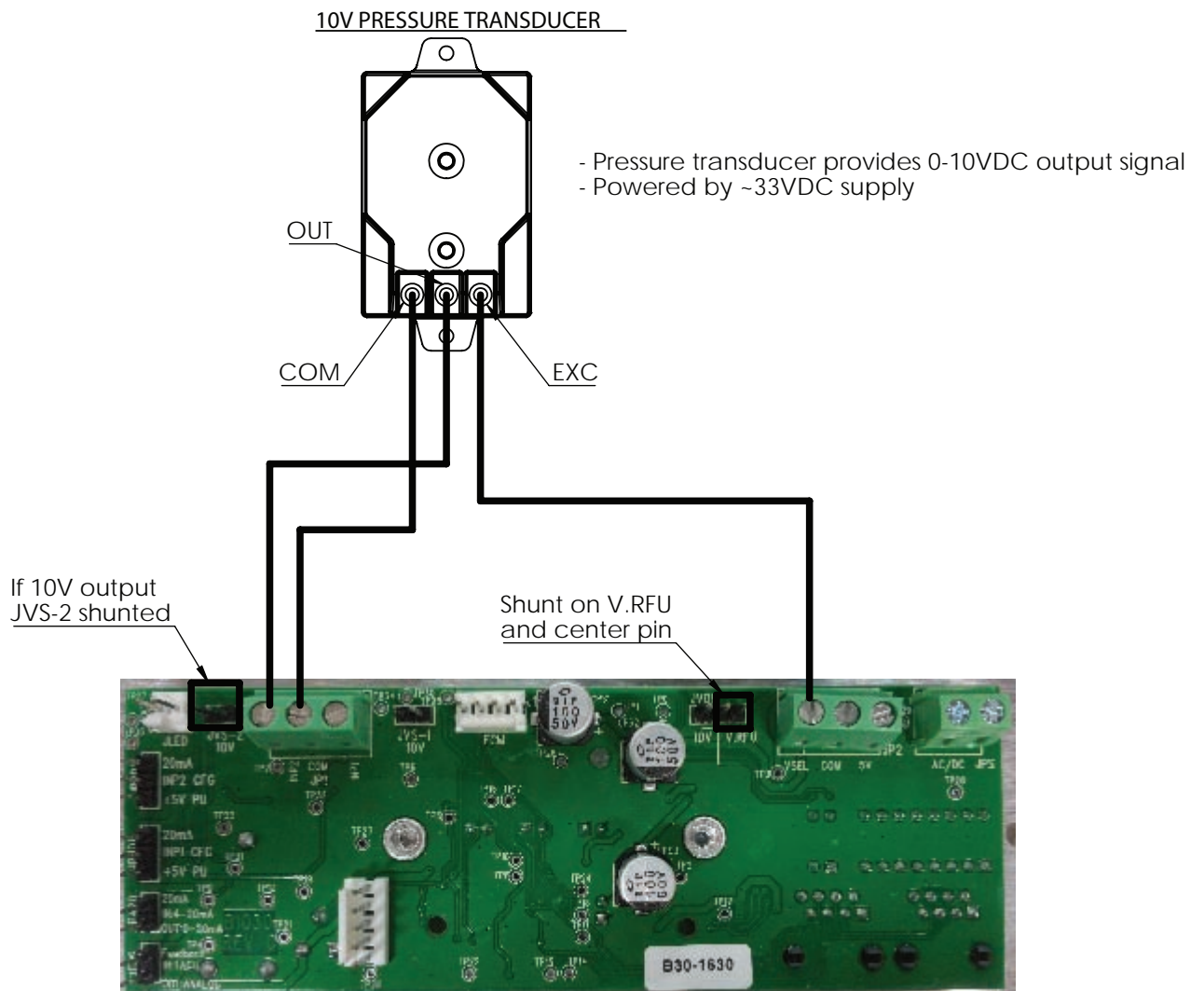

EXAMPLE OF WIRING A SENSOR TO CONTROL BOARD FOR FEEDBACK OR MONITORING THROUGH CONTROLLER

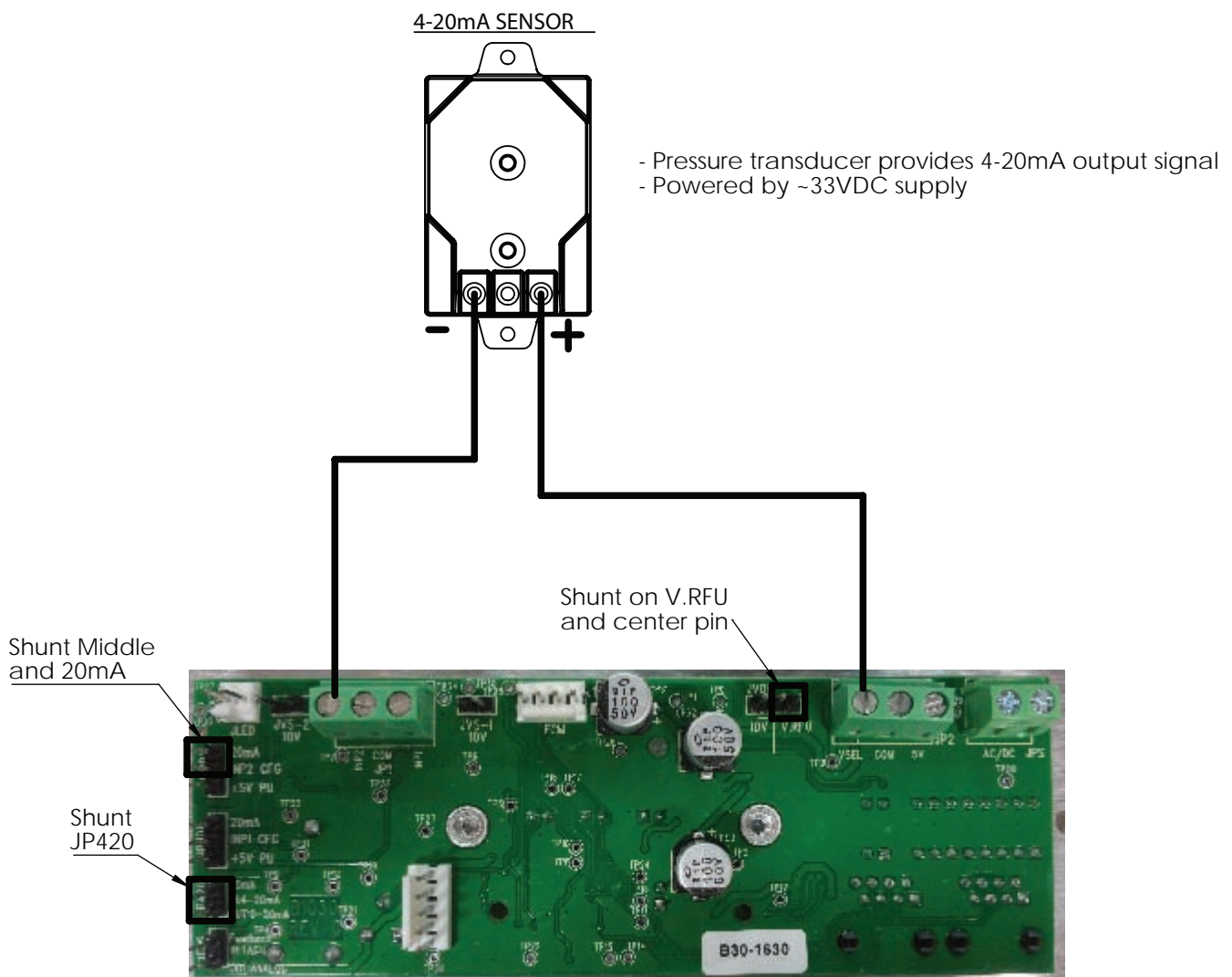

RESETTABLE FUSE/MAIN POWER SWITCH

Each fan filter is equipped with an 8 Amp resettable fuse to protect the unit from electrical spikes. The fuse is located on the plaster frame opposite the display.

The main power switch is located on the electrical on the backside of the unit. An additional disconnect can be added by others per local codes and regulations.

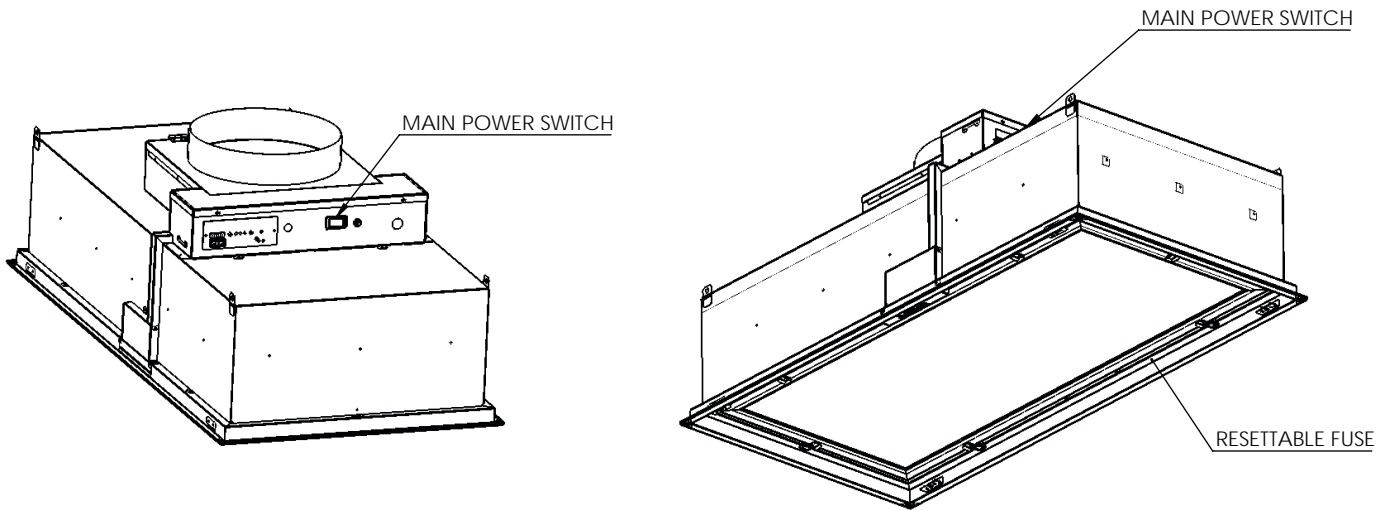

NOTE : If unit is installed in an area with no access above the ceiling, the main power switch must be turned on before installing into the ceiling.

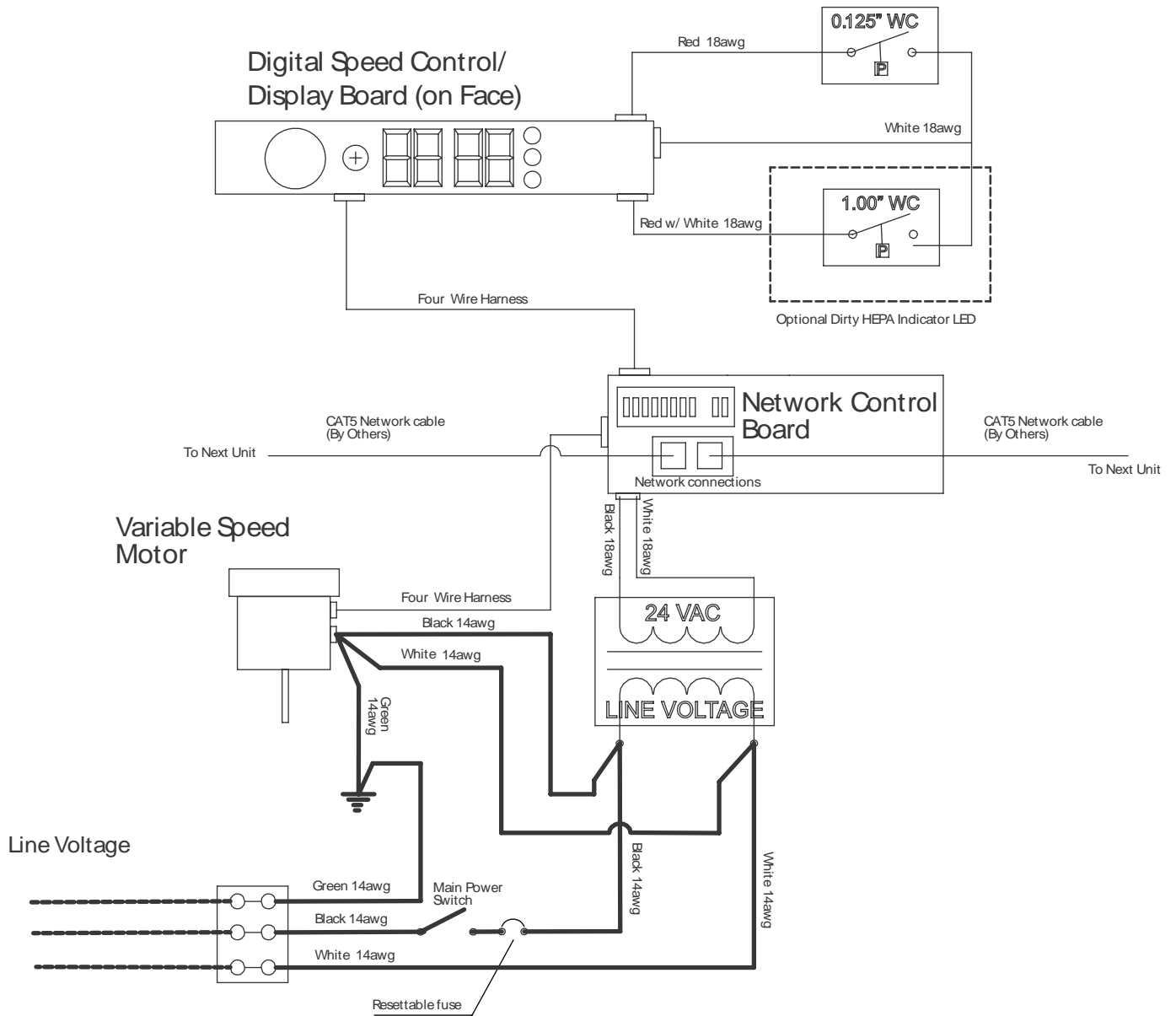

TYPICAL FFU-2 ELECTRICAL WIRING (Plenum Side)





Legend

-  LINE VOLTAGE (By Others)
-  LINE VOLTAGE
-  24 VAC

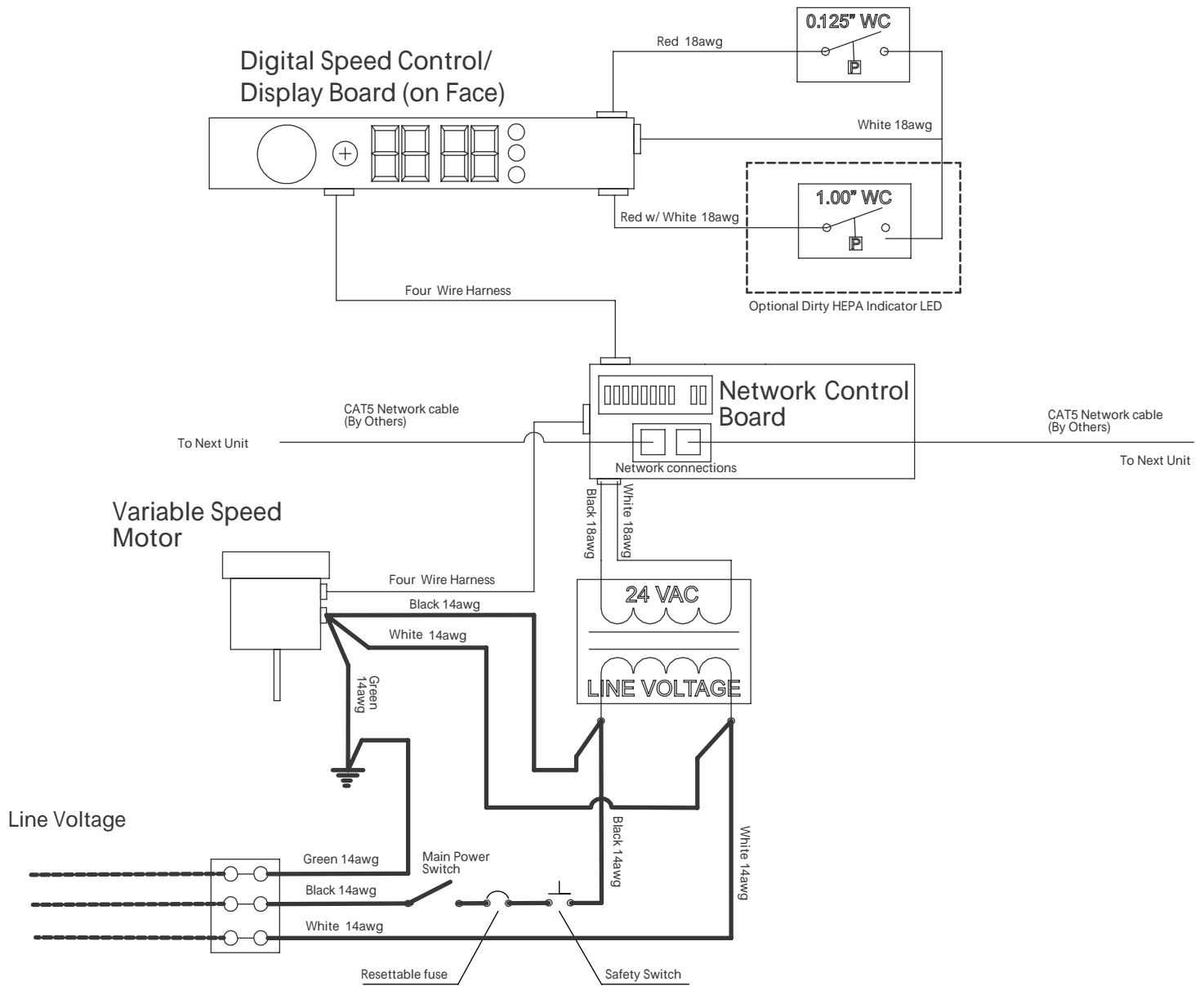
TYPICAL ELECTRICAL WIRING DIAGRAM (MOTOR / ELECTRONICS ROOM-SIDE ACCESSIBLE)



Legend

-  LINE VOLTAGE (By Others)
-  LINE VOLTAGE
-  24 VAC

DIP SWITCH SETTINGS FOR UP TO 30 FAN FILTER UNITS
FOR MORE UNITS SEE BELOW.

Calculate the address value of existing switch settings by adding the values of each DIP switch pole in the ON position, per the table below.
Construct switch settings for a desired address value by successively subtracting the largest pole value that is less than the desired address value, repeating with each remainder until the remainder is zero. An example is provided below.

DIP Switch Pole	Value
1	1
2	2
3	4
4	8
5	16
6	32
7	64
8	128

Example: Desired address is 114

114 - 64 = 50 SW1-7 ON
50 - 32 = 18 SW1-6 ON
18 - 16 = 2 SW1-5 ON
2 - 2 = 0 SW1-2 ON

64 + 32 + 16 + 2 = 114

	10		20		30
	9		19		29
	8		18		28
	7		17		27
	6		16		26
	5		15		25
	4		14		24
	3		13		23
	2		12		22
	1		11		21

Cleaning the Fan Filter Unit Pre-filter (when applicable)

WARNING!

Disconnect the unit from the electrical power source before attempting to service the unit.

Note: For maximum performance, wash pre-filter every three to six months at a minimum.

Step 1 -- Turn the unit off with the rocker switch located on the unit.

Step 2 -- Disconnect the unit at the power source or at the service panel in accordance with OSHA (LOTO) practices and procedures.

Step 3 -- Using a driver, remove the screw holding the hinged door. This allows access to the pre-filter. Slide the pre-filter out of the motor enclosure. This step is not applicable if unit is non-ducted.

Step 4 -- Wash the filter with hot water and a mild detergent and rinse thoroughly. Do not use a caustic solution to clean the filter. Blow dry or let air dry and slide the filter back into the motor enclosure. Filter should be completely dry before reinstalling into unit.

Step 5 -- Using the driver, re-secure the cover with the screw.

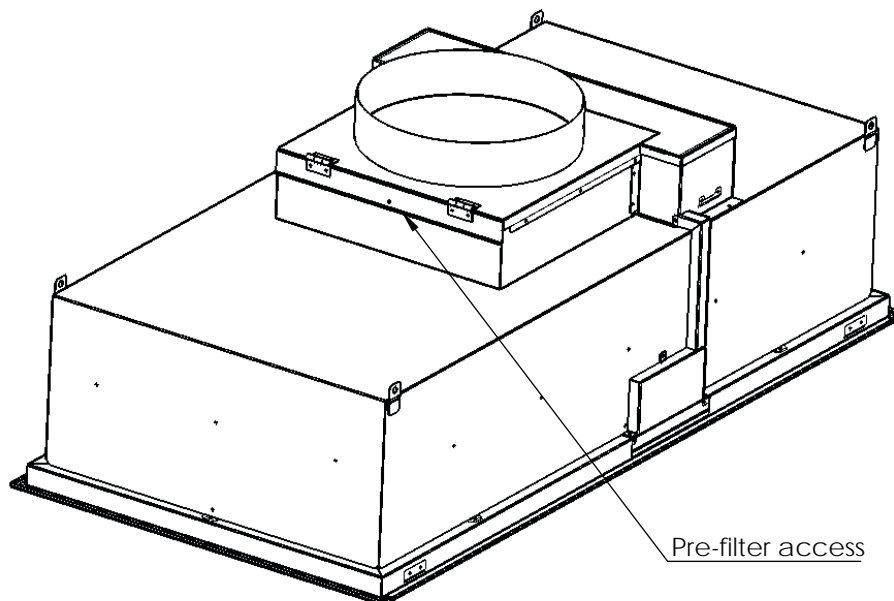

Testing

Each fan filter unit is thoroughly tested at the factory before shipment. However, many codes and standards require testing for bypass leakage after installation. The manufacturer encourages that the customer contact an independent, certified testing organization with technicians that are trained and experienced in performance, evaluation, and maintenance of clean air equipment.

The manufacturer recommends at least 30 minutes elapse after HEPA/ULPA filter installation before performing any type of challenge leak testing. The unit should be sealed to the ceiling and the room should have a positive pressure held during testing and normal operation.

Trouble Shooting

Low Airflow

- If optional red HEPA-alert LED light is on, replace the HEPA filter.
- Inspect the pre-filter. Clean or replace as necessary.
- Adjust the digital speed control for higher airflow output.
- Check the power supply for proper voltage, amperage, and distribution frequency
- Verify dip switches are correct for type of controls used.
- Replace HEPA filter if airflow remains low.

High Airflow

- Adjust digital speed control for lower output.
- Verify dip switches are correct for type of controls used.

Non-Laminar Airflow and/or Excessive Contamination

- Insure that upstream airstream is clear of large obstructions.
- Ensure that no other air moving devices are operating in such a way to disrupt the room's airflow pattern.
- Check airflow and if not desired airflow see above.
- Conduct smoke or photometer test on HEPA filter and gel seal. If fail seal or replace the HEPA filter as necessary.