



# Anemostat®

AIR DISTRIBUTION

## SUBMITTAL SHEET

www.anemostat-hvac.com



Model **HD3**  
**HEAVY DUTY**  
**RETURN GRILLES**

### PRODUCT FEATURES

- 1/2" or 3/4" Blade spacing
- Registers include a factory attached steel opposed blade volume control damper
- Surface mounted holes in frame neatly countersunk for supplied #8 x 1-1/2" oval head screws
- 16 GA Steel Frame / 14 GA Support Bars
- Heavy-Duty Blades

### CONSTRUCTION DETAILS

#### Material:

- Steel Construction
- 304 SS Construction

#### Finish:

- Arctic White (std)
- Custom Color (opt)

### Models

- HD30** 3/4" Blade Spacing
- HD35** 1/2" Blade Spacing
- 0° Deflection
- 40° Deflection

### Accessories

- OB-1** Opposed Blade Damper

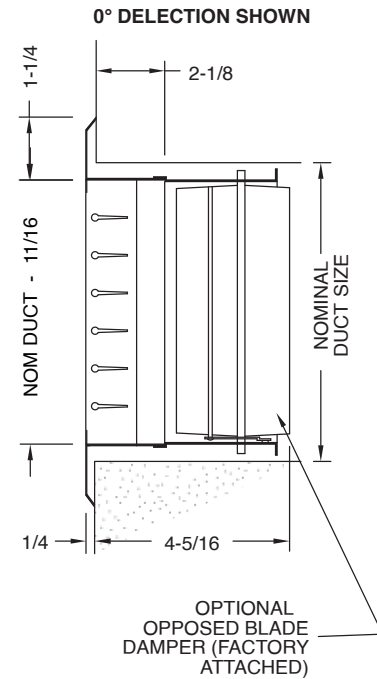
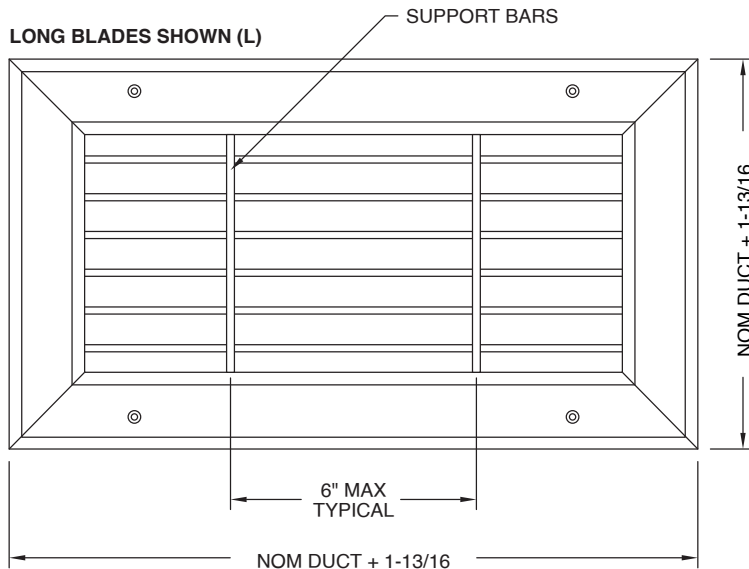

SHORT BLADES (S)

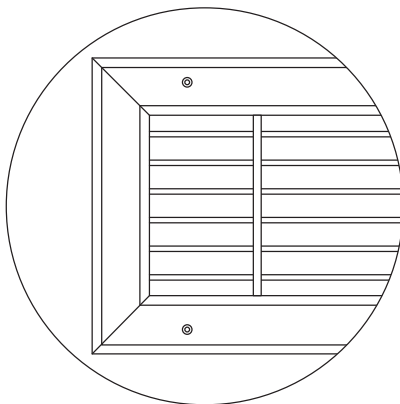

0° DEFECTION, 1/2" SPACING

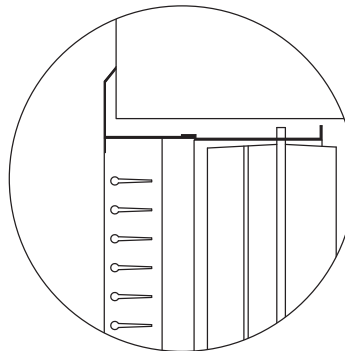

40° DEFECTION, 1/2" SPACING

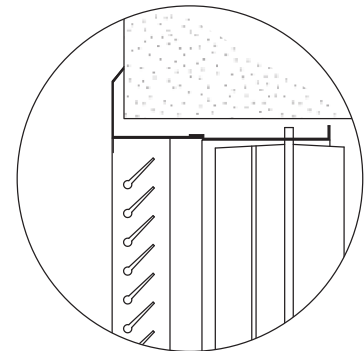

All dimensions are in inches.

JOB NAME:

SUBMITTED BY: