



# Anemostat®

## SUBMITTAL

A MESTEK COMPANY

1220 Watson Center Road • Carson, CA 90745-4206  
 (310) 835-7500 • FAX (310) 835-0448  
 airhelp@anemostat.com • www.anemostat.com

### Model **HCR**

## HIGH CAPACITY RADIAL DIFFUSERS

### SIDE INLET

# DIFFUSERS

### PRODUCT FEATURES

- Installs flush to the ceiling as a single, fully gasketed module – no field assembly required
- 180° & 90° radial patterns available for design flexibility
- Unique, manually adjustable pattern controller to “fine tune” pattern based on design air flow rate, cooling differential, and application
- Removable face via 1/4 turn fasteners for cleaning
- Face is hinged and swings down 90° for easy cleaning. Safety cables prevent face from accidentally swinging down.
- Closed cell gasket prevents leakage around face

### MATERIAL AND FINISH

#### Distribution Panel:

- Steel with White Baked Epoxy
- Aluminum with White Baked Epoxy
- 304 Stainless Steel, #4 Polish
- 304 Stainless Steel with White Baked Epoxy

#### Dual Chamber Plenum:

- Steel with White Baked Epoxy
- Aluminum with White Baked Epoxy
- 304 Stainless Steel, 2B Mill Finish
- 304 Stainless Steel with White Baked Epoxy

### MODELS

- HCR-T** Lay-In T-Bar
- HCR-P** Surface Mounted

### PATTERN

- Type 1** - 90°
- Type 2** - 180°

### ACCESSORIES

- Volume Damper** Non-Removable
- Volume Damper** Removable

#### Model HCR-T Lay-In T-Bar

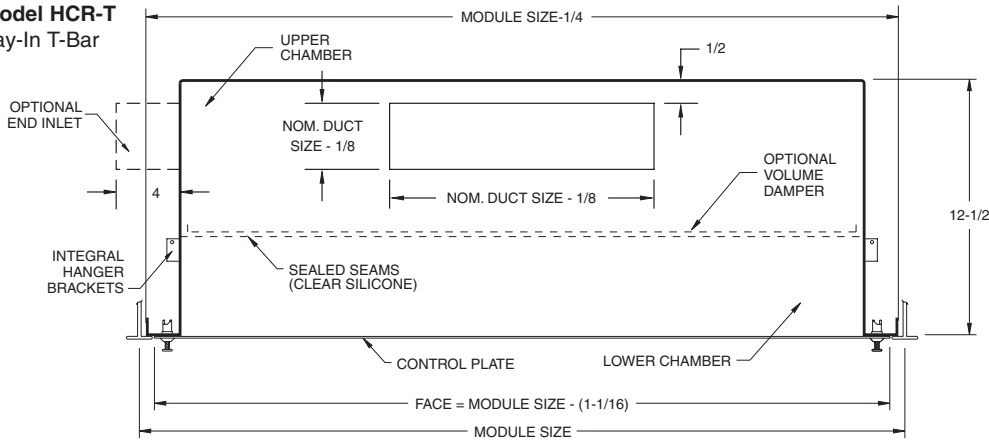

HCR DIMENSIONS		
Size	Nom. Size	Nom. Duct Size*
124	12 x 48	12 x 6 18 x 6 24 x 6
242	24 x 24	
244	24 x 48	

\*Other neck sizes available. Contact factory.

#### Model HCR-P Surface Mounted

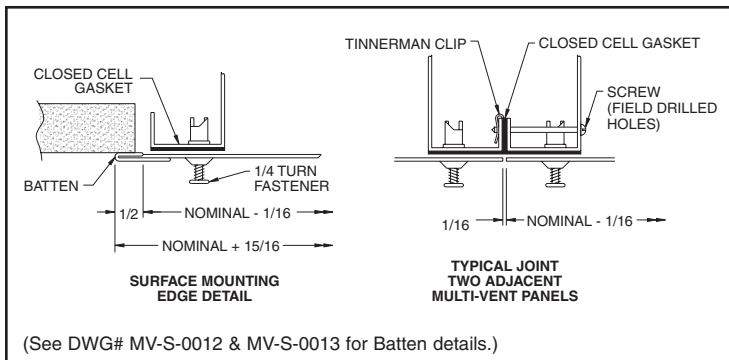

#### Type 1 90° Pattern

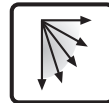

#### Type 2 180° Pattern

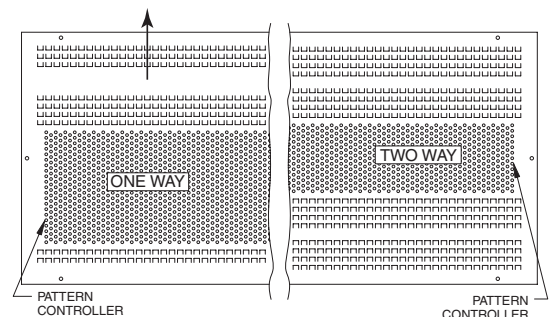

All dimensions are in inches.

JOB NAME:

SUBMITTED BY: