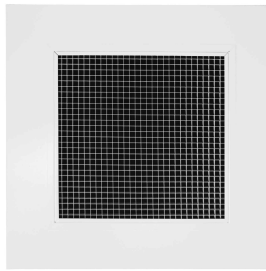

SUBMITTAL SHEET

 Model **GC5-L**
GRID CORE RETURN

1/2" X 1/2" X 1/2" CORE

LAY-IN T-BAR
WITH EXTENSION PANEL
PRODUCT FEATURES

- 1/2" x 1/2" x 1/2" aluminum core
- Registers include a factory attached, steel opposed blade volume control damper

CONSTRUCTION DETAILS
Material: All Steel Components with Aluminum Core (**std**)

Finish:

- Arctic White (**std**)
- Custom Color (opt)

Extension Panel

- A** 06" x 30" Module
- B** 06" x 48" Module
- 11** 12" x 12" Module
- 12** 12" x 24" Module
- 22** 24" x 24" Module
- 24** 24" x 48" Module
- 30** 30" x 30" Module

Accessories

- OB** Opposed Blade Damper

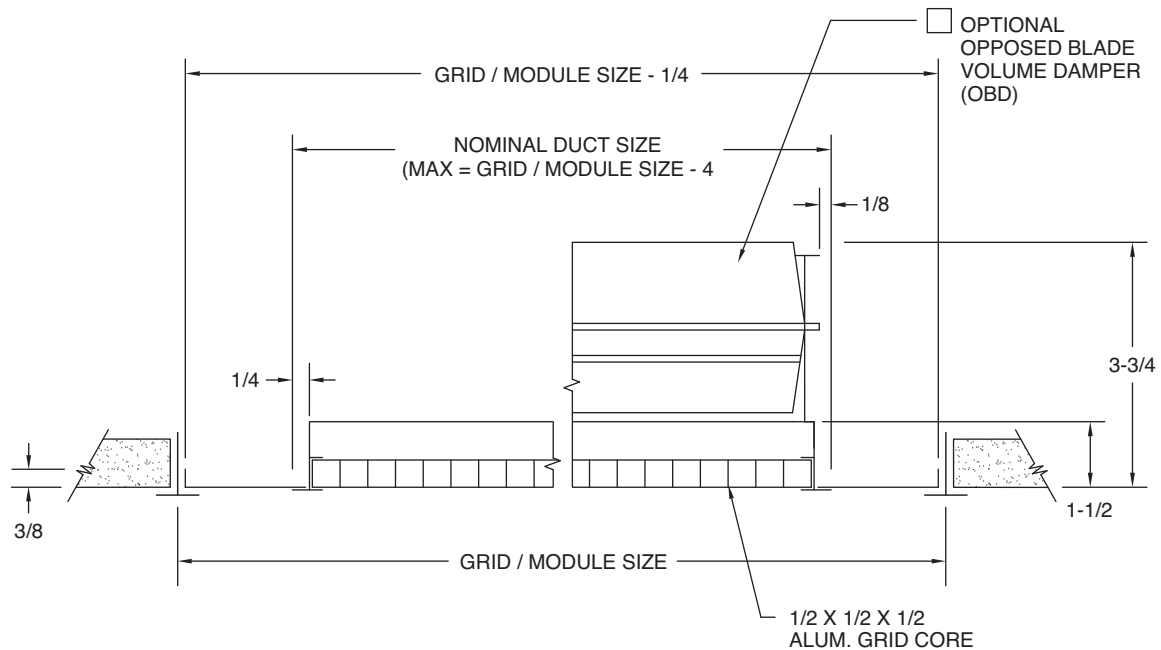

GRID / MODULE SIZE	MAX NECK SIZE
12 x 12	8 x 8
12 x 24	8 x 20
24 x 24	20 x 20
24 x 48	20 x 44
48 x 48	44 x 44

NOTE: For Nominal Neck Size = Grid / Module Size - 2, use GC5 surface mounted unit without screw holes in border.

All dimensions are in inches.

JOB NAME:
SUBMITTED BY: