



Anemostat®

AIR DISTRIBUTION

SUBMITTAL SHEET

www.anemostat-hvac.com



SOUND ATTENUATOR

RECTANGULAR
LOW FREQUENCY
FIBERGLASS FILL

PRODUCT FEATURES

- **FILL:** Fiberglass under compression
- Tested in accordance with ASTM E-477
- Single piece construction from:
6" x 6" to 48" x 48"
- **ASTM-E84 Rating Characteristics:**
Flamespread - 10
Smoke Developed - 10

CONSTRUCTION FEATURES

- **Casing:**
22 Gauge Galvanized Steel
- **Baffles:**
24 Gauge Perforated Galvanized Steel

MODELS

- ALUHP** Ultra High Pressure
- ALHP** High Pressure
- ALMHP** Medium High Pressure
- ALMP** Medium Pressure
- ALMLP** Medium Low Pressure
- ALLP** Low Pressure
- ALULP** Ultra Low Pressure

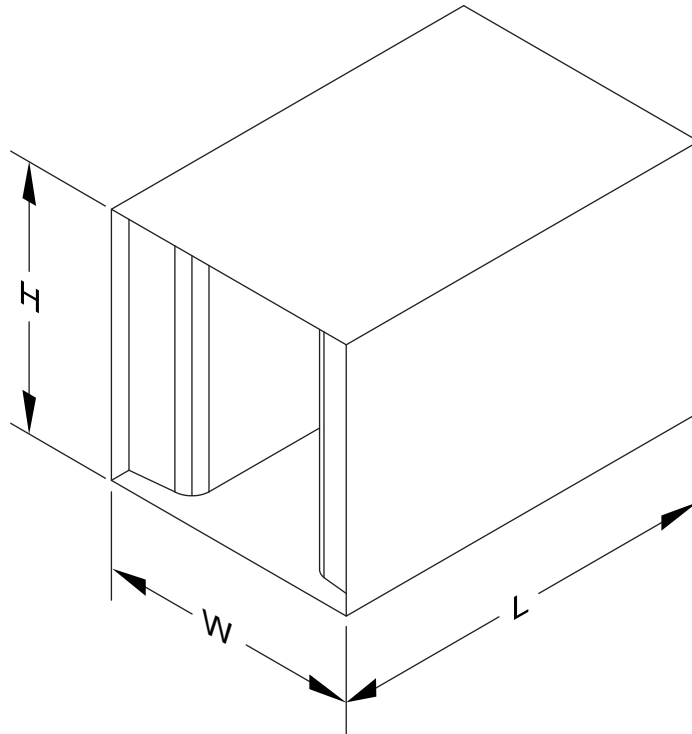

By *AEROSONICS*

All dimensions are in inches.

JOB NAME:

SUBMITTED BY: