

APPLICATION

- Surface mounted perforated return / exhaust grille

PRODUCT FEATURES

- Face pattern with 3/16" diameter holes on 1/4" centers with 51% free area
- Mounting holes in frame neatly countersunk for supplied #8 x 1-1/2" oval head screws
- Registers include a factory attached, steel opposed blade volume control damper
- Aluminum models constructed from extrusion
- Arctic White baked-on finish
- Maximum size is 48" x 48" in one piece construction. Sizes over 48" are shipped in multiple sections for field assembly

GRILLE OPTIONS

- Steel, aluminum, or stainless steel construction
- Filter grille option
- Custom or optional paint colors
- Factory applied gasket material to frame
- Aluminum opposed blade volume control dampers

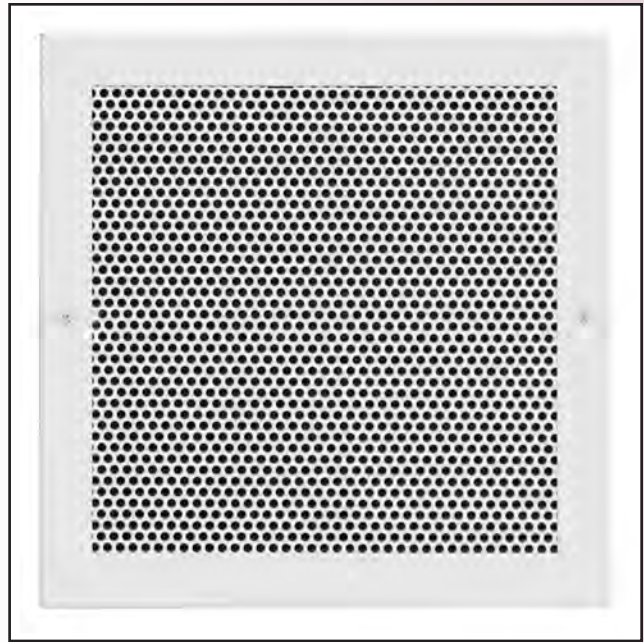

Model 3P

SURFACE MOUNTED

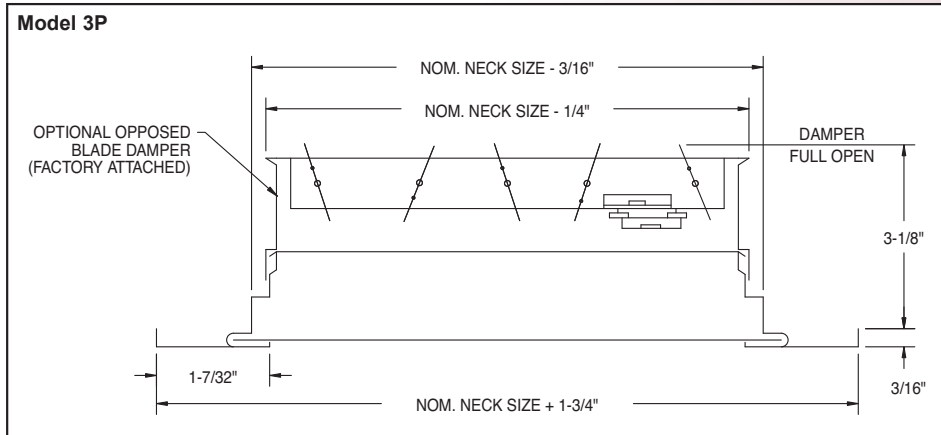

HINGED FILTER GRILLE, SURFACE MOUNTED

