

# ANEMOSTAT<sup>®</sup>

ELECTRONIC VAV DIFFUSERS

## Control Package PvV - D01

- VAV COOLING ONLY
- PRESSURE DEPENDENT
- BACNET INTERFACE
- DIGITAL WALL SENSOR / CONTROLLER

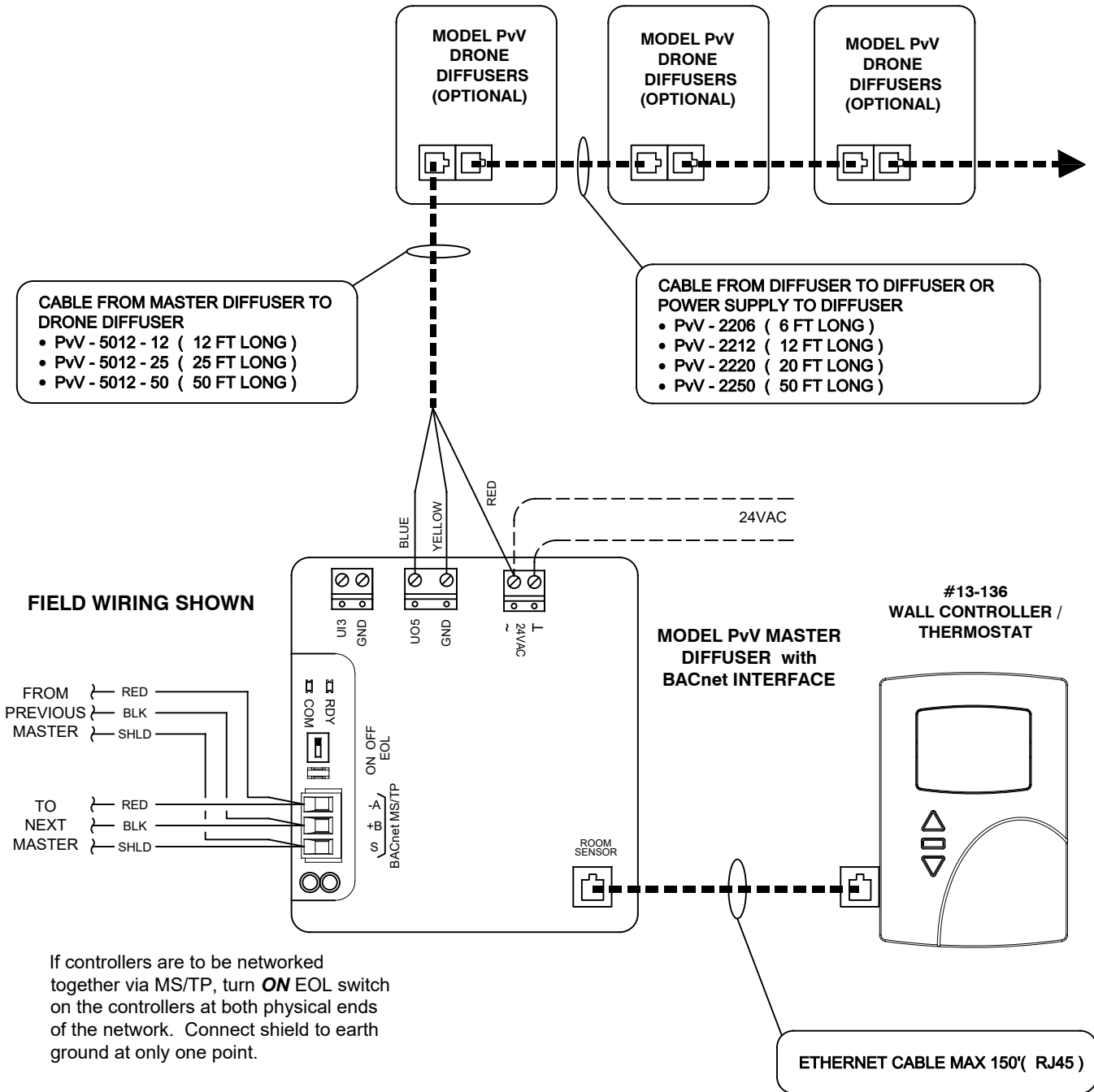

If controllers are to be networked together via MS/TP, turn **ON** EOL switch on the controllers at both physical ends of the network. Connect shield to earth ground at only one point.

**NOTES:**

- THE # OF DIFFUSERS CONTROLLED BY A SINGLE WALL SENSOR IS DETERMINED BY CABLE LENGTHS.

**JOB NAME:**  
**SUBMITTED BY:**  
**DATE:**

**DWG #: PVV-D01.1**  
**REV: -**  
**DATE: 9-7-18**

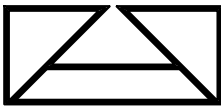

- VAV COOLING ONLY
- PRESSURE DEPENDENT
- BACNET INTERFACE
- DIGITAL WALL SENSOR / CONTROLLER

## COOLING MODE

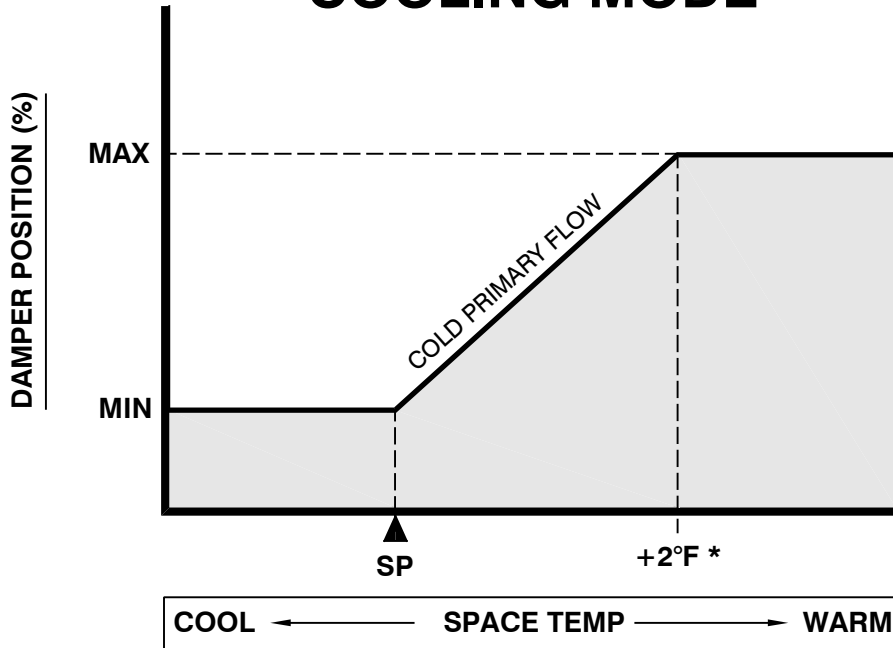

\* PROPORTIONAL BAND (PROP DB) DEFAULT AT 2°F, ADJUSTABLE

## SEQUENCE OF OPERATION

THE WALL CONTROLLER / T'STAT SIGNALS THE DIFFUSER ACTUATOR IN RESPONSE TO THE SPACE TEMPERATURE. NOTE UPON INITIAL POWER UP, THE DIFFUSER ACTUATOR WILL PERFORM A SELF-CALIBRATION ROUTINE. USER ADJUSTS WALL CONTROLLER FOR DAMPER POSITION BASED ON PERCENTAGE OF DAMPER OPEN. ALL DRONE DIFFUSERS FOLLOW SAME DAMPER POSITION AS THE MASTER DIFFUSER.

### COOLING

1. THE THERMOSTAT D.A. COOLING OUTPUT CONTROLS FLOW ( COOLING MODE) . WITH SPACE TEMPERATURE BELOW THE THERMOSTAT SETPOINT, MINIMUM DAMPER POSITION IS MAINTAINED AS SET BY MIN COOLING DAMPER %.
2. AS THE SPACE TEMPERATURE INCREASES FROM SETPOINT TO 2°F ABOVE SETPOINT, THE DAMPER OPENS FROM MINIMUM POSITION ( % MIN) TO MAXIMUM POSITION ( % MAX) . AT OVER 2°F ABOVE SETPOINT, MAXIMUM DAMPER POSITION IS MAINTAINED.

REFER TO WALL CONTROLLER INSTRUCTIONS FOR ACCESS TO MENUS AND SETTINGS. MIN AND MAX COOLING % CONTROL THE DAMPER POSITION. UPON LOSS OF POWER, DAMPER FAILS IN PLACE.

JOB NAME:  
SUBMITTED BY:  
DATE:

DWG #: PVV - D01.2  
REV: -  
DATE: 9-7-18