

# ANEMOSTAT®

ELECTRONIC VAV DIFFUSERS

Control Package  
**PvV - A02**

- AUTO HTG-CLG CHANGEOVER
- VAV HEATING & COOLING
- PRESSURE DEPENDENT
- ANALOG ELECTRONIC CONTROLS
- AIR FLOW SETPOINTS ADJUSTED AT THERMOSTAT

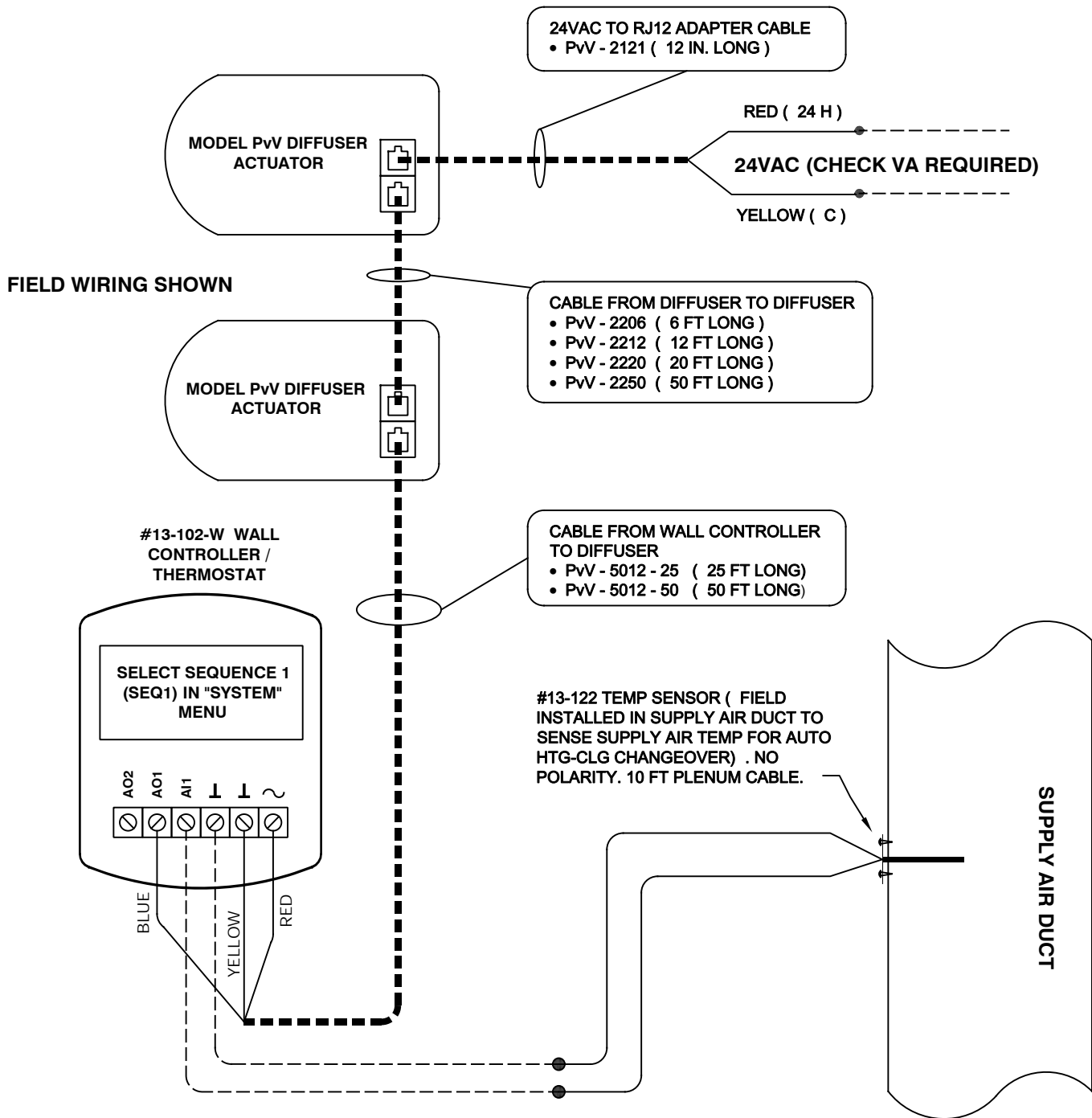

**NOTES:**

- 24VAC SOURCE, DIFFUSERS, & WALL SENSOR CAN BE INTERCONNECTED IN SERIES, PARALLEL, OR BOTH .
- THE # OF DIFFUSERS CONTROLLED BY A SINGLE WALL SENSOR IS DETERMINED BY CABLE LENGTHS.

**JOB NAME:**  
**SUBMITTED BY:**  
**DATE:**

**DWG #:** PVV-A02.1  
**REV:** B  
**DATE:** 8-29-18

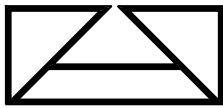

- AUTO HTG-CLG CHANGEOVER
- VAV HEATING & COOLING
- PRESSURE DEPENDENT
- ANALOG ELECTRONIC CONTROLS
- AIR FLOW SETPOINTS ADJUSTED AT THERMOSTAT

### COOLING MODE

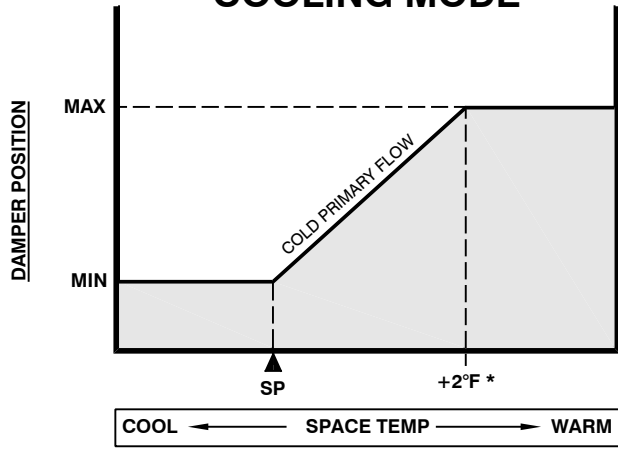

\* PROPORTIONAL BAND (PROP BD) DEFAULT AT 2°F, ADJUSTABLE FROM 1 to 10°F IN 'ADVANCE' MENU ON THERMOSTAT

### HEATING MODE

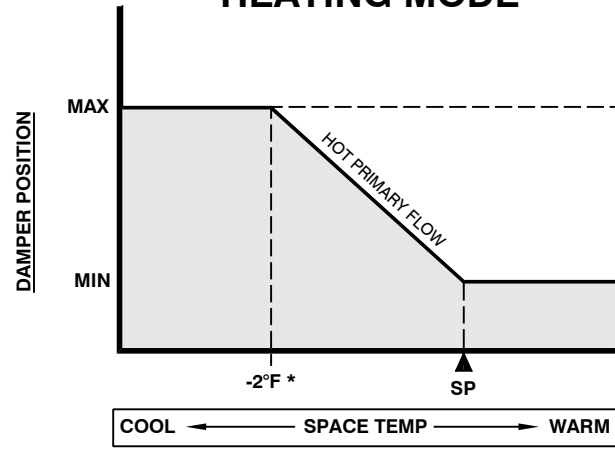

\* PROPORTIONAL BAND (PROP BD) DEFAULT AT 2°F, ADJUSTABLE FROM 1 to 10°F IN 'ADVANCE' MENU ON THERMOSTAT

## SEQUENCE OF OPERATION

THE WALL CONTROLLER / T'STAT SIGNALS THE DIFFUSER ACTUATOR IN RESPONSE TO THE SPACE TEMPERATURE. THE CONTROLS SENSE SUPPLY AIR TEMP AND AUTOMATICALLY INDEX TO D.A. COOLING OR R.A. HEATING MODE. NOTE UPON INITIAL POWER UP, THE DIFFUSER ACTUATOR WILL PERFORM A SELF-CALIBRATION ROUTINE. WHEN USER ADJUSTS WALL CONTROLLER FOR DAMPER POSITION ( MIN AND MAX FLOW RATES) , AO1 MIN AND AO1 MAX ARE SET BETWEEN 2VDC ( DAMPER CLOSED) AND 10VDC ( 100% DAMPER OPEN) .

### COOLING MODE

1. WHEN SUPPLY AIR TEMP IS LESS THAN 77°F, THE THERMOSTAT D.A. COOLING OUTPUT CONTROLS FLOW ( COOLING MODE) . WITH SPACE TEMPERATURE BELOW THE THERMOSTAT SETPOINT, MINIMUM DAMPER POSITION IS MAINTAINED AS SET BY VOLTAGE FOR AO1 MIN.
2. AS THE SPACE TEMPERATURE INCREASES FROM SETPOINT TO 2°F ABOVE SETPOINT, THE DAMPER OPENS FROM MINIMUM POSITION ( AO1 MIN) TO MAXIMUM POSITION ( AO1 MAX) . AT OVER 2°F ABOVE SETPOINT, MAXIMUM DAMPER POSITION IS MAINTAINED.

### HEATING MODE

1. WHEN SUPPLY AIR TEMP IS GREATER THAN 77°F, THE THERMOSTAT R.A. HEATING OUTPUT CONTROLS DAMPER POSITION ( HEATING MODE) . WITH SPACE TEMPERATURE ABOVE THE T'STAT SETPOINT, MINIMUM DAMPER POSITION IS MAINTAINED AS SET BY VOLTAGE AO1 MIN.
2. AS THE SPACE TEMPERATURE DECREASES FROM HEATING SETPOINT TO 2°F BELOW THE SETPOINT, THE DAMPER OPENS FROM MINIMUM POSITION ( AO1 MIN) TO MAXIMUM POSITION ( AO1 MAX) . AT OVER 2°F BELOW THE SETPOINT, MAXIMUM DAMPER POSITION IS MAINTAINED.

REFER TO WALL CONTROLLER INSTRUCTIONS FOR ACCESS TO MENUS AND SETTINGS. AO1 MIN AND MAX CONTROL THE DAMPER POSITION AND UNITS ARE VDC. ADJUST CHANGEOVER TEMP AS APPLICABLE. UPON LOSS OF POWER, DAMPER FAILS IN PLACE. THE DUCT TEMP SENSOR MUST BE IN AN AIR STREAM THAT INDICATES HEATING OR COOLING. DIFFUSER MIN DAMPER POSITION MUST ALLOW AIR FLOW TO PROPERLY SENSE CHANGEOVER CONDITIONS.

JOB NAME:  
SUBMITTED BY:  
DATE:

DWG #: PVV - A02.2  
REV: A  
DATE: 8-29-18