

ANEMOSTAT[®]

DIGITAL VAV DIFFUSERS

Control Package

PvV - D02

- AUTO HTG-CLG CHANGEOVER
- VAV HEATING & COOLING
- PRESSURE DEPENDENT
- DIRECT DIGITAL ROOM CONTROLLER (BACnet MSTP)
- AIR FLOW SETPOINTS ADJUSTED AT THERMOSTAT

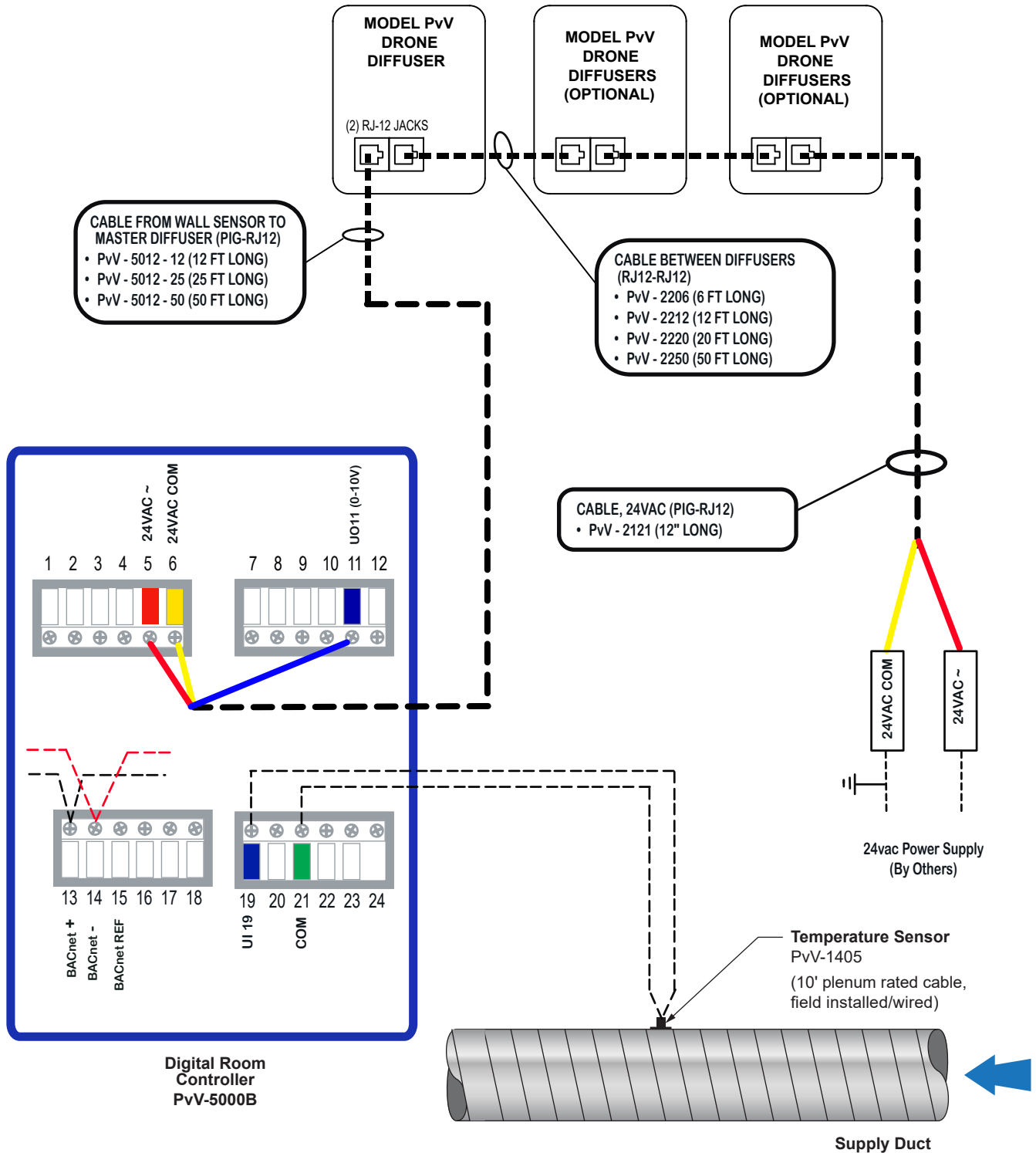

JOB NAME:
SUBMITTED BY:
DATE:

DWG #: PVV-D02.1
REV: -
DATE: 05.11.21

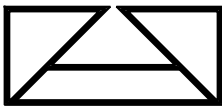

- AUTO HTG-CLG CHANGEOVER
- DIRECT DIGITAL ROOM CONTROLLER (BACnet MSTP)
- VAV HEATING & COOLING
- AIR FLOW SETPOINTS ADJUSTED AT THERMOSTAT
- PRESSURE DEPENDENT

COOLING MODE

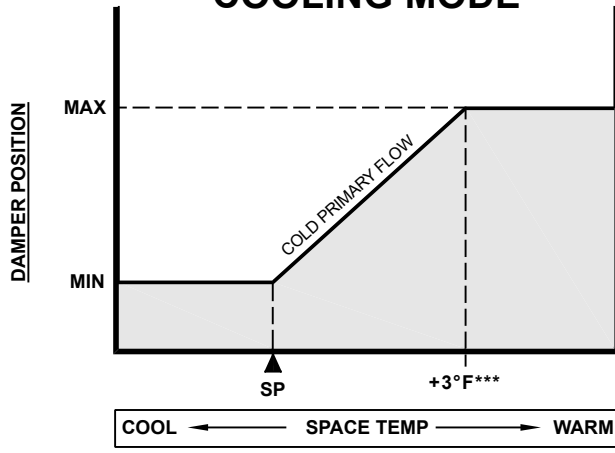

*** PROPORTIONAL BAND (PROP BD) DEFAULT AT 3°F, ADJUSTABLE FROM 1 to 10°F IN "ADVANCE" MENU ON THERMOSTAT

HEATING MODE

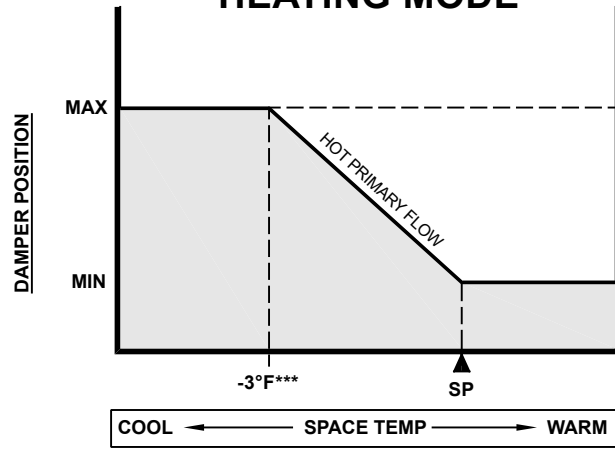

*** PROPORTIONAL BAND (PROP BD) DEFAULT AT 3°F, ADJUSTABLE FROM 1 to 10°F IN "ADVANCE" MENU ON THERMOSTAT

SEQUENCE OF OPERATION

The room controller / thermostat signals the diffuser actuator in response to the space temperature. The controls sense the supply air temperature via the duct temperature sensor and automatically index to D.A. Cooling or R.A. Heating mode. Note upon initial power up, the diffuser actuator will perform a self-calibration routine. When the user adjusts the wall controller for damper position (Min and Max flow rates), 0% represents a fully closed damper (2vdc) and 100% represents a fully open damper (10vdc) on the diffuser.

COOLING MODE

1. When the supply air temperature is less than the changeover temperature setpoint, the room controller is in the D.A. Cooling mode. With the space temperature below the cooling setpoint, the minimum damper position is maintained as set by the % Minimum Damper position.
2. As the space temperature increases from setpoint to 3° above setpoint, the damper opens from minimum position (% Min) to maximum cooling position (% Max). At >3° above setpoint, maximum damper position is maintained.

HEATING MODE

1. When the supply air temperature is greater than the changeover temperature setpoint, the room controller is in the R.A. Heating mode. With the space temperature above the heating setpoint, the minimum damper position is maintained as set by the % Minimum Damper position.
2. As the space temperature decreased from setpoint to 3° below setpoint, the damper opens from minimum position (% Min) to maximum heating position (% Max). At <3° below setpoint, maximum damper position is maintained.

Refer to the PvV IOM manual for installation and room controller setup and configuration.

JOB NAME:
SUBMITTED BY:
DATE:

DWG #: PVV - D02.2
REV: A
DATE: 05.17.21