

ANEMOSTAT[®]

AIR TERMINAL CONTROLS

Control Package
SD - A - 5291

- SINGLE DUCT
- ANALOG ELECTRONIC CONTROLS
- DUCT STATIC PRESSURE CONTROL AFTER DAMPER
- MAINTAIN CONSTANT STATIC PRESSURE (0 - 2")

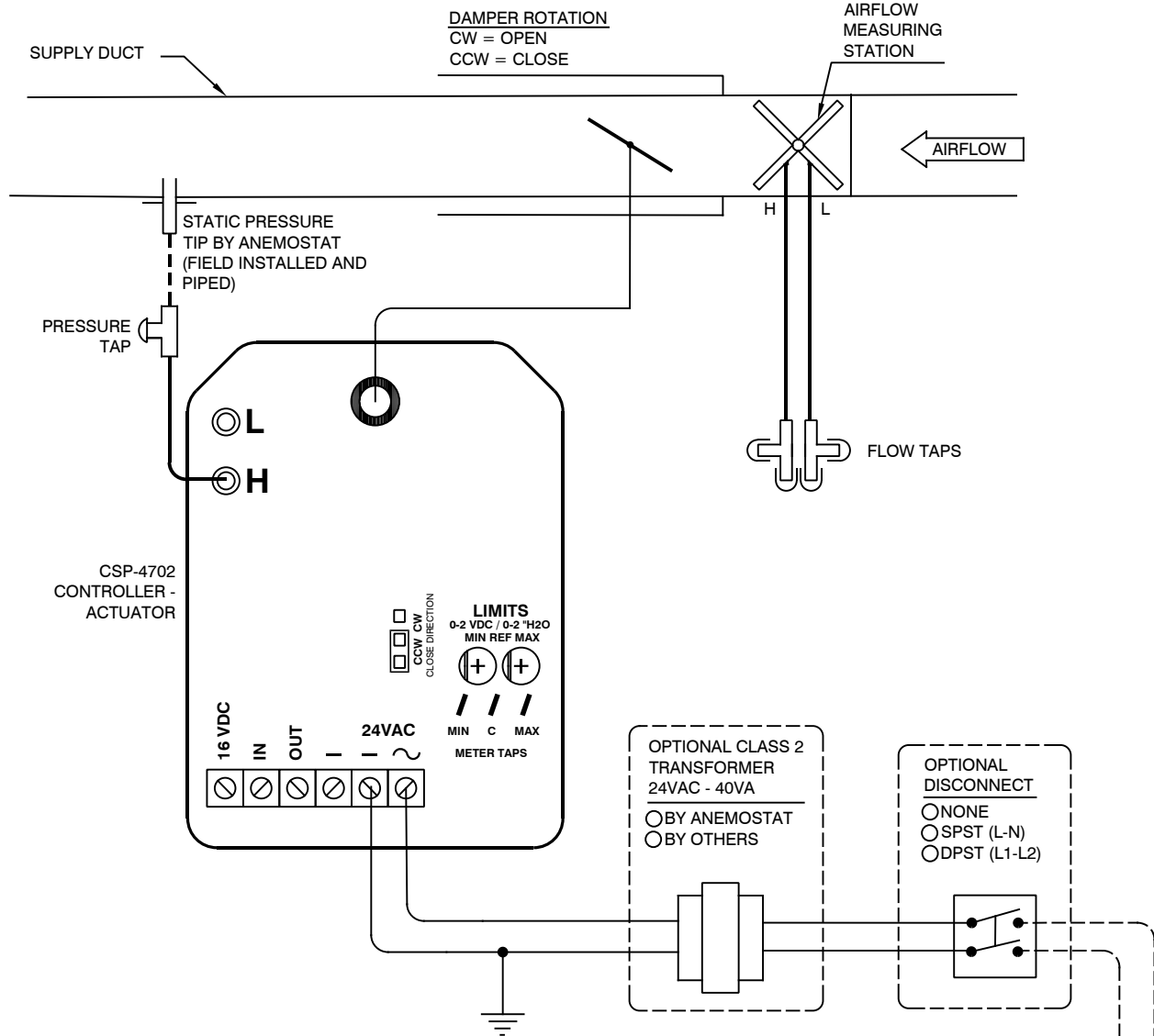

- FACTORY WIRING
- - - - - FIELD WIRING
- FACTORY PIPING
- - - - - FIELD PIPING

ADJUSTMENT PROCEDURE:

1. CONNECT THE "HI" PORT OF THE CSP-4702 TO THE PITOT TUBES OR SSS-1000 SERIES SENSORS.
2. CONNECT THE 24 VAC POWER. OPTIONALLY CONNECT REMOTE SETPOINT AND PRESSURE READING DEVICES TO A BUILDING AUTOMATION SYSTEM CONTROLLER.
3. SET THE MIN FLOW LIMIT TO THE DESIRED BYPASS PRESSURE SETPOINT. FACTORY DEFAULT IS 0 VDC = 0" WC.
4. KEEP THE ROTATION DIRECTION TO CCW FOR THE "CLOSE DIRECTION"

PRIMARY VOLTAGE, 1Ø			
120 V	<input type="radio"/> 208 V	<input type="radio"/> 240 V	<input type="radio"/> 277 V
N	L2	L2	N
L	L1	L1	L
GROUND			

REFER TO ANEMOSTAT "CONTROLS MANUAL" (CM-1) FOR ADJUSTMENT & TROUBLESHOOTING PROCEDURES.

JOB NAME:
SUBMITTED BY:
DATE:

DWG #: SD-A-5291
REV: -
DATE: 11-21-17