

### APPLICATION

- Parallel type, fan assisted air terminal
- Maintain space temperature with primary flow control and intermittent fan operation for energy reclamation from warmer ceiling plenum during heating cycles.
- Control strategies using pneumatic, analog, or direct digital control (DDC) systems

### FEATURES

- Efficient, 3 Speed motor (permanent split capacitor) with thermal overload protection allows horsepower change for greatest potential of energy savings. 120 or 277 vac, 1ø
- Solid state speed controller with factory calibrated minimum voltage setting for precision air flow adjustment.
- 18 & 20 gauge zinc-coated steel design for rigidity.
- 1" dual density thermal / acoustic internal insulation (NFPA 90A & UL 181)
- Easy to install and service – all controls located in one convenient location for single point electrical connection.
- Swing-down fan access panel
- Steel control enclosure, screw attached cover. Left hand position is standard.
- 90° inlet damper & perimeter seal limiting leakage to <1% of max rated flow at 3" w.g. inlet static pressure.
- Patented Velocity Wing primary flow sensor measures flow to ±5% accuracy regardless of inlet conditions. Highest velocity pressure amplification means high turn down with high accuracy.
- AHRI 880 certified performance / ETL listed (UL 1995).
- Accepts flanged discharge duct connection



### OPTIONS & ACCESSORIES

- Q5 radiated sound elbow
- Hinged front control enclosure cover
- Internal Insulation - 1/2" or 1" foil-faced glass fiber insulation with metal taped edges meeting ASTM C665, double wall construction, Lo-Temp casing construction, 3/8" fiber free closed cell foam insulation, no insulation, see page A-11.
- Slip & drive cleat discharge collar
- 1" Throw-away filter & filter rack
- Unit mounting brackets (field installed)
- Electrical component options – line voltage disconnect switch, power fusing, 3-speed manual motor selector switch, electric damper actuator (24vac) for use with DDC controls, fan relay for on-off function, 24vac step down transformer
- Digital, analog, or pneumatic control systems

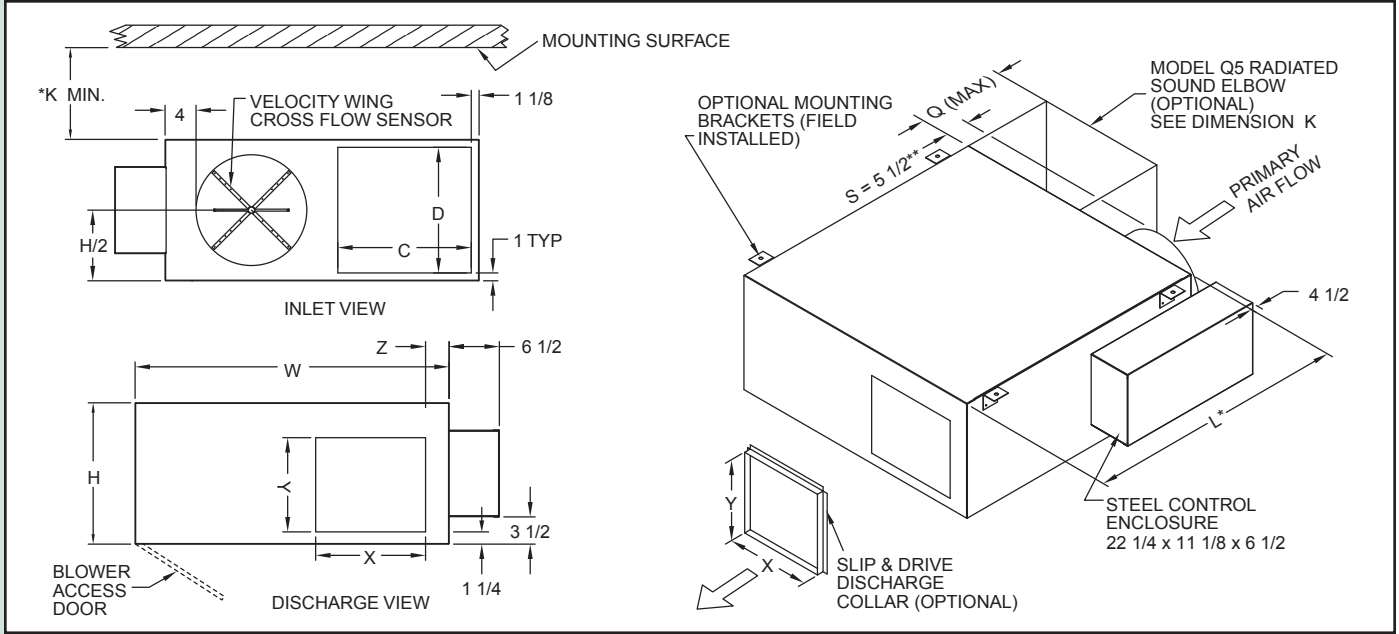

Model Number QPTE	Cabinet Size	Motor H.P.	Nominal Inlet Diameter	Height H	Width W	Length L	Min. K	Discharge		Z	Induction			Weight LB
								X	Y		C	D	Q	
11706, 11707, 11708, 11709	1	1/6	6, 7, 8, 9	15	34	30	6	11-1/2	11	3	13	12	18	83
12506, 12507, 12508, 12509	1	1/4	6, 7, 8, 9	15	34	30	6	11-1/2	11	3	13	12	18	86
21709, 21710, 21712	2	1/6	9, 10, 12	18	40	34	6	14	12	3	17	16	18	100
22509, 22510, 22512	2	1/4	9, 10, 12	18	40	34	6	14	12	3	17	16	18	105
25009, 25010, 25012	2	1/2	9, 10, 12	18	40	34	6	14	12	3	17	16	18	110
35012, 35014, 35016	3	1/2	12, 14, 16	20	46	40	8	19	16	2-1/4	21	18	20	134
37512, 37514, 37516	3	3/4	12, 14, 16	20	46	40	8	19	16	2-1/4	21	18	20	139
31012, 31014, 31016	3	1	12, 14, 16	20	46	40	8	19	16	2-1/4	21	18	20	146