

PRODUCT FEATURES

- Adjustable volume and pattern controllers
- Mounting brackets and screws provided (field installed)

CONSTRUCTION FEATURES

- Material:**
Extruded aluminum
- Finish:**
- Arctic White (Black Pattern/Volume Controllers)
 - Natural Anodize (Black Pattern/Volume Controllers)
 - Custom Color : _____

SUPPLY MODELS

- SLAD-FL-50** 1/2" Slot Width (1-4 slots)
- SLAD-FL-75** 3/4" Slot Width (1-4 slots)
- SLAD-FL-100** 1" Slot Width (1-4 slots)
- SLAD-FL-150** 1-1/2" Slot Width (1-4 slots)

RETURN MODELS (No Internal Controllers)

- SLAR-FL-50** 1/2" Slot Width (1-4 slots)
- SLAR-FL-75** 3/4" Slot Width (1-4 slots)
- SLAR-FL-100** 1" Slot Width (1-4 slots)
- SLAR-FL-150** 1-1/2" Slot Width (1-4 slots)

OPTIONS

- LEC** Linear Egg Crate
- LED** Linear Equalizing Deflector
- AD** Plenum

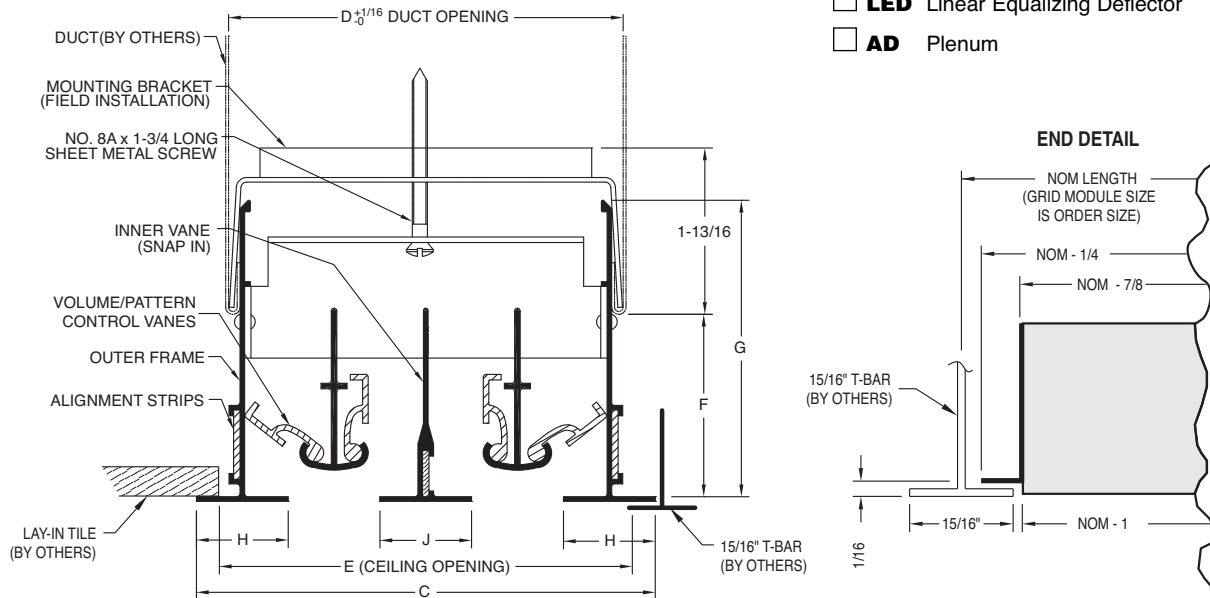

| SLAD-FL-50 • 1/2" SLOT WIDTH | | | | | | | |
|------------------------------|-------|---------|-------|-----|----------------|---------|-------|
| # SLOTS | C | D | E | J | F | G | H |
| 1 | 2-3/4 | 1-9/16 | 2 | - | 1-5/8 to 1-7/8 | 2-15/16 | 1-1/8 |
| 2 | 4 | 2-13/16 | 3-1/4 | 3/4 | 1-5/8 to 2-3/8 | | |
| 3 | 5-1/4 | 4-1/16 | 4-1/2 | 3/4 | | | |
| 4 | 6-1/2 | 5-5/16 | 5-3/4 | 3/4 | | | |

| SLAD-FL-75 • 3/4" SLOT WIDTH | | | | | | | |
|------------------------------|-------|---------|-------|-----|----------------|---------|-------|
| # SLOTS | C | D | E | J | F | G | H |
| 1 | 3 | 1-13/16 | 2-1/4 | - | 1-5/8 to 2-3/8 | 2-15/16 | 1-1/8 |
| 2 | 4-1/2 | 3-5/16 | 3-3/4 | 3/4 | | | |
| 3 | 6 | 4-13/16 | 5-1/4 | 3/4 | | | |
| 4 | 7-1/2 | 6-5/16 | 6-3/4 | 3/4 | | | |

| SLAD-FL-100 • 1" SLOT WIDTH | | | | | | | |
|-----------------------------|-------|--------|-------|---|------------|--------|-------|
| # SLOTS | C | D | E | J | F | G | H |
| 1 | 3-1/2 | 2-5/16 | 2-1/2 | - | 2 to 2-3/4 | 3-9/32 | 1-1/4 |
| 2 | 5-1/2 | 4-5/16 | 4-1/2 | 1 | | | |
| 3 | 7-1/2 | 6-5/16 | 6-1/2 | 1 | | | |
| 4 | 9-1/2 | 8-5/16 | 8-1/2 | 1 | | | |

| SLAD-FL-150 • 1-1/2" SLOT WIDTH | | | | | | | |
|---------------------------------|--------|---------|--------|-------|----------------|--------|---------|
| # SLOTS | C | D | E | J | F | G | H |
| 1 | 5-1/8 | 3-5/16 | 3-3/4 | - | 2-7/8 to 3-5/8 | 4-5/32 | 1-13/16 |
| 2 | 8-1/8 | 6-5/16 | 6-3/4 | 1-1/2 | | | |
| 3 | 11-1/8 | 9-5/16 | 9-3/4 | 1-1/2 | | | |
| 4 | 14-1/8 | 12-5/16 | 12-3/4 | 1-1/2 | | | |

All dimensions are in inches.

JOB NAME:

SUBMITTED BY: