

Anemostat® SUBMITTAL

1220 Watson Center Road • Carson, CA 90745-4206
(310) 835-7500 • FAX (310) 835-0448
air@anemostat.com • www.anemostat.com

Model **SLAD**
MITERED CORNERS
STACK MITER
(INSIDE)

DIFFUSERS

PRODUCT FEATURES

- Welded corner with standard 90° stack miter
- Available to match any SLAD mounting frame style, slot quantity, slot width
- Retains same appearance as adjoining units

CONSTRUCTION DETAILS

- Material:** Extruded Aluminum
(same as SLAD diffusers and returns)
- Finish:** Arctic white outer flanges and center tees (**std**)
Flat black anchors (**std**)
- Custom Colors (opt)

ACCESSORIES

- Blank-off plate (factory installed)
coated steel

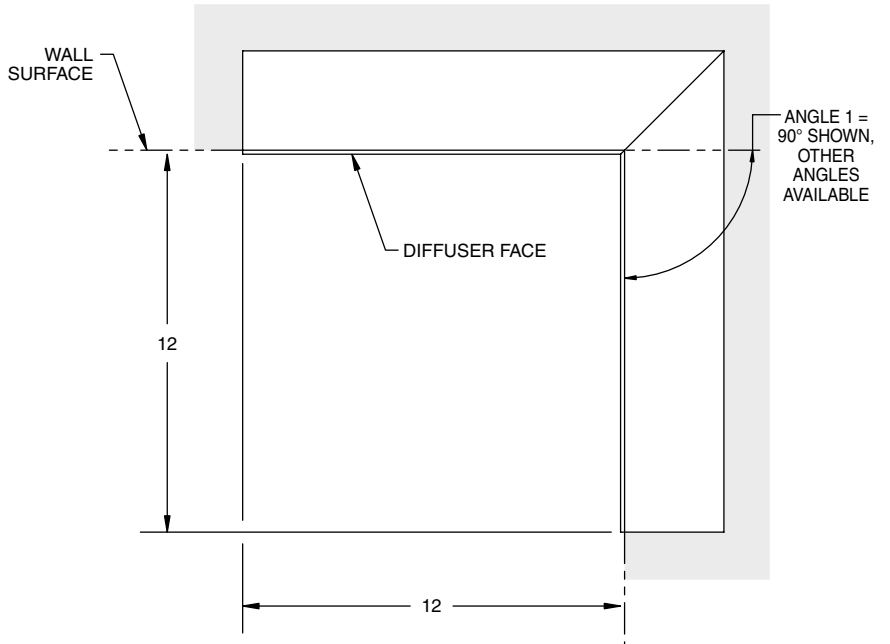
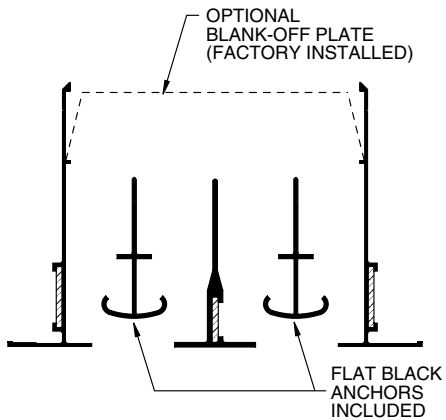
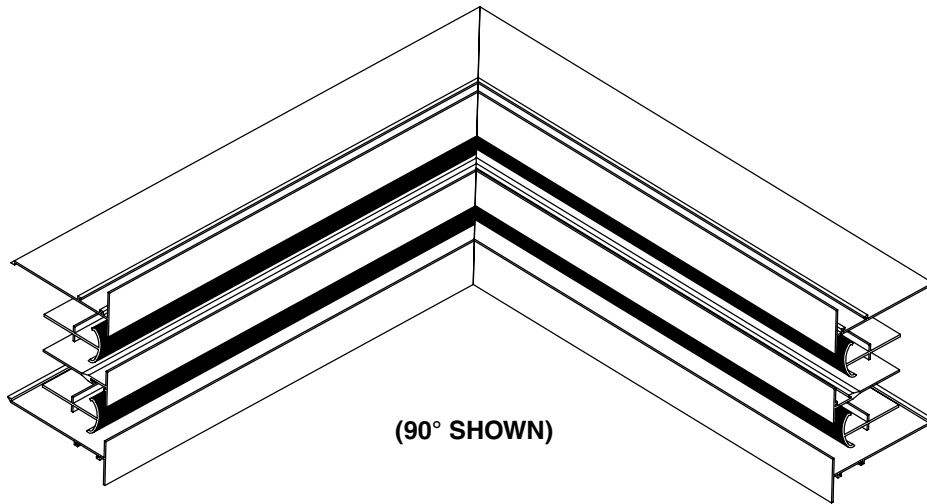

- REFER TO SLAD SUBMITTAL DETAIL FOR CROSS SECTION DIMENSIONS
- 2 SLOT SHOWN

All dimensions are in inches.

JOB NAME:

SUBMITTED BY: