

Model **SCR-D-D**
PLENUM SLOT
DUCTED RETURN
9/16" NARROW SLOT

PRODUCT FEATURES

- 1,2,3, or 4 parallel slots integrated into a coated steel supply plenum
- 3/4", 1", 1-1/2" slot widths
- 24", 36", 48", 60" nominal lengths (custom lengths available)

CONSTRUCTION DETAILS

- Material:** 24 GA Zinc-Coated Steel
Finish: Flat black on exposed Diffuser Face surfaces (**std**)
Factory attached T-Bars are white
- Custom Colors (opt)

MODELS

- SCR-D-D** All center Tees included
- SCR-D-D-N** 2' x 2' Crossover, All center Tees included (notch in center of 4' plenum)
- SCR-D-DX** Straddle (2 slot only - NO center Tee). Unit includes notched end caps for grid member.
- SCR-D-DX-N** Combination Crossover and Straddle feature (2 slot only)

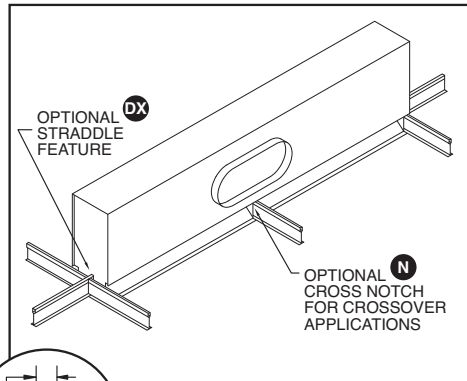
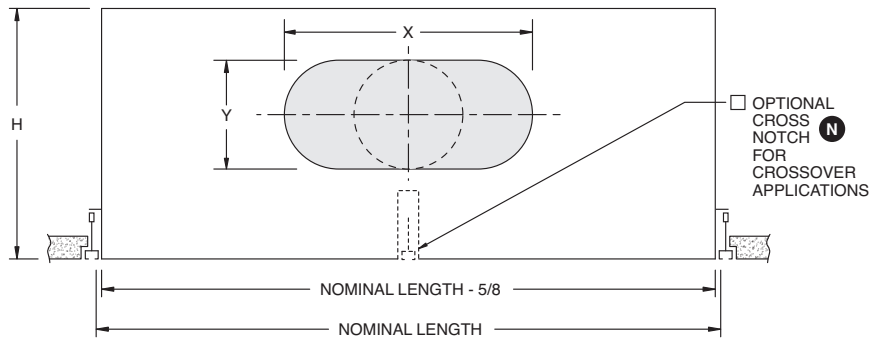
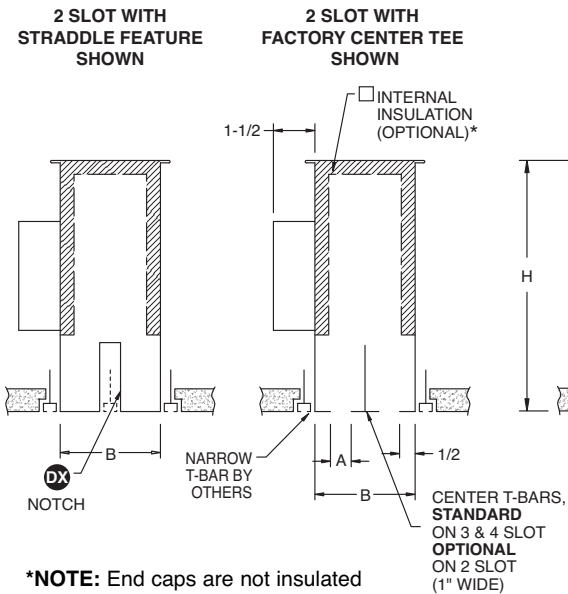

	SLOT WIDTH A	B				NOM LENGTH	
		1-SLOT	2-SLOT (Center T)	2-SLOT (DX Straddle)	3-SLOT		4-SLOT
SCD-75	3/4"	1-3/4	3-1/2	4-1/8	5-1/4	7	24, 30, 36, 48, 60
SCD-10	1"	2	4	4-5/8	6	8	
SCD-15	1-1/2"	2-1/2"	5	5-5/8	7-1/2	10	

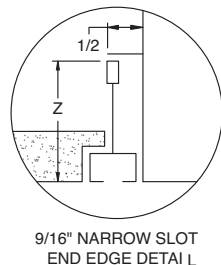
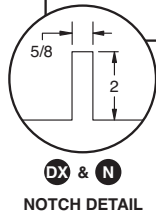

	Inlet Size	X	Y	H
1 & 2 SLOT	5" Ø	4-7/8	4-7/8	8
	6" Oval	6-13/32	4-7/8	8
	8" Oval	9-19/32	4-7/8	8
	10" Oval	12-23/32	4-7/8	8
3 & 4 SLOT	12" Oval	14-5/32	7-7/8	11
	5" Ø	4-7/8	4-7/8	11
	6" Ø	5-7/8	5-7/8	11
	8" Ø	7-7/8	7-7/8	11
	10" Oval	11	7-7/8	11
	12" Oval	14-5/32	7-7/8	11

All dimensions are in inches.

JOB NAME:

SUBMITTED BY:

FACTORY INSTALLED SIDE TEES / CLIPS
(FACTORY TEES ARE 1" WIDE - WHITE FINISH)

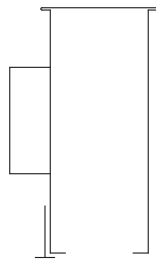

OPTION 1
ONE SIDE TEE
(INLET SIDE)

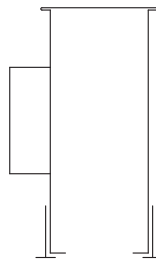

OPTION 2
TWO SIDE TEE

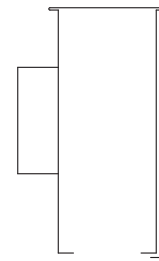

OPTION 3
ONE SIDE TEE
(NON-INLET SIDE)

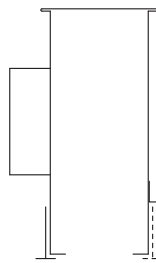

OPTION A
ONE SIDE TEE
(INLET SIDE)
+ T-BAR CLIPS

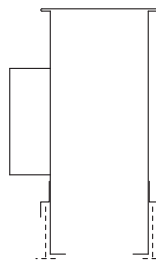

OPTION B
T-BAR CLIPS
(BOTH SIDES)

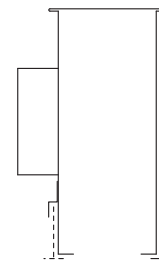

OPTION C
ONE SIDE TEE
(NON-INLET SIDE)
+ T-BAR CLIPS

GRID / CEILING TYPE

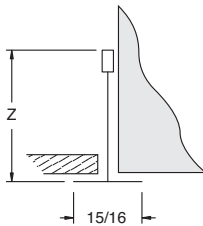

15/16" LAY-IN

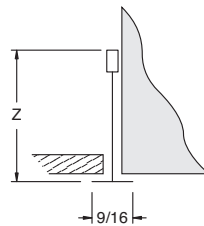

9/16" LAY-IN

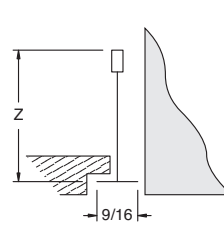

9/16" TEGULAR

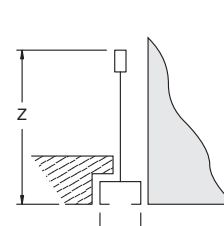

9/16" NARROW SLOT

CEILING MANUFACTURER: _____

Z = _____

MODEL: _____

All dimensions are in inches.

JOB NAME: _____

SUBMITTED BY: _____