



# Anemostat®

## AIR DISTRIBUTION

# SUBMITTAL SHEET

www.anemostat-hvac.com



Model E 30 - N1

**ENHANCED CAPACITY  
FIXED BLADE RETURN**

**Steel / Stainless Steel**

LAY-IN T-BAR

40° DEFLECTION

### PRODUCT FEATURES

- 3/4" (19) Louver spacing
- Registers include a factory attached opposed blade volume control damper

### CONSTRUCTION DETAILS

#### Material:

- Steel
- Stainless Steel

#### Finish:

- Arctic White (Std)
- Satin Polish (Stn Stl Only)
- Custom Color Match

#### Accessories

- O B - 1 - ST Opposed Blade Damper (Steel)
- O B - 1 - AL Opposed Blade Damper (Aluminum)
- O B - 1 - 04 Opposed Blade Damper (Stn Steel)

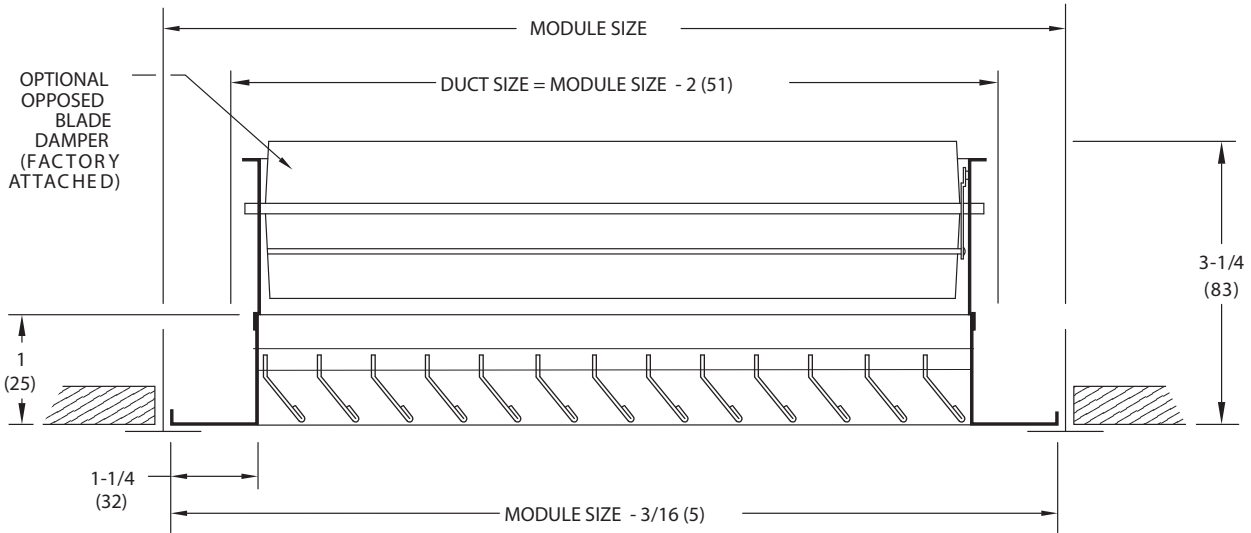

SHORT BLADES (S)

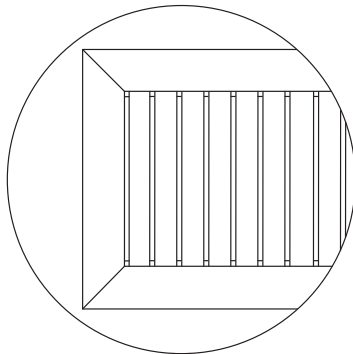

LONG BLADES (L)

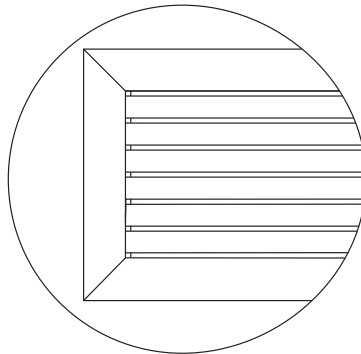

LAY-IN T-BAR MODULE SIZES	NOMINAL NECK SIZE
12 X 12 (305 X 305)	10 X 10 (254 X 254)
12 X 24 (305 X 610)	10 X 22 (254 X 559)
24 X 24 (610 X 610)	22 X 22 (559 X 559)
24 X 48 (610 X 1219)	22 X 46 (559 X 1168)

Available for ANY module size.

Dimensions in ( ) are millimeters

All dimensions are in inches.

JOB NAME:

SUBMITTED BY: