



Anemostat[®]

SUBMITTAL

1220 Watson Center Road • Carson, CA 90745-4206
 (310) 835-7500 • FAX (310) 835-0448
 air@anemostat.com • www.anemostat-hvac.com

Model **QC-C-RT**

MODULAR CORE

ROTO-THROW DIFFUSER

WITH EXTENSION PANEL

CONCEALED SPLINE

GRID SYSTEM

CUSTOM DIFFUSERS

PRODUCT FEATURES

- Flexible, modular core supply diffuser for horizontal air distribution patterns.
- Diffuser with (4) Cores easily re-configured in field for desired air distribution pattern (1, 2, 3 or 4-way)
- Spring loaded cores

Note: Diffuser ships with 4-way pattern

CONSTRUCTION DETAILS

Diffuser:

- Steel
- Aluminum

Extension Panel:

- Steel
- Aluminum

Finish:

- Arctic White Baked Finish
- Custom Colors

MODELS

- QC-C-RT** (Concealed Spline Grid System)

ACCESSORIES

- OB1-ST** (Steel Opposed Blade Volume Control Damper)
- OB1-AL** (Aluminum Opposed Blade Volume Control Damper)
- SRA** Square to Round Adapter, Steel
- VD** Volume Damper, Butterfly Type, Steel (used with SRA)

← GRID MODULE SIZE - 1/4 →

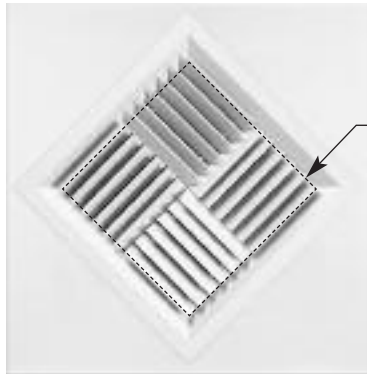

DUCT ORIENTATION

AVAILABLE DUCT SIZES	OPTIONAL SRA MAX Ø
6 x 6	6" Ø
8 x 8	8" Ø
10 x 10	10" Ø
12 x 12	12" Ø

GRID MODULE SIZE	MAX NECK SIZE
24 x 24	12 x 12

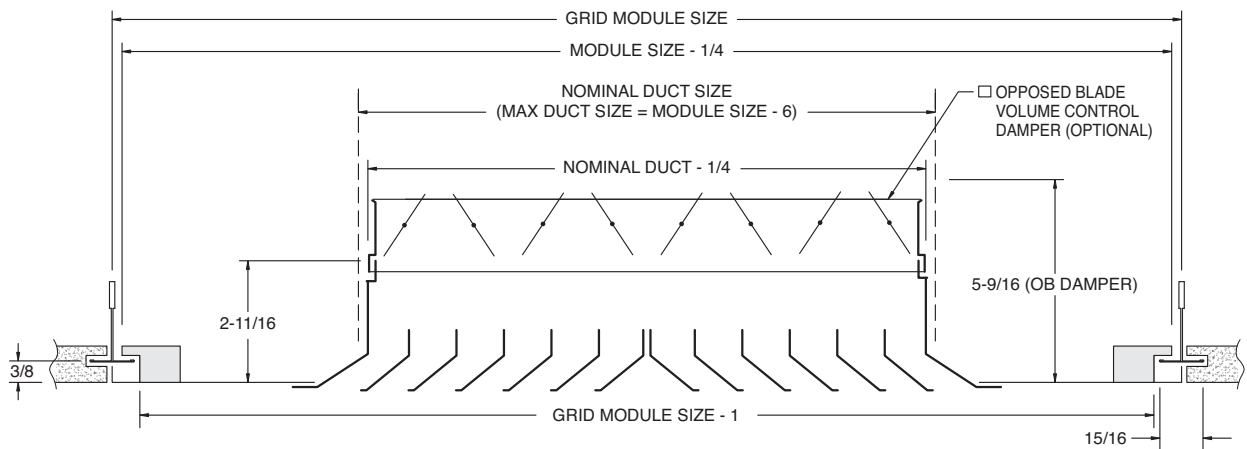

CORE PATTERNS

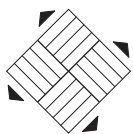

4-way

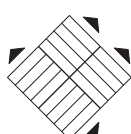

3-way

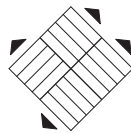

3-way

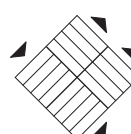

2-way corner

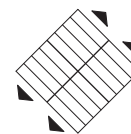

2-way opposite

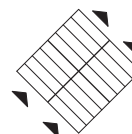

1-way

All dimensions are in inches.

JOB NAME:

SUBMITTED BY: