

**PRODUCT FEATURES**

- Optional volume control damper, accessible from room side
- Removable inner plaque assembly
- Optional blankoff baffles, field installed

**CONSTRUCTION DETAILS**

- Material:** Cold Rolled Steel (**std**)
- Aluminum (opt)
  - 304 Stainless Steel (opt)
- Finish:** White (**std**)
- Black
  - Custom Colors (opt)

**MODELS**

- PHV-D** 9/16" Narrow Slot
- PHV-L** Lay-In T-Bar
- PHV-F** Surface Mount
- PHV-H** Metal Pan (Snap-In)
- PHV-T** 15/16" Tegular

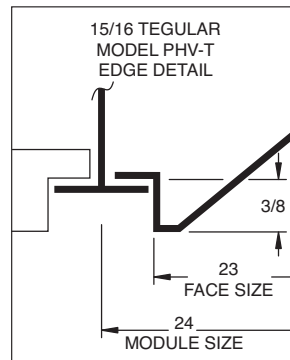
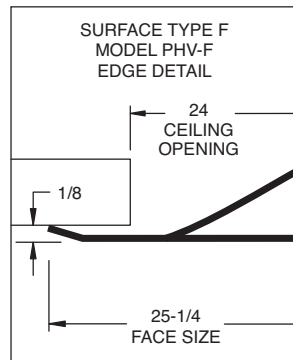
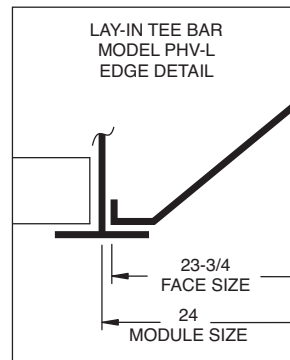
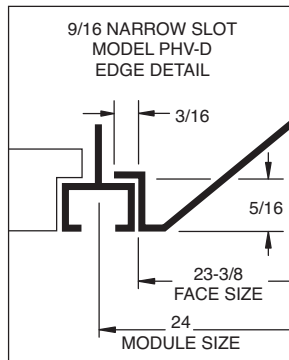
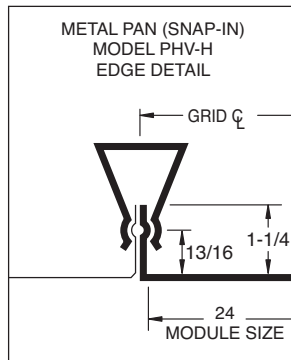
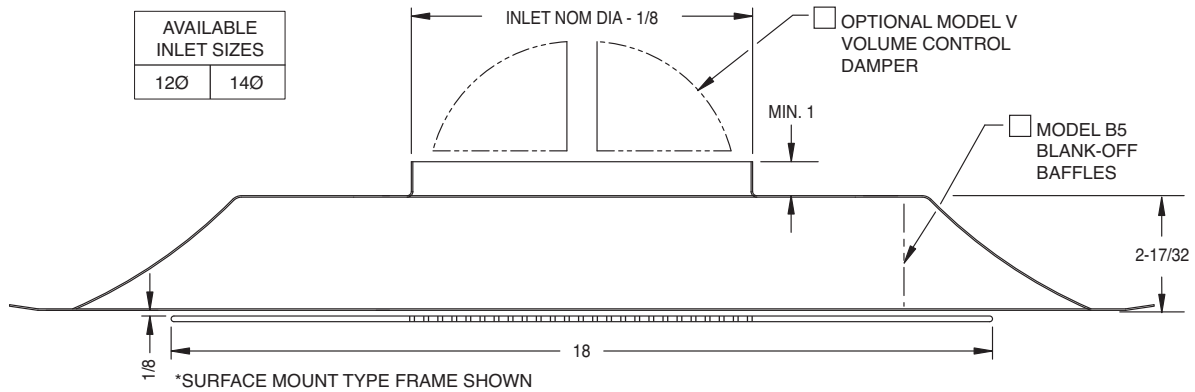

All dimensions are in inches.

JOB NAME:

SUBMITTED BY: