



Anemostat®
AIR DISTRIBUTION

MODEL **SL27**

EXTRUDED ALUMINUM LOUVERS
4" DEEP

SIGHTPROOF

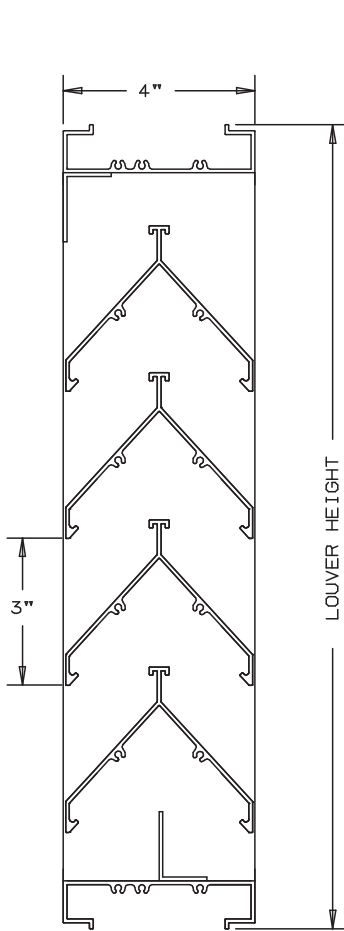

NOT TO SCALE

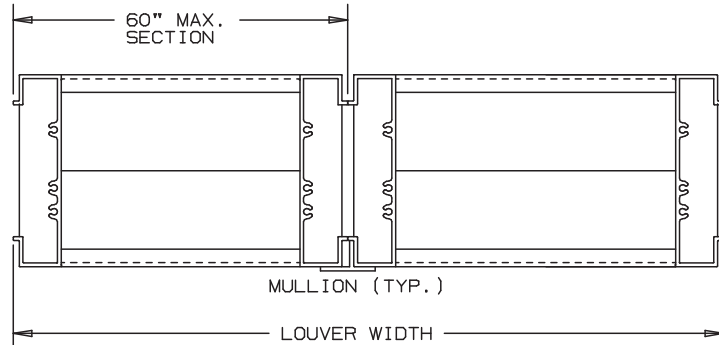

SPECIFICATIONS

MATERIAL: EXTRUDED ALUMINUM 6063-T6/T52 ALLOY
.081" THK.

FACE OF LOUVER: ALL SURFACES ARE FLUSH. WITH JAMBS
CONTAINED WITHIN THE HEAD AND SILL.

SCREEN: (WHEN INDICATED)

- BIRD SCREEN - 1/2" FLATTENED ALUMINUM, .051" THK.
- OR - 1/2" SQ. MESH INTERMEDIATE DOUBLE-CRIMPED ALUMINUM WIRE, .063" DIA.
- OR - 18/16 MESH, .011" DIA. ALUMINUM WIRE INSECT SCREEN.

FINISH: _____

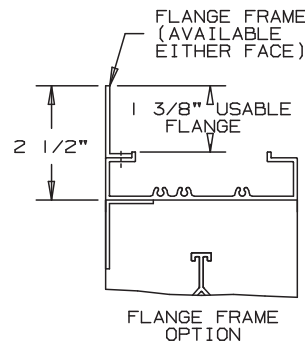

NOMINAL DEDUCTIONS WILL BE MADE TO OPENING SIZES GIVEN.

ITEM	QTY.	WIDTH	HEIGHT	WIDTH	HEIGHT	MULL	TYPE	LOC	
		OPENING SIZE		LOUVER SIZE					

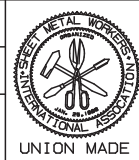

Anemostat Air Distribution
1220 E. Watson Center Road
Carson, CA 90745
310-835-7500 • air@anemostat.com
www.anemostat-hvac.com

AGENT: _____

ARCH./ENG. : _____

CONTR. : _____

PROJECT : _____

EDR : _____ ECN : _____ JOB : _____

DATE : _____ DWN. : _____ DWG. : _____

MODEL SL27

SIGHTPROOF

EXTRUDED ALUMINUM - STATIONARY

PERFORMANCE DATA

RATINGS DO NOT INCLUDE THE EFFECT OF BIRDSCREEN.

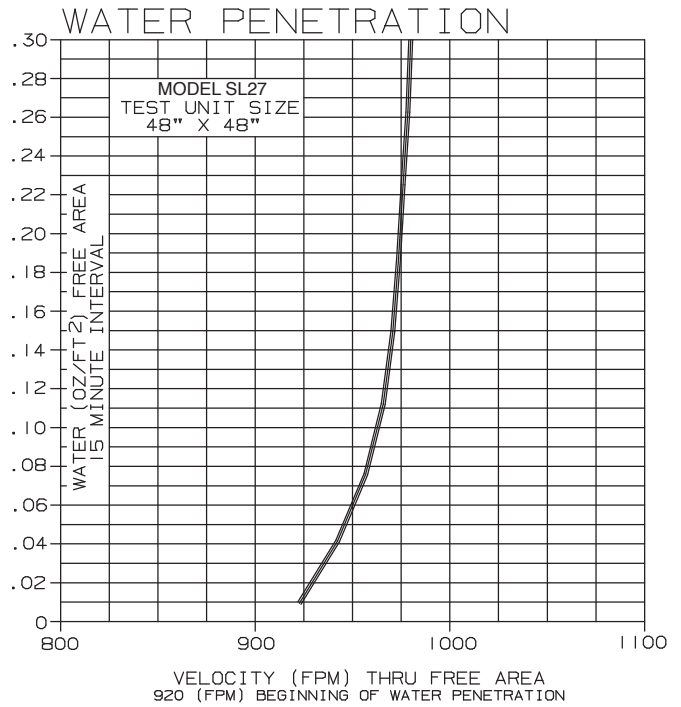
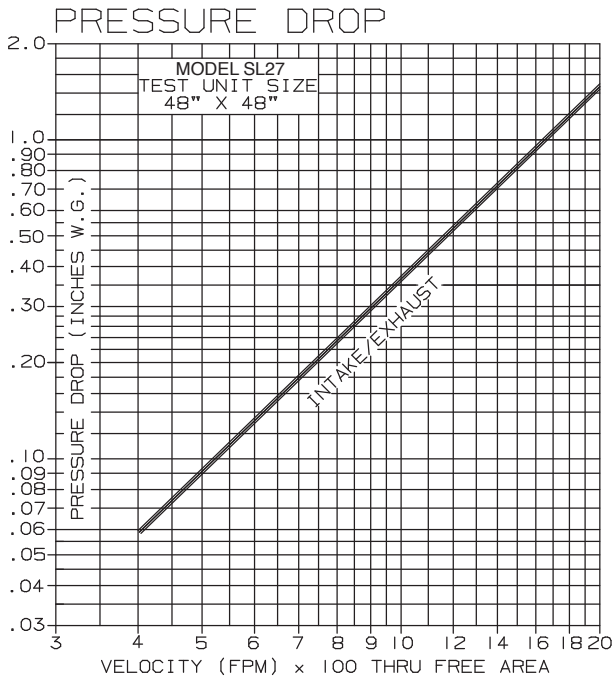

FREE AREA

		FREE AREA (SQ. FT.)								
		WIDTH								
HEIGHT		12"	18"	24"	30"	36"	42"	48"	54"	60"
		12"	.26	.39	.52	.65	.77	.90	1.03	1.16
	24"	.67	1.01	1.34	1.68	2.01	2.35	2.68	3.02	3.35
	36"	1.08	1.62	2.17	2.71	3.25	3.79	4.33	4.87	5.41
	48"	1.50	2.24	2.99	3.74	4.49	5.23	5.98	6.73	7.48
	60"	1.91	2.86	3.81	4.77	5.72	6.68	7.63	8.58	9.54
	72"	2.32	3.48	4.64	5.80	6.96	8.12	9.28	10.44	11.60
	84"	2.73	4.10	5.46	6.83	8.20	9.56	10.93	12.29	13.66
	96"	3.14	4.72	6.29	7.86	9.43	11.00	12.58	14.15	15.72