

SUBMITTAL SHEET

www.anemostat-hvac.com

B.S.-476.22
British Standard
BSEN-1634-1
Fire Resistance

FIRE
RATINGS



UNDERWRITERS'
LABORATORIES
FILE #R7776

PRODUCT FEATURES

- **MATERIAL:** 18 GA. (1.2mm) Cold Rolled Steel Frame and Louver Blades, 16 GA. (1.5mm) inner support members.
- **FINISH:** Grey Primer, Beige or Bronze Baked Enamel.
- **INSTALLATION:** Self attaching using #8 x 1" (25mm) phillips head screws that fasten the auxiliary frame to the louver core, thru the cut out in the door. The corridor side of the frame is free of fasteners for added security.
- **DOOR THICKNESS:** 1-3/4" (44mm) Door is Standard. Also available up to FLDL-W: 1-3/4" to 2-1/8" (45mm to 54mm) FLDL-W1: 2-1/8" to 2-9/16" (55mm to 65mm)
- **CLOSING ASSEMBLY:** Stainless steel operating springs assure proper action with the closing mechanism.
- **FREE AIR FLOW:** 40% Free Area.
- **NOTE:** For Exterior use, High Humidity or Salt Air application, product must be Galvanized or Stainless Steel.
- **IMPORTANT:** Interpretation of building and fire codes may vary. Consult with the local authority having jurisdiction in your area, to determine appropriate standards.

OPTIONAL FEATURES

- **MATERIAL:** #304 or #316 Stainless Steel, #4 Finish (Satin), Galvanized (Zinc Plated). Not available in Hot Dipped or Aluminum.
- **FINISH:** Custom Baked Enamel Colors (as per sample chip supplied by customer).
- **FASTENERS:** Special security screw fasteners, See page 14, this section.
- **SPECIALS:** Fractional sizes not available. Height must be in even inches, 1" (25.4mm)
- **SCREENS:** 18-14 mesh insert screens, framed or attached. (Galvanized, Aluminum, Charcoal Aluminum, Stainless Steel). For detail drawings see pages 12 and 13, this section.

FIRE RATING and TEST STANDARDS

UL 10C with Classification Markings

- Approved Listing - 20/45/60/90 Minutes
Max width 24" (610mm), Max height 24" (610mm)
Min width 10" (254mm), Min height 6" (152mm)

BSEN-1634-1:2008 (Fire Resistance)

- Approved Testing - Timber Doors - *30 minutes (E-30)
Max width 24" (610mm), Max height 24" (610mm)
Min width 10" (254mm), Min height 6" (152mm).
*Must be used with Zero Plus Intumescent Aperture Liner

BS 476.22

- Approved Testing - Steel Doors - 120 Minutes (E-120)
Max width 24" (610mm), Max height 24" (610mm)
Min width 10" (254mm), Min height 6" (152mm)

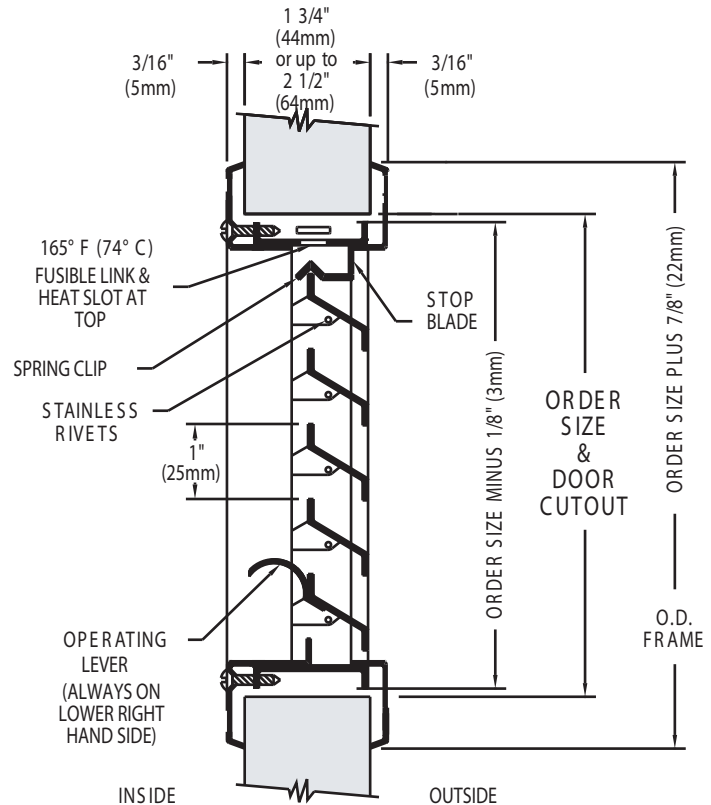
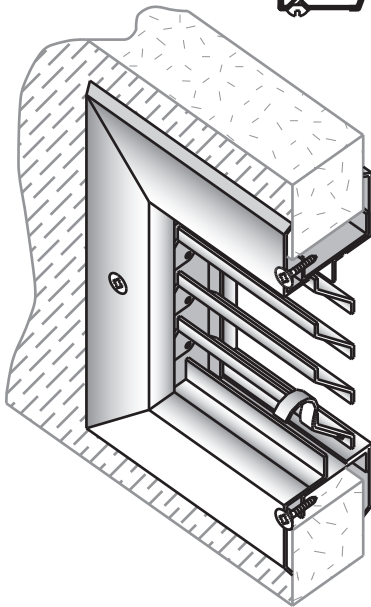
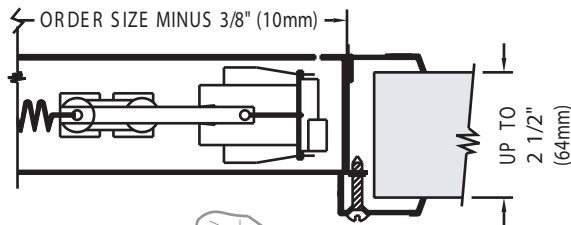

All dimensions are in inches.

JOB NAME:

SUBMITTED BY: