



# Anemostat®

## SUBMITTAL

A MESTEK COMPANY

1220 Watson Center Road • Carson, CA 90745-4206  
 (310) 835-7500 • FAX (310) 835-0448  
 airhelp@anemostat.com • www.anemostat.com

### Model **IJ-D**

## INFINI-JET

### SPLIT VANE DRUM LOUVER

# DIFFUSERS

### PRODUCT FEATURES

- Long throw capability ideally suited for large spaces
- Split vane design improves spread control
- 0° to ±30° Drum Rotation
- #8 sheet metal screws factory provided

### CONSTRUCTION DETAILS

**Material:** Extruded Aluminum

**Finish:**

Arctic White

**Optional Finishes:**

Natural Anodize

Custom Color: \_\_\_\_\_

### MODELS

- IJ-D** Split Vane Drum Louver
- IJ-D-P** Split Vane Drum Louver with Pole Operator

### OPTIONS

- Frame Gasketing
- Model OB-1** Steel Opposed Blade Damper
- Model OB-1** Aluminum Opposed Blade Damper

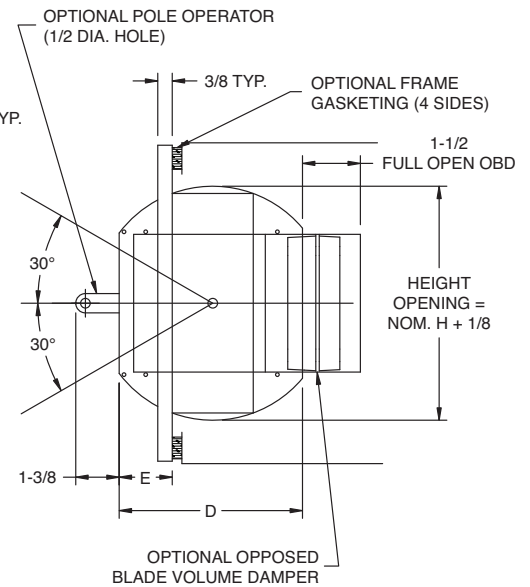
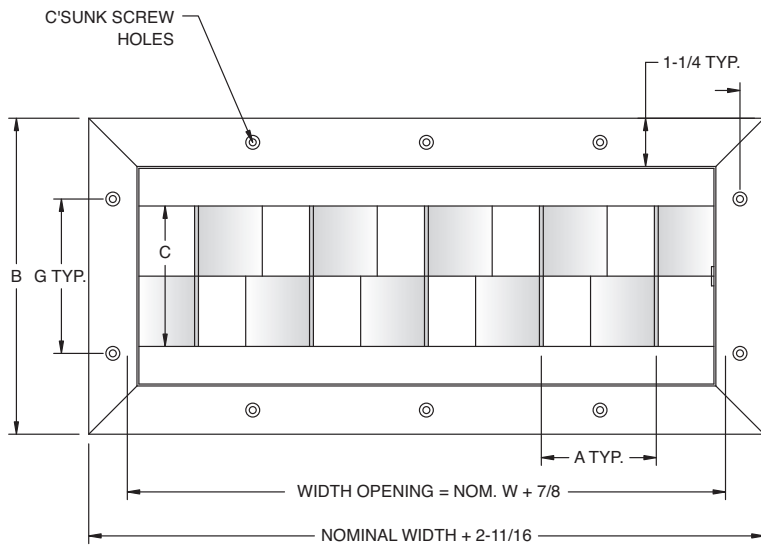

6"	10"	12"	15"
W x H	W x H	W x H	W x H
9x6	20x10	20x12	15x15
12x6	25x10	25x12	20x15
18x6	30x10	30x12	25x15
24x6	35x10	35x12	30x15
30x6	40x10	40x12	40x15
36x6	50x10	50x12	50x15
48x6	60x10	60x12	60x15
60x6	70x10	70x12	70x15

NOM. HEIGHT (DRUM DIA.)	A	B	C	D	E	G
6" UNITS	3	8-3/16	3-7/16	4-3/4	1-3/8	-
10" UNITS	5	11-15/16	5-15/16	7-5/8	2-1/4	6
12" UNITS	5	13-15/16	6-13/16	7-5/8	3	6
15" UNITS	5	17	9-3/4	7-13/16	3-5/8	9

All dimensions are in inches.

JOB NAME:

SUBMITTED BY: