

SUBMITTAL SHEET

PRODUCT FEATURES

- 1/2" x 1/2" x 1" aluminum core
- Registers include a factory attached, steel opposed blade volume control damper
- Surface mounting holes in frame neatly countersunk for supplied #8 x 1-1/4" oval head screws

CONSTRUCTION DETAILS

Material:

- Aluminum Frame
- Steel Frame

Finish:

- Arctic White (std)
- Custom Color (opt)

Accessories

- OB** Opposed Blade Damper

SURFACE MOUNTED

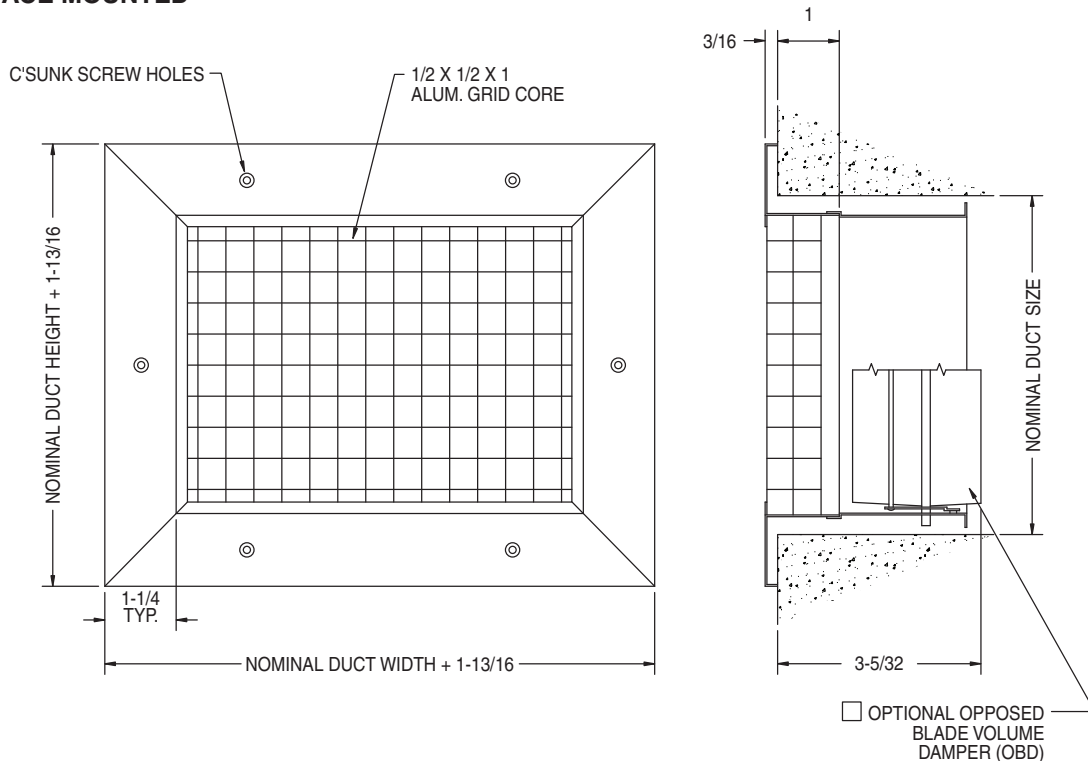

LAY-IN T-BAR

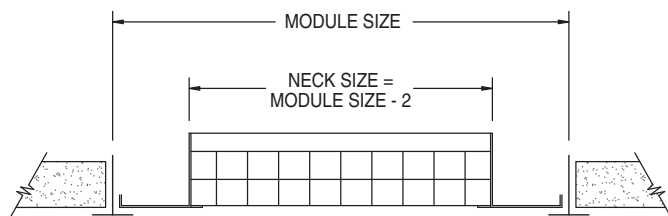

MODULE SIZE	NECK SIZE
12 x 12	10 x 10
12 x 24	10 x 22
24 x 24	22 x 22
24 x 48	22 x 46

For T-Bar Applications,
Order Neck Size Shown
- NO SCREW HOLES

All dimensions are in inches.

JOB NAME:

SUBMITTED BY: