



Anemostat®

SUBMITTAL

A MESTEK COMPANY

1220 Watson Center Road • Carson, CA 90745-4206
 (310) 835-7500 • FAX (310) 835-0448
 air@anemostat.com • www.anemostat.com



Model **FGC5**
HINGED RETURN FILTER GRILLE
 ALUMINUM GRID CORE
 1/2" x 1/2" x 1/2"
 TEGULAR

GRILLES & REGISTERS

PRODUCT FEATURES

- Aluminum Grid Core, 1/2" x 1/2" x 1/2"
- Piano Hinge Construction
- 1/4-Turn Latch(es). Qty=2 on size 24" & up
- Concealed fastening thru neck of grille
- Recommended Filter Size (Actual) = (Nom Width - 1/2") x (Nom Height - 1/2")

CONSTRUCTION DETAILS

Material:

- Steel
- Aluminum

Finish:

- Arctic White
- Satin Polish
- Custom Color _____

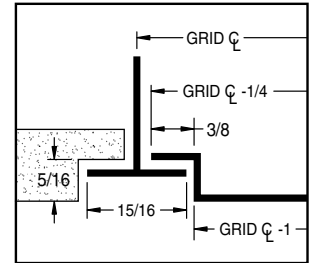

15/16" TEGULAR

AVAILABLE SIZES

MODULE SIZE	MAX NECK SIZE
12 x 12	10 x 10
12 x 24	10 x 22
24 x 24	22 x 22
24 x 48	22 x 46

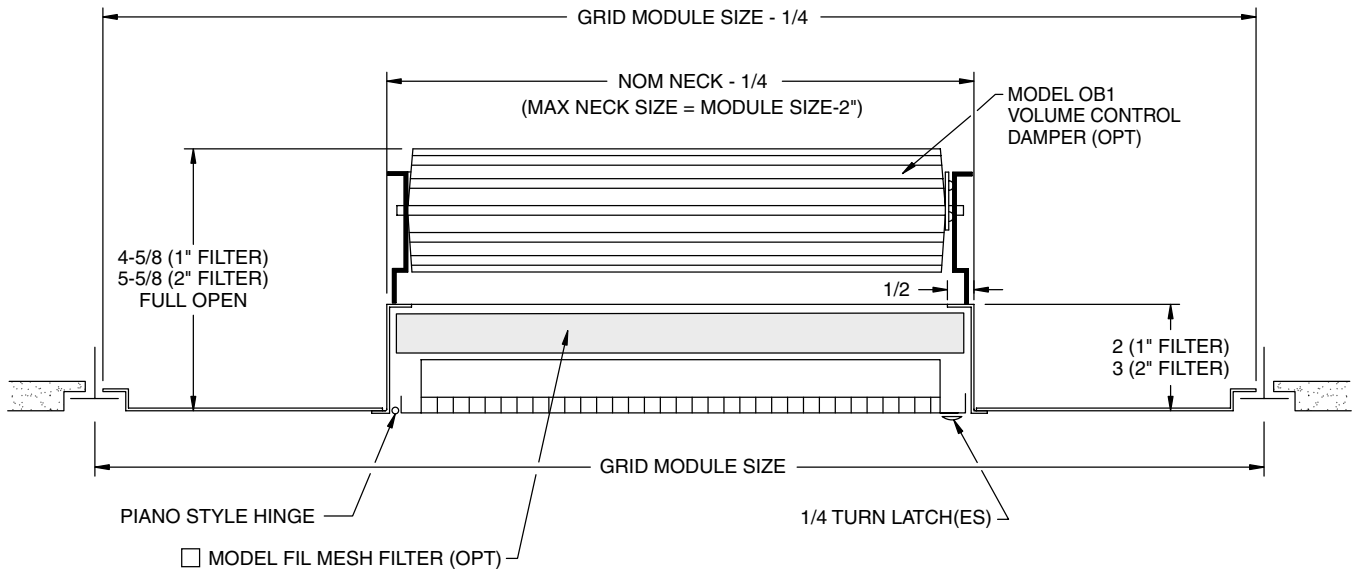

MODEL	FILTER SIZE	TYPE	DUCT (W X H)	APPLICATION	MODULE
FGC5	1L	H	12.00 / 12.00	T	22
Aluminum Grid Core	1 1" Filter 2 2" Filter 1S 1" Filter, Hinge on Short Dim. 1L 1" Filter, Hinge on Long Dim. 2S 2" Filter, Hinge on Short Dim. 2L 2" Filter, Hinge on Long Dim.	Hinged Core		Tegular	- N/A 11 12" x 12" 12 12" x 24" 22 24" x 24" 24 24" x 48"

Dimensions are in inches (millimeters).

JOB NAME:

SUBMITTED BY: