



Anemostat®

SUBMITTAL

A MESTEK COMPANY

1220 Watson Center Road • Carson, CA 90745-4206
 (310) 835-7500 • FAX (310) 835-0448
 air@anemostat.com • www.anemostat.com



Model **FGC5**
HINGED RETURN FILTER GRILLE
 ALUMINUM GRID CORE
 1/2" x 1/2" x 1/2"
 SURFACE MOUNTED

GRILLES & REGISTERS

PRODUCT FEATURES

- Aluminum Grid Core, 1/2" x 1/2" x 1/2"
- Piano Hinge Construction
- 1/4-Turn Latch(es). Qty=2 on size 24" & up
- Concealed fastening thru neck of grille
- Sizes 6" x 4" to 48" x 48" maximum single piece construction
- Recommended Filter Size (Actual) = (Nom Width - 1/2") x (Nom Height - 1/2")

CONSTRUCTION DETAILS

Material:

- Aluminum

Finish:

- Arctic White
- Satin Polish
- Custom Color _____

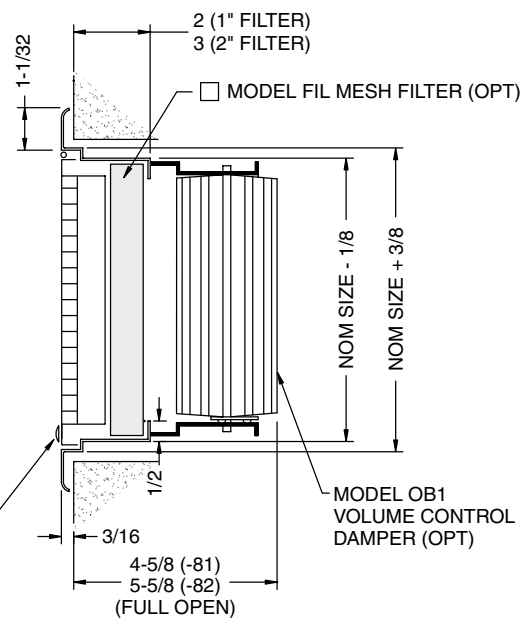
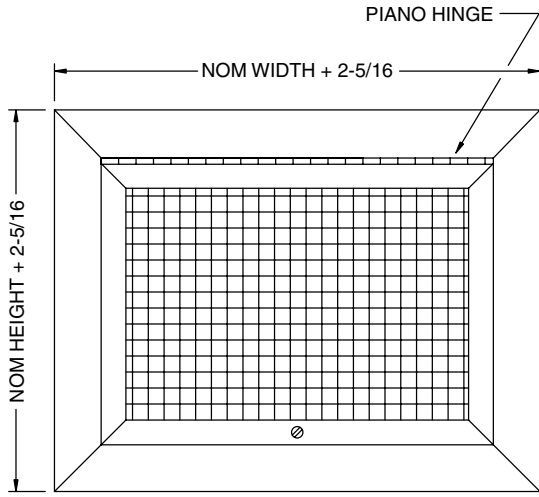

1/4 TURN LATCH

MODEL FGC5

Aluminum
Grid Core

FILTER SIZE 1L

- 1 1" Filter
- 2 2" Filter
- 1S 1" Filter, Hinge on Short Dim.
- 1L 1" Filter, Hinge on Long Dim.
- 2S 2" Filter, Hinge on Short Dim.
- 2L 2" Filter, Hinge on Long Dim.

TYPE H

Hinged
Core

DUCT (W X H) 24.00 / 12.00

06.00 to 48.00
6" up to 48"

Dimensions are in inches (millimeters).

JOB NAME:

SUBMITTED BY: