

Anemostat®

SUBMITTAL

A MESTEK COMPANY

1220 Watson Center Road • Carson, CA 90745-4206
 (310) 835-7500 • FAX (310) 835-0448
 air@anemostat.com • www.anemostat.com



Model F30
HINGED RETURN FILTER GRILLE
 45° DEFLECTION
 3/4" BLADE SPACING
 CONCEALED SPLINE

GRILLES & REGISTERS

PRODUCT FEATURES

- 3/4" Louver Spacing
- Piano Hinge Construction
- 1/4-Turn Latch(es). Qty=2 on size 24" & up
- Core deflection opposite hinge side as shown (default, as applicable)
- Louvers parallel to short or long dimension
- Recommended Filter Size (Actual) = (Nom Width -1/2") x (Nom Height -1/2")

CONSTRUCTION DETAILS

Material:

- Stainless Steel

Finish:

- Arctic White
- Satin Polish
- Custom Color _____

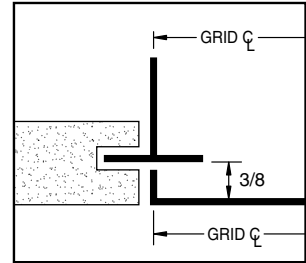

CONCEALED SPLINE

AVAILABLE SIZES

MODULE SIZE	MAX NECK SIZE
12 x 12	10 x 10
12 x 24	10 x 22
24 x 24	22 x 22
24 x 48	22 x 46

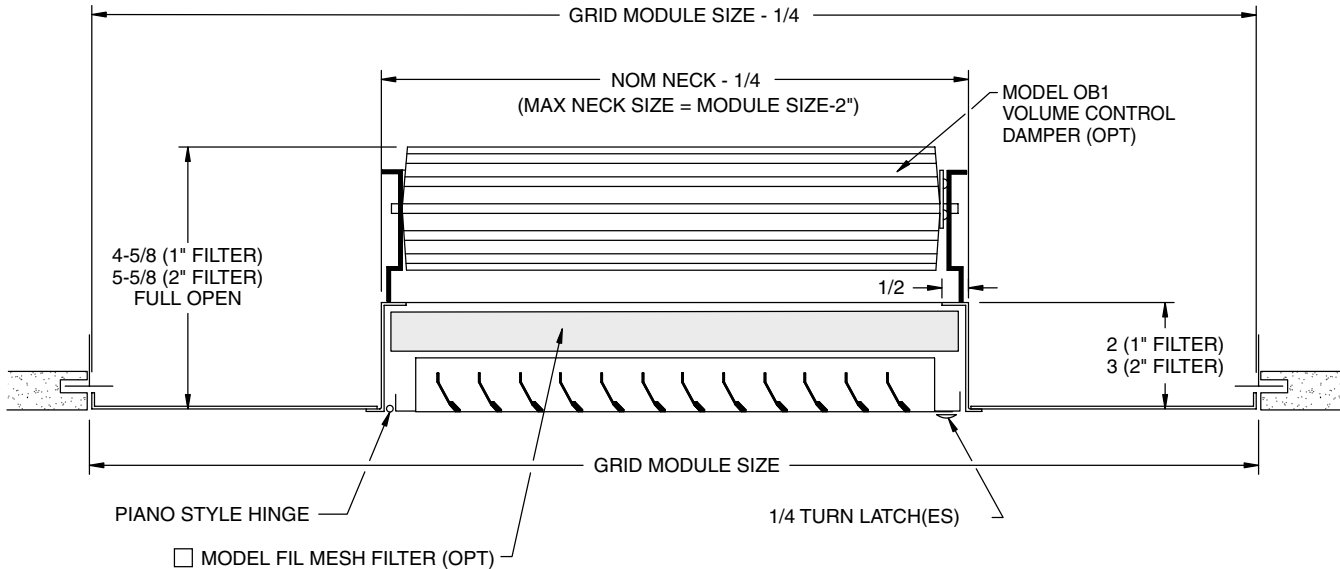

MODEL	FILTER SIZE	TYPE	BLADE DIR.	DEFL.	DUCT (W X H)	APPLICATION	MODULE
F30	1L	H	L	45	12.00 / 12.00	C	22
3/4" Blade Spacing	1 1" Filter 2 2" Filter 1S 1" Filter, Hinge on Short Dim. 1L 1" Filter, Hinge on Long Dim. 2S 2" Filter, Hinge on Short Dim. 2L 2" Filter, Hinge on Long Dim.	Hinged Core	- N/A (Sq.) L Long Blade S Short Blade	45°		Concealed Spline	- N/A 11 12" x 12" 12 12" x 24" 22 24" x 24" 24 24" x 48"

Dimensions are in inches (millimeters).

JOB NAME:

SUBMITTED BY: