



Anemostat®

SUBMITTAL

A MESTEK COMPANY

1220 Watson Center Road • Carson, CA 90745-4206
 (310) 835-7500 • FAX (310) 835-0448
 air@anemostat.com • www.anemostat.com



Model F30
HINGED RETURN FILTER GRILLE
 0° DEFLECTION
 3/4" BLADE SPACING
 SURFACE MOUNTED

GRILLES & REGISTERS

PRODUCT FEATURES

- 3/4" Louver Spacing
- Piano Hinge Construction
- 1/4-Turn Latch(es). Qty=2 on size 24" & up
- Concealed fastening thru neck of grille
- Louvers parallel to short or long dimension
- Sizes 6" x 4" to 48" x 48" maximum single piece construction
- Recommended Filter Size (Actual) = (Nom Width - 1/2") x (Nom Height - 1/2")

CONSTRUCTION DETAILS

Material:

Steel

Finish:

- Arctic White
 Satin Polish
 Custom Color _____

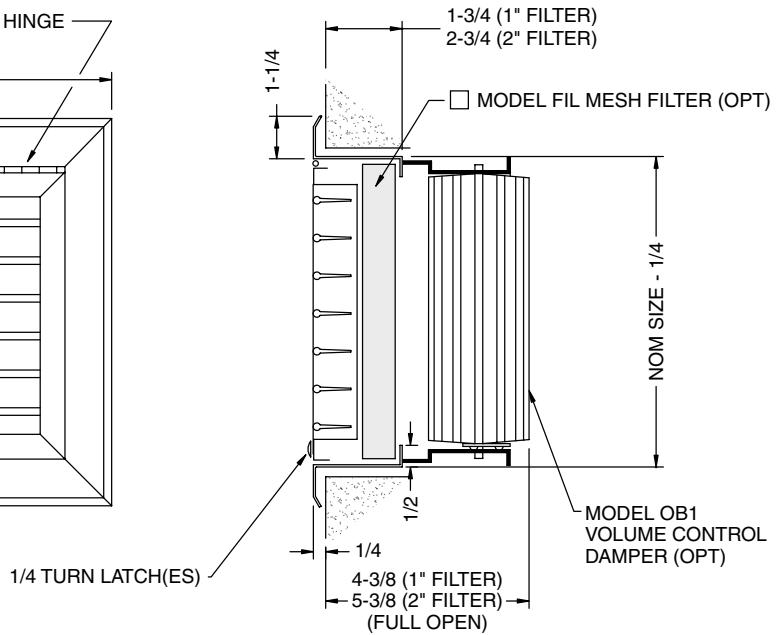
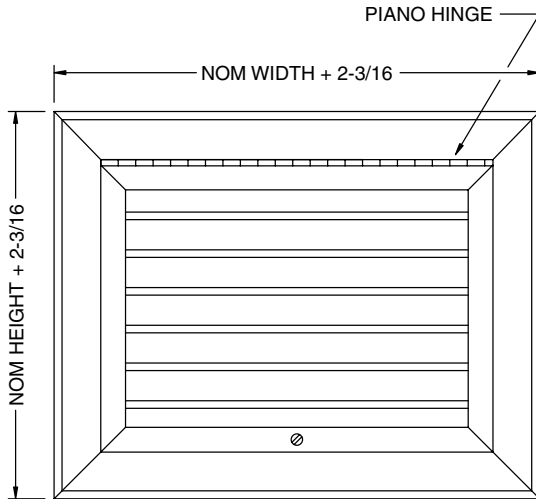

MODEL	FILTER SIZE	TYPE	BLADE DIR.	DEFL.	DUCT (W X H)
F30	1L	H	L	0	24.00 / 12.00
3/4" Blade Spacing	1 1" Filter 2 2" Filter 1S 1" Filter, Hinge on Short Dim. 1L 1" Filter, Hinge on Long Dim. 2S 2" Filter, Hinge on Short Dim. 2L 2" Filter, Hinge on Long Dim.	Hinged Core	- N/A (Sq.) L Long Blade S Short Blade	0°	06.00 to 48.00 6" up to 48"

Dimensions are in inches (millimeters).

JOB NAME:

SUBMITTED BY: