



Anemostat[®]
AIR DISTRIBUTION

SUBMITTAL SHEET

www.anemostat-hvac.com

Model **C1/KIT**
HANGER BRACKETS
FOR AIR TERMINALS

PRODUCT FEATURES

- (4) brackets per kit used to support air terminal from structure above.
- Can be used with threaded rod or hanger wire.
- Shipped loose, field installed*

CONSTRUCTION FEATURES

Material:
16 gauge galvanized steel

MODELS

- C1/KIT**(4) Hanger Brackets

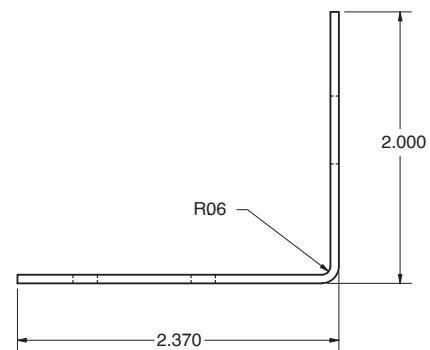
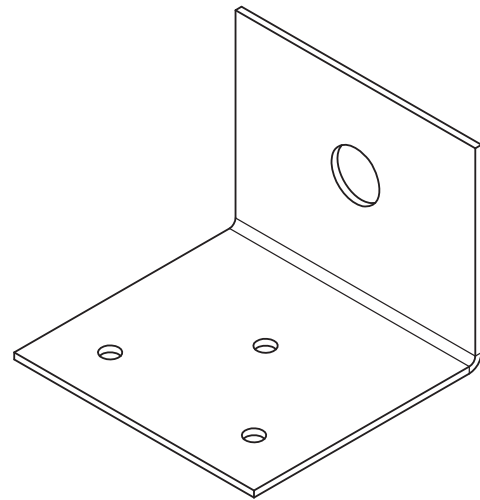
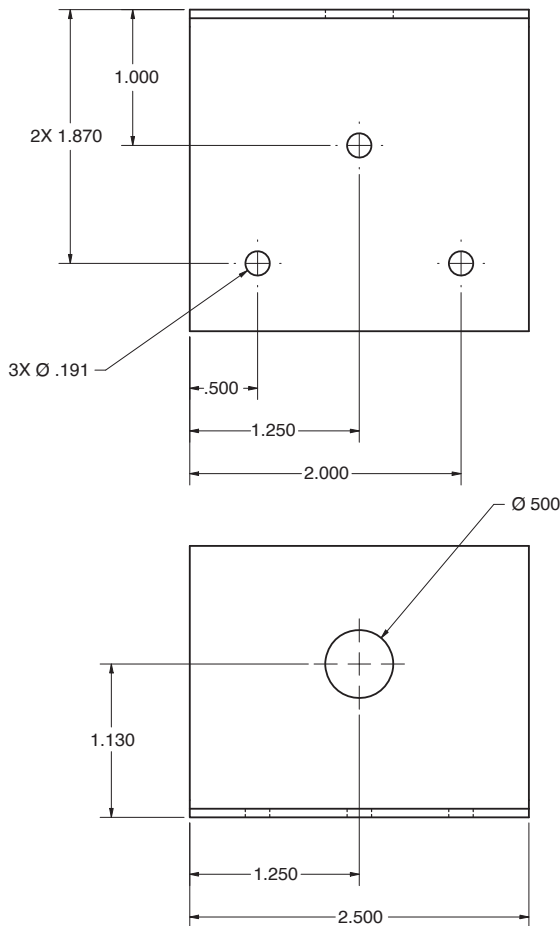

* Proper product installation is the responsibility of the installer as dictated by industry standards, codes, and/or specifications.

All dimensions are in inches.

JOB NAME:

SUBMITTED BY: