

PRODUCT FEATURES

- Inlet sizes available: 5", 6", 8", 9", 10", 12", 14", & 16".
Hot & cold inlet diameters can be different sizes.
 - Inlet sensing only.
 - 1 or 2 row hot water heating coil
Right hand or Left Hand connections
 - 22 gauge zinc-coated steel, low leakage casing construction sealed during assembly
Optional:
 - 20 gauge construction
 - Ultra Lo-Leak construction
 - 1/2" dual density insulation (NFPA 90A & UL181).
Optional:
 - 1" dual density insulation
 - 1/2"
 - 1" foil faced glass fiber insulation metal taped edges (ASTM C665)
 - 1" Fiber-Lok insulating system foil faced insulation with steel encapsulated edges (ASTM C665)
 - 3/8" fiber free closed cell foam insulation (NFPA 255, UL181)
 - No Insulation
 - Slip and Drive cleat hot water coil discharge duct connection.
 - Integral discharge sound attenuator and radiated noise shroud.
 - Multi-Point center averaging Velocity Wing airflow sensor in each inlet for accuracy to +/- 5% of design flow.
 - Balancing taps / Calibration chart included for field adjustment (where applicable).
 - Hot inlet may be Right or Left Handed, Hot and Cold valves.
 - Sequences available for Pneumatic, Electronic Analog, or Direct Digital Control systems.
- Optional Accessories:
- Hinged 6 x 6 bottom access door
 - Double Camlock 6 x 6 access door
 - Unit mounting brackets
 - Control Enclosures

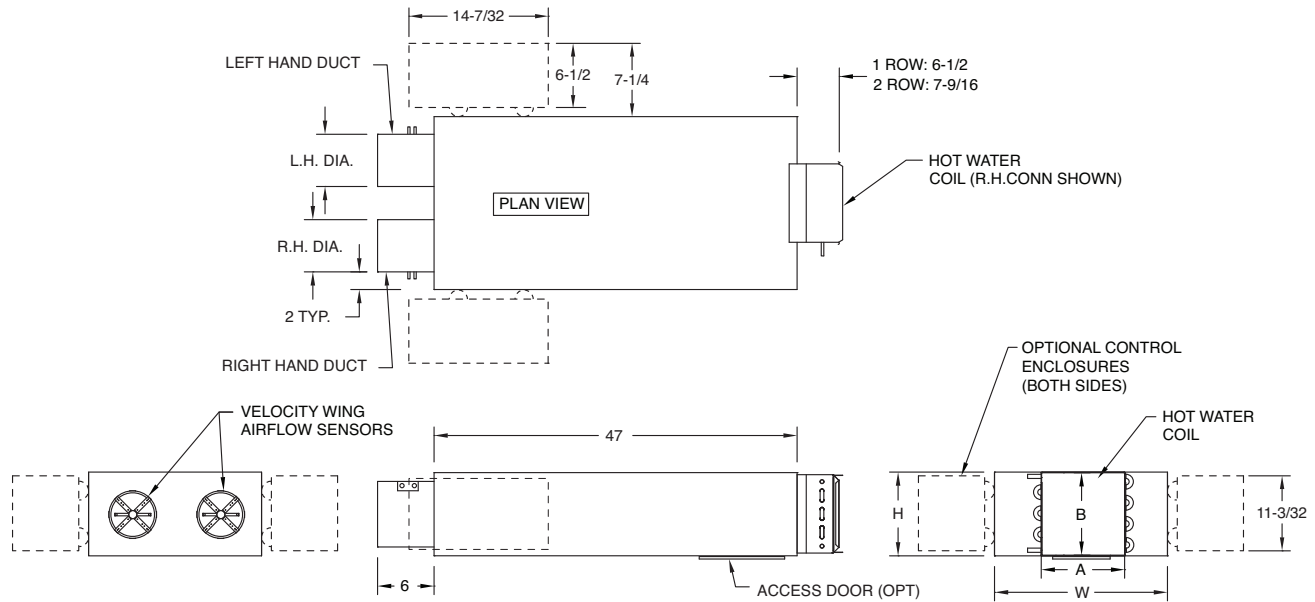

MODEL DU1R							
BOX SIZE	MAX. INLET DIA.	BOX		DISCHARGE DUCT		COIL CONN (OD)	
		W	H	A	B	1 ROW	2 ROW
A	6	22	10	10	10	1/2	1/2
B	8	22	10	12	10	1/2	1/2
C	10	26	12	14	12-1/2	1/2	1/2
D	12	30	14	16	15	7/8	1/2
E	14	34	16	20	17-1/2	7/8	7/8
F	16	38	18	24	17-1/2	7/8	7/8

INLET CAPACITY	
INLET DIA.	CFM*
5	50 - 290
6	80 - 470
7	105 - 610
8	150 - 870
9	190 - 1100
10	235 - 1355
12	310 - 1800
14	430 - 2470
16	585 - 3370

* OR 0 FLOW All dimensions are in inches.

JOB NAME: _____ **SUBMITTED BY:** _____