

Applications Guide



General Information	2
CSP-5001/5002 Overview.....	2
Controller, Sensor, and Thermostat Functions	3
Wiring.....	4
Air Flow Sensor Connection.....	4
Rotation Setup.....	4
Controller Testing	5
System Troubleshooting.....	5
Controller Calibration	6
Minimum and Maximum Flow Limits.....	6
VNOM (CFM) Range Setting.....	6
CTE-5100 Series Thermostat Reference	7
Checkout and Calibration	7
CTE-5100 Series Cross-Reference.....	8
Changing a CTE-5100 Thermostat to a Remote Sensor.....	9
Applications	11
Cooling or Heating.....	11
Auto, Override to Fully Closed, or Override to Fully Open.....	12
Cooling with 3-Stage Reheat	13
Cooling with 3-Stage Reheat and 10 Degree Night Setback/Setup.....	14
Cooling with Heating Changeover.....	15
Cooling with Heating Changeover and Electric Reheat	16
Cooling with Heating Changeover and Hot Water Reheat.....	17
Cooling with Hot Water Reheat	18
Dual Duct, Minimum Air From Cold Duct	19
Fan Induction with 2-Stage Electric Heat	20
Index	21

General Information

CSP-5001/5002 Overview

The analog electronic CSP-5001/5002 VAV flow controller-actuators are pressure-independent combination controller-actuators designed primarily for use on variable air volume terminal units. Air flow is sensed by using a single or multi-point differential (velocity) pressure measuring station or pitot tube. Designed with an onboard flow-through sensor utilizing twin platinum resistance temperature detectors, these models are capable of controlling a velocity setpoint from 0 to 3,300 fpm with an accuracy of 3%.

The CSP-5001/5002 offers full range flow control of VAV terminal units when used with the CTE-5100 series room thermostats. Air velocity flow control limits may be set at the thermostat or internal to the CSP-5001/5002. The actuator section provides adjustable stops, magnetic clutch and a gear disengagement button.

On older models, a tri-color LED indicates green for opening, red for closing and white/off for satisfied damper positions. On newer models, two separate red and green LEDs indicate opening and closing.

Two models are available:

CSP-5001: CCW to close

CSP-5002: CW to close

Available control options include proportional or two position wet or electric reheat, dual minimums, fan induction, dual duct, and 0–5 VDC output to a building automation system interface.

For more information, see the [Data Sheet](#) and the [Installation Guide](#) for the CSP-5001/5002.

NOTE: For use with the CTE-5202 thermostat instead of the CTE-5100 series, see the [CTE-5202 Applications Guide](#).

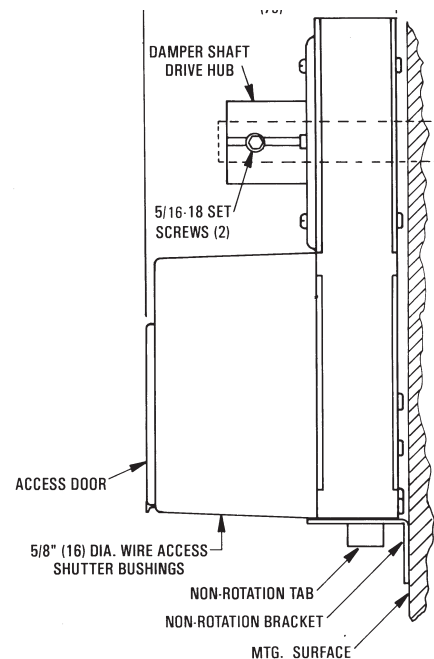
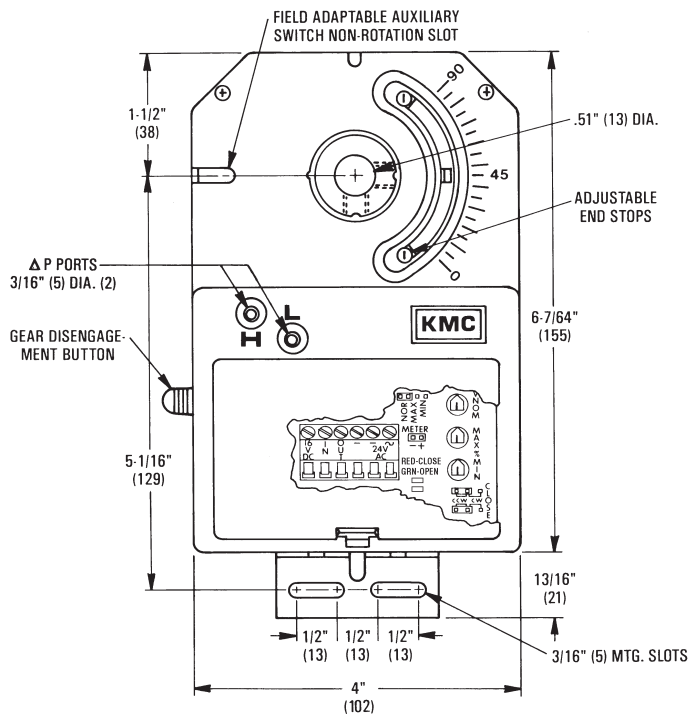

Controller, Sensor, and Thermostat Functions

The Controller: The controller is designed to:

1. Receive a “desired flow” signal from the thermostat (0–10 volts on terminal “IN”), or the minimum and maximum settings on the controller itself.
2. Compare it to “actual flow” (on terminals “out” and “-”).
3. And drive the box open/closed, as required to match airflow.

LEDs show which direction the actuator is rotating (green when opening, red when closing). The CSP-5001 is factory-set to close counter-clockwise; the CSP-5002, clockwise. However, rotation direction is field-changeable via jumper selection (see the Rotation Setup section).

The CSP-5001 is factory set to measure airflow of 0–3300 fpm at a 0–10 volt signal. This airflow is field adjustable to match a specific requirement within these ranges (see the Controller Calibration section).

The Flow Sensor: The CSP-5001/5002 controllers use an onboard flow-through sensor utilizing twin platinum resistance temperature detectors to electronically measure air velocity in the duct.

The chart below illustrates typical voltage versus velocity using a CSP with a SSS-1002, single-point flow sensor. Because this is a flow-through type sensor, the tubing type will directly affect flow readings. **To maintain a close correlation with the factory calibration, installations must use 24 inches of 1/4-inch OD x 0.040 wall tubing without restrictions such as fittings or kinks.** The voltage corresponds to both “IN” (for desired flow) and “OUT” (for actual flow) terminals.

The Thermostat: The CTE-5100 series thermostats are designed for use with the CSP-5001/5002 Controllers and/or most other controls (using a half-wave rectifier power supply) requiring a 0–10 volt signal. Some of these controls are: the REE-1000/5000 series relays, the MEP-1200/5000 series actuators, and/or the VEP series valves. Utilizing the MEP actuators, the CTE-5100 allows setting minimum and maximum control points on the thermostat (see Thermostat Checkout/Calibration Procedures).

Various thermostat models are available in this series such as: single setpoint DA (5101), single setpoint RA (5102), dual setpoint DA and RA (5103/5104), and dual setpoint both DA (5105).

Typical Voltage/Velocity Chart

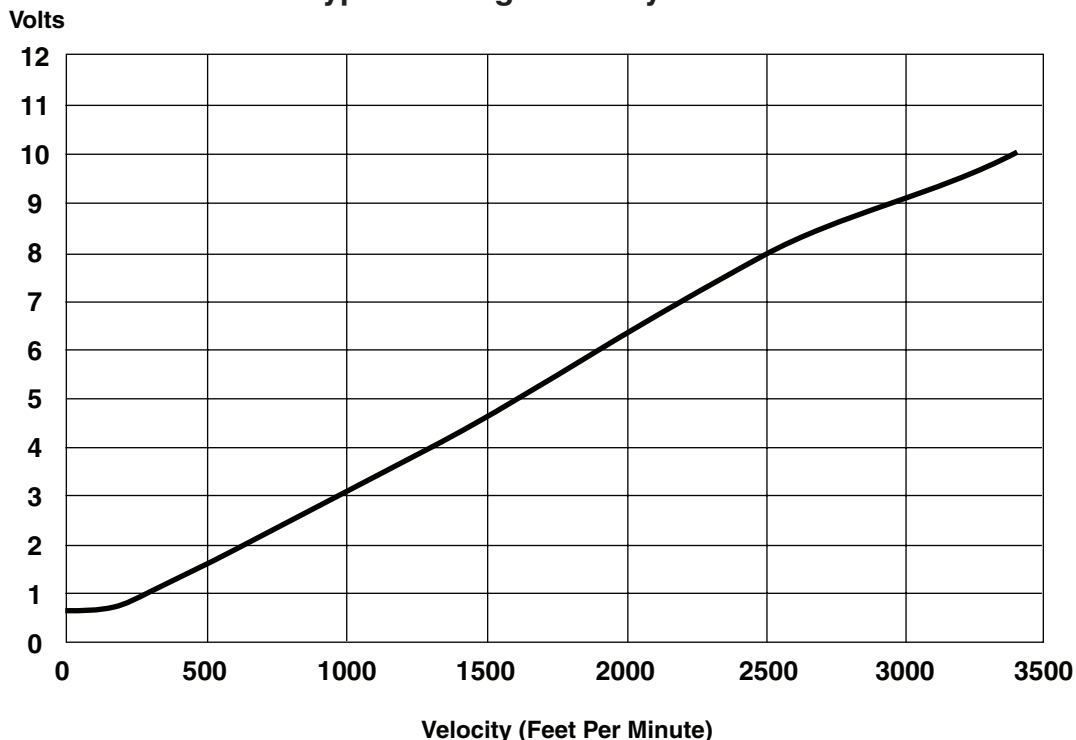

(CSP-5001 with the SSS-1002 in a 5-inch duct and 24 inches of 1/4-inch OD x 0.040 wall tubing)

Wiring

1. Remove the CSP's wiring access door by pulling back on the door's tab and lifting upward.
2. Access for wire or cable is via two 5/8 in. (16 mm) diameter snap-in shutter bushings located on the rear of the CSP's cover.
3. Connect conduit to the actuator if required (connectors are not supplied—order separately):
 - A. HMO-4518 for 1/2 in. flexible conduit.
 - B. HMO-4520 compression connector for plenum rated cable.
 - C. HMO-4526 for rigid 1/2 in. conduit.
4. Remove snap-in shutter bushing and replace with the HMO-4518 or HMO-4520 if required.
5. Connect the CSP to a CTE-5100 thermostat:
 - A. Terminal "16 VDC" to thermostat terminal "+".
 - B. Terminal "IN" to thermostat terminal "T1" for cooling or "T2" for heating air flow.

NOTE: If minimum and maximum velocity limits will be set at the CSP, then use "T3" for cooling and "T4" for heating.

- C. Terminal "OUT" to thermostat terminal "V1" for velocity readout at thermostat.
 - D. Terminal "-" to thermostat terminal "-".
6. Connect the CSP to a 24 volt AC, -15/+20%, 50/60 Hz power source:
 - A. Terminal "~" to the phase side of the 24 volt AC transformer.
 - B. Terminal "-" to the neutral or ground side of the transformer.
 7. Replace wiring access door.

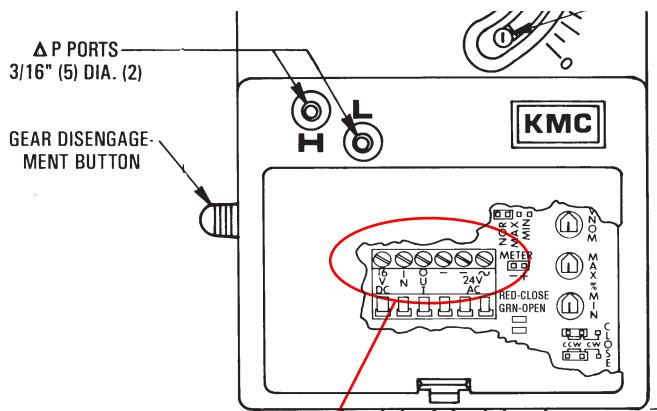

WIRING

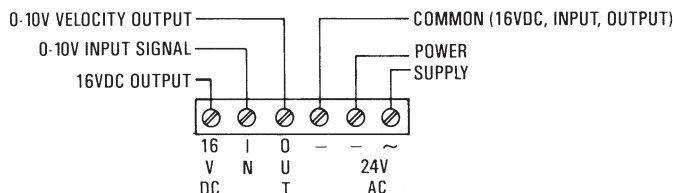

Air Flow Sensor Connection

Using 24 inches of 1/4-inch OD x 0.040-inch wall FR instrument and control tubing, connect the CSP to an SSS-1000 series differential pressure flow sensor:

1. Connect the "H" port to the (high side) "H" of the sensor.
2. Connect the "L" port to the (low side) "L" of the sensor.

NOTE: To maintain a close correlation with the factory calibration (for 0 to 3300 fpm), installations, on both High and Low sides, must use **exactly** 24 inches of the tubing without restrictions such as fittings or kinks.

NOTE: The SSS-1000 series differential pressure flow sensor must be mounted with the arrow pointing in the direction of the air flow.

Rotation Setup

The CSP-5001 is factory-set for CCW to close. The CSP-5002 is factory-set for CW to close. To reverse the rotation direction of either controller model:

1. Remove the access door by pulling back on the door's tab and lifting upward.
2. Position both jumpers in either the CW or CCW positions as needed. See the diagram.

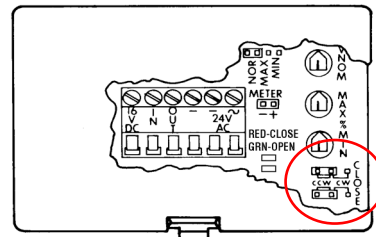

Controller Calibration

Minimum and Maximum Flow Limits

Minimum and maximum flow limits are often set at the CTE-5100 series thermostat (see the CTE-5100 Series Thermostat Reference section). If desired, the minimum and maximum limits can be defined by adjusting the appropriate setpoints within the CSP-5001/5002 controller (see below) instead, but **do not try to set the limits at BOTH the controller and the thermostat (or else the limits will not reflect either the controller's or the thermostat's limits).**

To set the velocity limits at the CSP:

1. Remove the access door by pulling back on the door's tab and lifting upward.
2. Connect a voltmeter to the meter taps (using HSO-5001 test leads).
3. Move the jumper from the NOR (normal) position (two left-most pins) to the MIN position (two right-most pins).
4. Adjust the MIN potentiometer for the desired minimum voltage.

NOTE: MIN must be adjusted first.

5. Move the jumper to the MAX position (two center pins).
6. Adjust the MAX potentiometer to the desired maximum voltage.
7. Return the jumper to the NOR position.

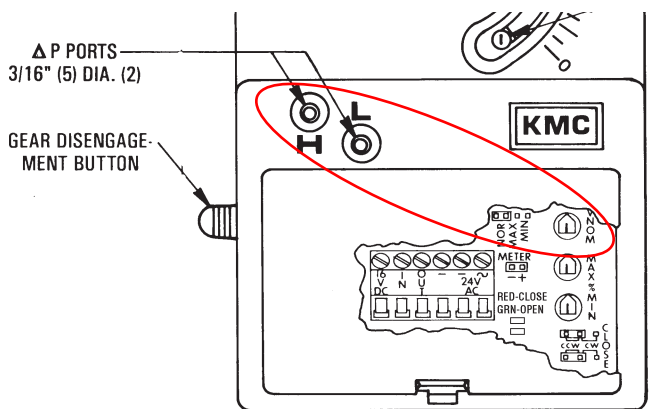
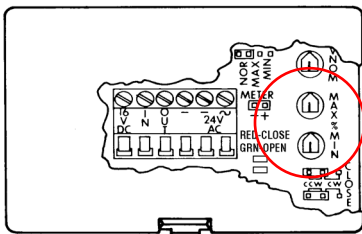

VNOM (CFM) Range Setting

The CSP range is factory-calibrated with the VNOM potentiometer centered. Using any SSS-1002/1003/1004/1005 series velocity pickup, tubing, and reducers, the CSP will have a range of 0–3,300 fpm with a 0–10 volt DC reset control signal.

Leaving the VNOM at the factory setting is recommended! Changing the VNOM potentiometer from the factory setting will alter the calibration between the "IN" and "OUT" voltages. However, the VNOM can be adjusted to match 0–10 volts to a specific velocity range if desired.

NOTE: In the controller, VNOM stands for "NOMinal Volumetric flow rate."

To set the VNOM range to a different range than the factory default (a new curve):

1. Remove the access door by pulling back on the door's tab and lifting upward.
2. Supply the desired high end of range velocity to the "H" and "L" ports.
3. Connect a voltmeter between the "OUT" and "-" terminals and adjust the VNOM potentiometer until the voltage equals 10 volts DC.

To return the VNOM range to the factory default range of 0–3300 fpm as illustrated in the chart on page 3:

1. Remove the access door by pulling back on the door's tab and lifting upward.
2. Supply or simulate a 3300 ft/min velocity (or 0.5" delta P) at the "H" and "L" ports.
3. Connect a voltmeter between the "OUT" and "-" terminals and adjust the VNOM potentiometer until the voltage equals 10 volts DC.

OR

2. Measure the velocity of the airflow measured by the "H" and "L" ports.
3. Connect a voltmeter between the "OUT" and "-" terminals and adjust the VNOM potentiometer until the voltage at the meter equals the corresponding voltage from the chart on page 3. The higher the flow, the more accurate the adjustment.

CTE-5100 Series Thermostat Reference

Checkout and Calibration

The thermostat (CTE-5100 series) operates on a 16 volt DC power supply from the CSP controller and outputs a 0–10 volt DC signal on the T(x) terminals (Direct Acting T1 and Reverse Acting T2). See the CTE-5100 Series Thermostat Reference Page for details on which ‘T’ terminals are used on each model thermostat, but generally T1 and T3 are used for the cooling mode and T2 and T4 for heating. T1 and T2 are adjustable to limit minimum and maximum flow. T3 and T4 have a fixed 0–10 volt DC output signal (over the proportional band).

NOTE: Limits may be set at the CSP or the CTE thermostat. If setting the min/max limits at the CTE thermostat, the CSP’s Min. dial must be set fully CCW to 0 and the Max. dial set fully CW to 100. This will ensure that the CSP will not have any effect on the limits.

1. Required tools:

- 1/16-inch hex/key wrench
- Small flat blade (1/8-inch) screwdriver
- Digital voltmeter capable of displaying a 0–10 volt DC range which will display in hundredths of a volt.
- HSO-5001 test leads (optional for meter taps)

2. Remove the thermostat cover by loosening the setscrews on each side of the thermostat (see illustration). Using a 1/16-inch hex key wrench, turn the setscrews **clockwise** until the cover is loose.

3. Check voltages:

- A. Verify 16 volts DC between (+) and (–) terminals.
- B. Measure “T(x)” to “–” for output voltage. Use the calibration procedures below to adjust limits if desired. Adjust the setpoint above and below current room temperature and observe changes in appropriate “T” voltage. Remove setpoint slider stops (HFO-0027) if necessary.

NOTE: Always adjust minimum flow limits first.

4. Maximum limits will always be greater than minimum limits. (Maximum is additive to minimum.) If in doubt, turn maximum limit fully clockwise (increase) before proceeding.

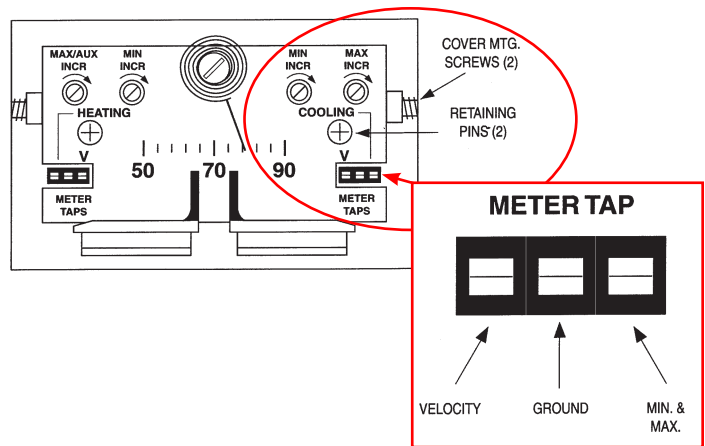

NOTE: Dials rotate approximately 200° (8:00 to 4:00). Turn clockwise to increase or counterclockwise to decrease. Do not use excessive force on dials. They should turn freely and effortlessly. **DO NOT force dial beyond a stop.**

5. Connect voltmeter to the meter taps (using the HSO-5001 test leads adapter makes this easier).
 - A. Connect to the middle and right terminal (see illustration) for the minimum and maximum reading.
 - B. Connect to the middle and left terminal for measuring actual flow velocity. (The thermostat must be wired to a controller for this option; see the Applications sections).
6. Adjust the minimum flow.
 - A. Push the cooling setpoint slider all the way to the **right**. (This requests minimum flow, and is normally for heating mode or cooling is satisfied.)
 - B. Set the minimum flow voltage as desired using the Min. dial (on the Cooling side of thermostat).
7. Adjust the maximum flow.
 - A. Push the cooling setpoint slider all the way to the **left**. (This requests maximum flow, and is normally for full cooling mode.)
 - B. Set the maximum flow voltage as desired using the Max. dial (on the Cooling side of the thermostat).
8. Adjust the cooling setpoint slider back to its original position and replace the cover.

NOTE: For use with the CTE-5202 thermostat instead of the CTE-5100 series, see the [CTE-5202 Applications Guide](#).

CTE-5100 Series Cross-Reference

CTE-5100 Series Thermostat Cross-Reference					
Thermostat Terminals	5101	5102	5103/ 5105	5104	Terminal Description
V1	X		X	X	Velocity input; connect to "out" terminal on CSP for readout.
T3	X		X	X	Upper set point output w/o limits (0–10 volt fixed signal; can be measured on back of stat).
R1	X		X	X	T1 override, connect to "–" if unused. Voltage applied subtracts from T1.
T1	X		X	X	Upper set point output, with limits; adjustable at pot. on front of the thermostat.
+	X	X	X	X	16 volts DC power supply input.
12V	X	X	X	X	12 volts DC output for temperature averaging.
A	X	X	X	X	Temperature averaging input.
–	X	X	X	X	Ground reference.
T2		X	X	X	Lower setpoint output with limits; adjustable at potentiometer on front of the thermostat.
R2*		X	X	X	T2 override, connect to "–" if unused.* Voltage applied subtracts from T2.
T4		X	X		Lower set point output w/o limits.
V2		X	X		Velocity input for readout; connect to "out" terminal on CSP for readout.

* R2 is auxiliary limit trigger on CTE-5104. Voltage above 1 volt triggers T1 to the Aux. Flow Limit. The application would be a single duct cooling with reheat where the minimum flow is not enough to satisfy the reheat demand.

NOTE: If desired, the thermostat scale plate can be reversed so that a blank metal plate appears in the thermostat window instead of the temperature coil indicator and scale. To do so, remove the cover, pull out the two retaining pins, reverse the plate, reinsert the pins, and reinstall the cover. This does not affect the thermostat operation.

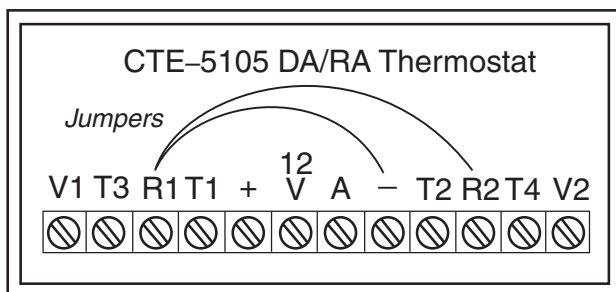
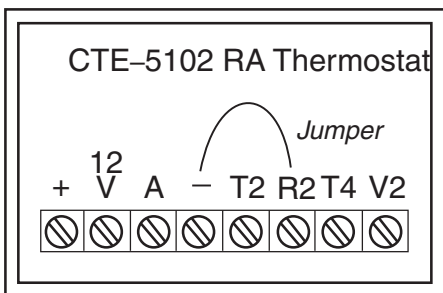
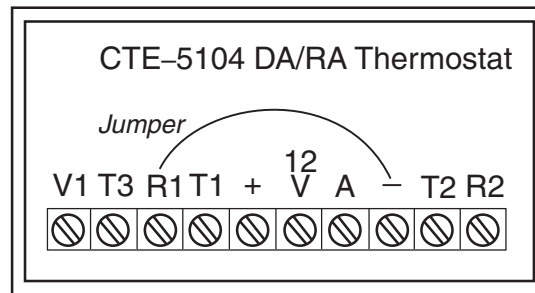
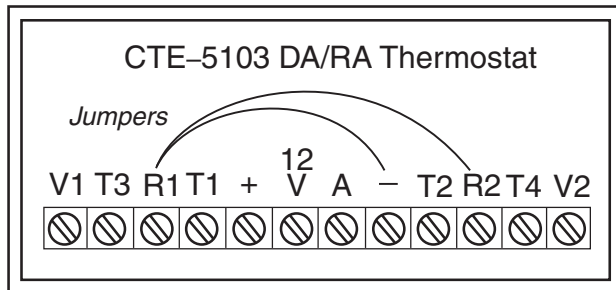
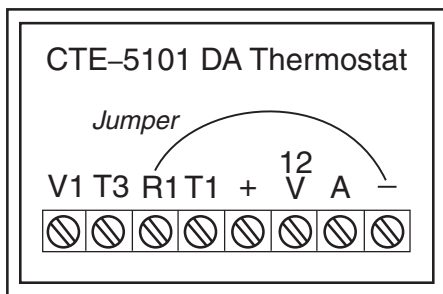

Changing a CTE-5100 Thermostat to a Remote Sensor

A thermostat controller with an external temperature sensor provides a means to remotely locate the temperature sensor in the supply or return air duct or in an area where remote adjustment of the setpoint is desired.

The CTE-5100 series thermostat can be easily modified to accomplish this application. Since the CTE-5100 series thermostats have an averaging temperature input, a thermistor can be wired to this input and the thermostat's thermistor can be removed. **The thermistor is clearly visible once the scale plate is removed, simply clip both leads**

underneath the thermistor to remove it. The remote thermistor is then wired to terminals "+12 V" and to "A" (as shown in chart below).

TTE series remote temperature sensor/transmitters include a three wire sensor with "+", "A", and "-" connections. When the TTE series are used as remote sensors for the CTE-5100 series, only the "+" and "A" connections are used. These two connections are to the thermistor (resistance) only (not a voltage output). The chart below illustrates the various TTE models and the appropriate terminal designations.

CTE-5100 Series Connections for Remote Sensor

Model	Type	"+12 V" Connection	"A" Connection
TTE-1001	Room Sensor	Terminal +	Terminal A
TTE-2001	Duct Sensor	Terminal 1	Terminal 2
TTE-5001/5011	Room Sensor	Terminal B	Terminal A

NOTE: A (Type III thermistor) STE-14xx duct sensor could be substituted for the (Type II thermistor) TTE-2001 since the difference in values would be minor at normal room temperatures.

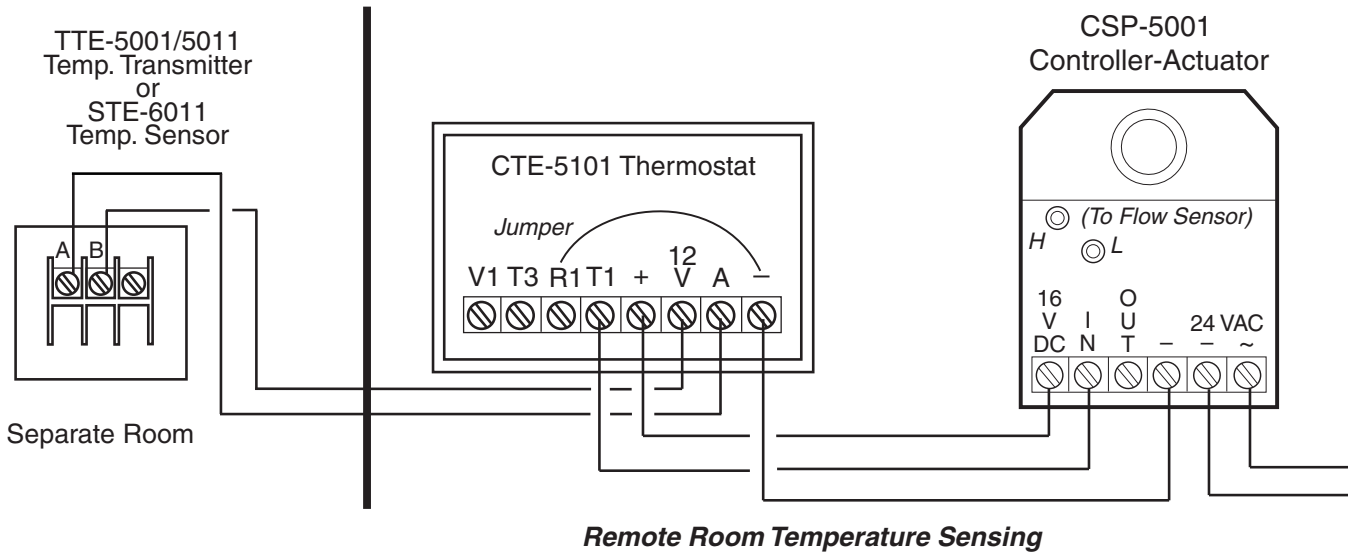
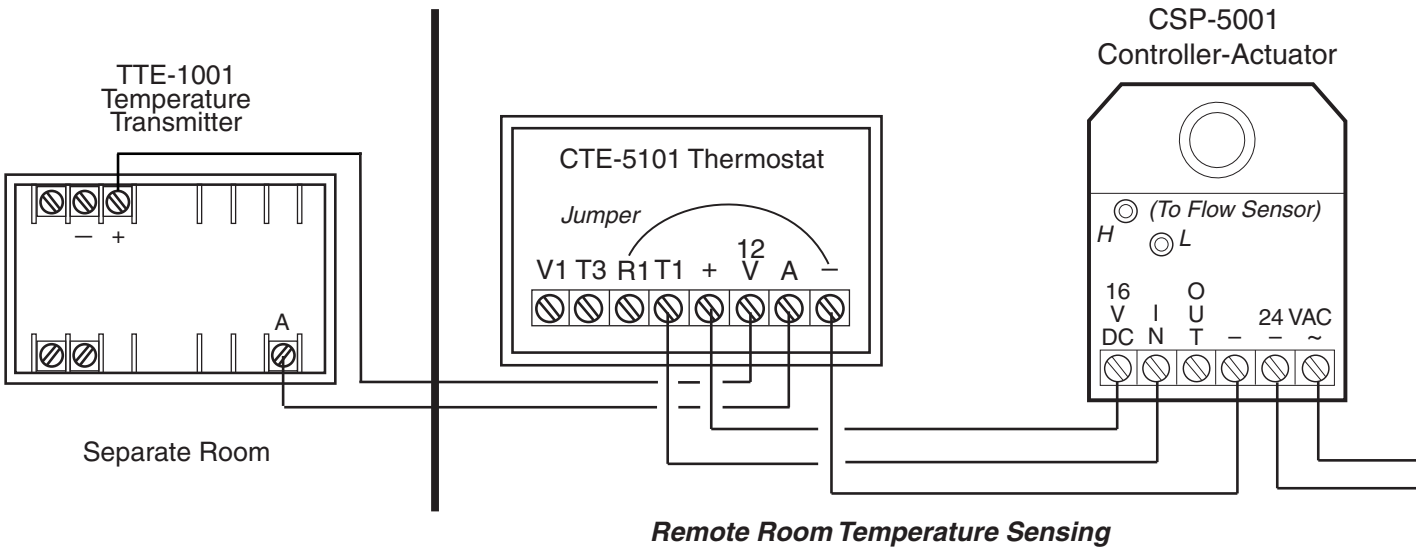
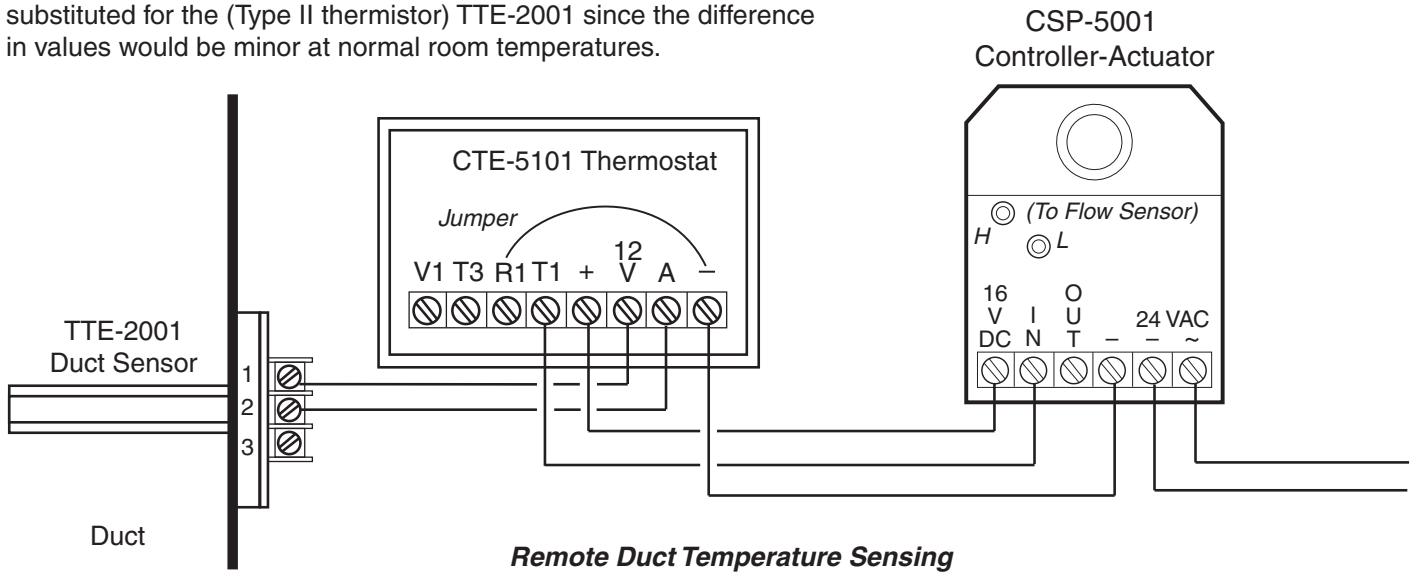

Applications

Cooling or Heating

The CTE-5100 series single-setpoint thermostats are designed for use with CSP-5000 series electronic VAV controllers to operate damper boxes and/or valves in the HVAC system. As shown in the diagram, a “requested flow” voltage signal (T1 or T2) is wired to the CSP-5001 to adjust airflow from minimum to maximum flow according to space demand. Minimum and maximum flow limit adjustments can be made at the thermostat or at the controller.

An additional “unrestricted” output (T3 or T4) is not affected by minimum/maximum limits and can be used to operate reheat equipment or other control devices by utilizing REE series relays (some thermostats vary). See CTE-5100 Series Thermostat Reference section for details on “T” terminals. The CTE-5101 has a Direct Acting (DA) reset and the CTE-5102 employs a Reverse Acting (RA) reset.

(Former Ref. # APE-1-5001)

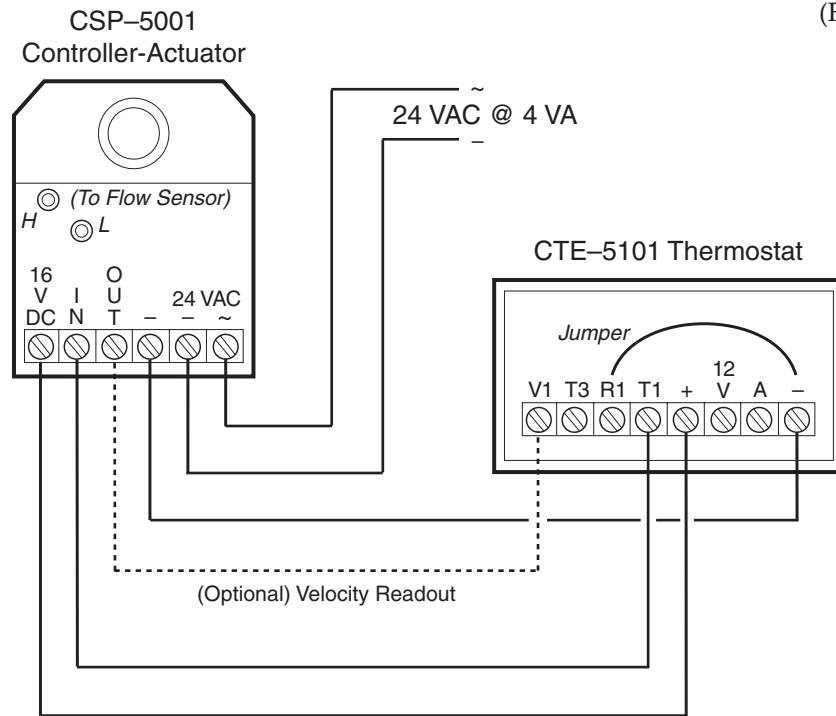

NOTE: CTE-5101 for cooling is shown. For heating, use CTE-5102, with terminal T2 for input (“IN”) signal to CSP-5001 controller.

NOTE: For use with the CTE-5202 thermostat instead of the CTE-5100 series, see the [CTE-5202 Applications Guide](#).

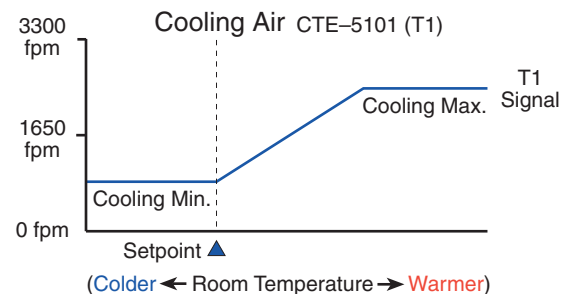
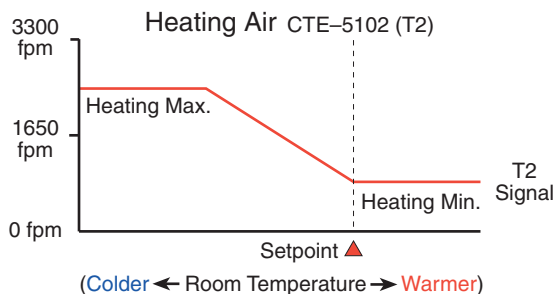

Auto, Override to Fully Closed, or Override to Fully Open

The “Override to Fully Closed” wiring diagram below allows the CTE-5101 thermostat to control the CSP-5001 controller as normal (Auto) or override the flow setting on the CSP-5001 to fully closed.

The SPDT relay switches to select between the two modes (Auto/Fully Closed). In the relay position shown, the controller will override the flow setting. (Jumping “-” and “IN” drives the actuator fully closed.)

When the relay switches, the thermostat will control the VAV box based on demand (Auto).

The “Override to Fully Open” wiring illustration below allows the CTE-5101 thermostat to control the CSP-5001 controller as normal (Auto) or override the flow setting on the CSP-5001 to fully open.

The SPDT relay switches to select between the two modes (Auto/Fully Open). In the relay position shown, the controller will override the flow setting. (Jumping “16 VDC” and “IN” drives the actuator fully open.)

When the relay switches, the thermostat will control the VAV box based on demand (Auto).

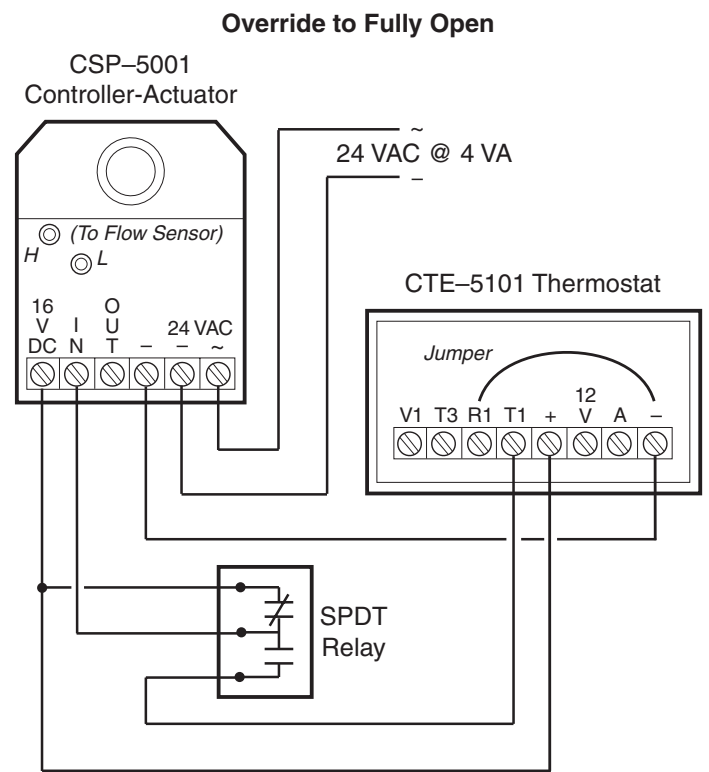
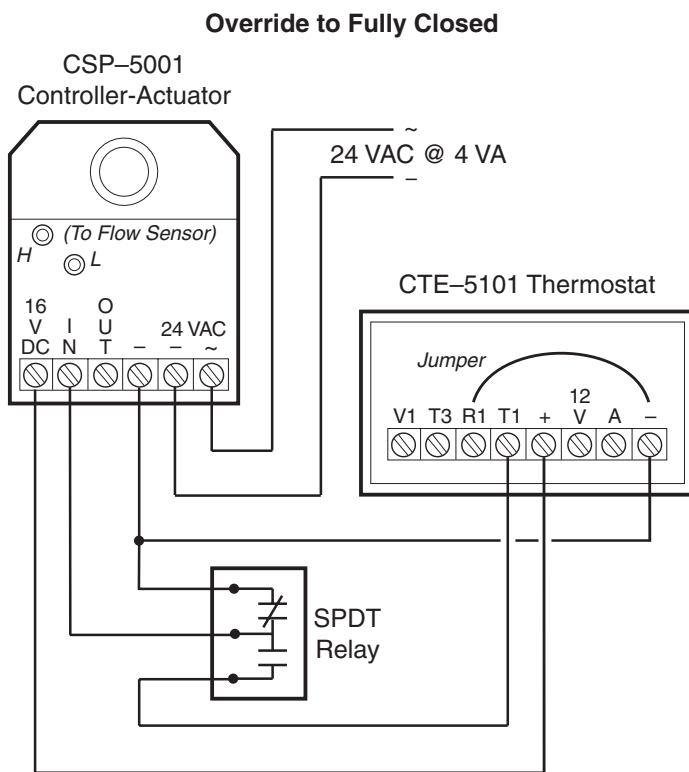

Cooling with 3-Stage Reheat

The CTE-5104 electronic thermostat is a dual-setpoint thermostat for heating (RA) and cooling (DA) applications. The application below uses an REE-5001 relay module and three 24 VAC contactors for three stages of reheat.

The diagram below shows a jumper between "T2" and terminal "R2" on the thermostat to permit auxiliary flow. As the temperature drops below setpoint, the first stage of reheat begins. As the

temperature continues to drop, the second stage begins and so on (see the first chart). This auxiliary flow is used as a second minimum flow before enabling the reheat stages.

When the auxiliary flow is not being used (see the second chart), connect the jumper between terminals "R2" and "-" and turn the auxiliary dial fully CCW to ensure it will have no effect.

(Former Ref. # APE-1-5012)

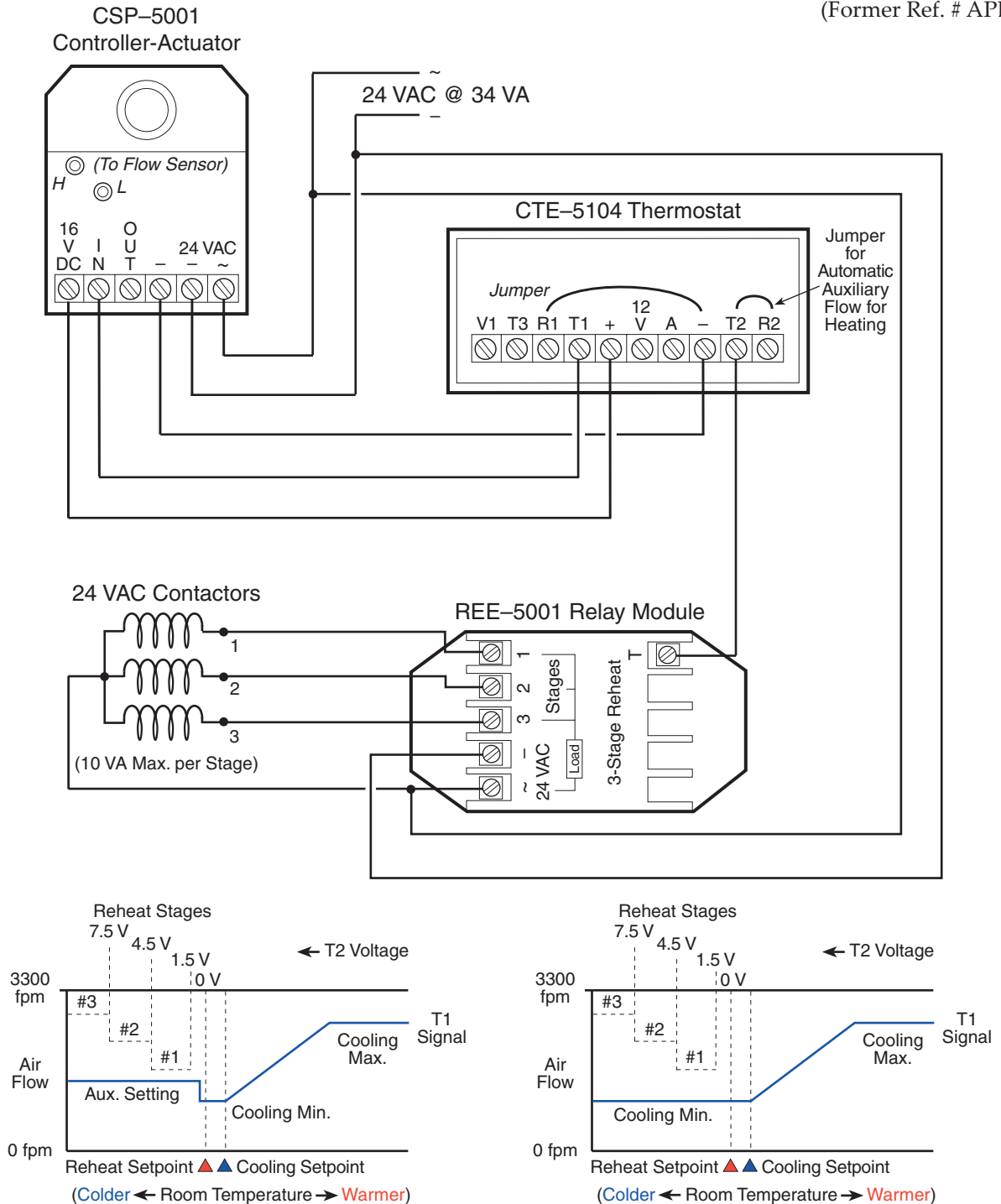

Cooling with 3-Stage Reheat and 10 Degree Night Setback/Setup

This configuration is the same as on the previous page except for the simple addition of a SPST relay or switch and a resistor (see chart below for value).

The switch or relay is driven by a night setback/setup signal from other equipment not shown. When the contact is closed (e.g., by a timer), the added fixed resistance of, for example, 41.2K ohms between thermostat **terminals A and 12V** would indicate that the room is approximately 10° F **warmer** than

it really is. This would inhibit the heat stages from coming on during the unoccupied mode (night setback). If the resistor and switch are instead connected between thermostat **terminals A and -**, the room would seem 10° **cooler** than it really is, inhibiting cooling during unoccupied times.

NOTE: This configuration requires the system fan to be on during setback/setup mode.

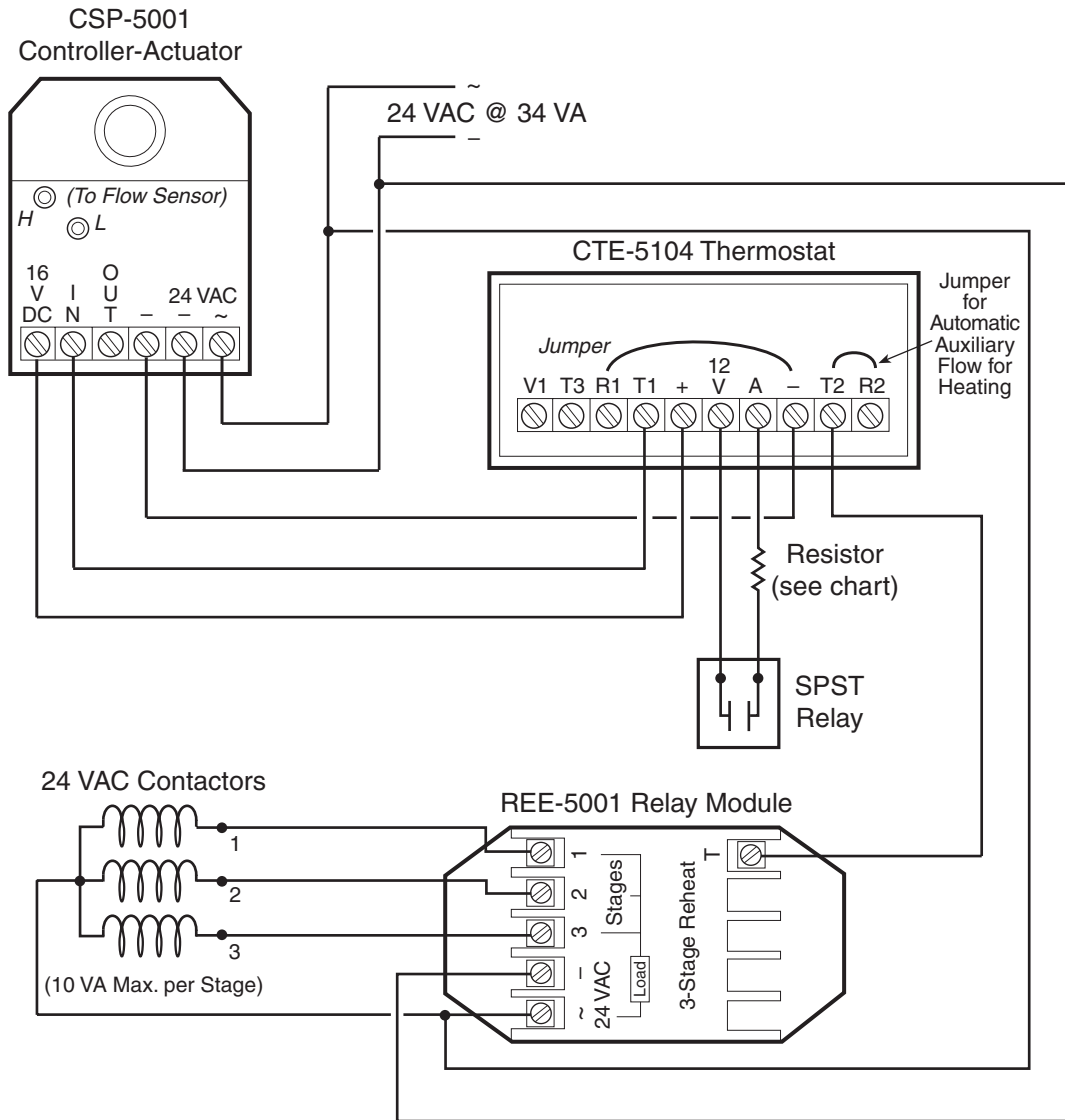

Setback/Setup Resistor Value

Offset	Resistor Ohms (Ideal)	Common 1% Resistor Values	Common 5% Resistor Values
3° F	140.5K	147K	150K
5° F	84.129K	86.6K	82K
8° F	51.23K	52.3K	51K
10° F	40.483K	41.2K	39K
15° F	25.996K	26.1K	27K
20° F	18.267K	18.2K	18K

Cooling with Heating Changeover

The CTE-5103 electronic thermostat is a dual set point thermostat for heating (RA) and cooling (DA) applications. When using an TTE-2001 (or STE-1002/1004) duct sensor and an REE-1005 relay module (as shown below), an automatic changeover is provided for heating/cooling applications. The sensor and relay combination will switch between the "T1" (cooling) or "T2" (heating) signal to the VAV terminal based on the *temperature of the supply air*.

The factory-defined changeover temperature is 77° F ± 4° F. At duct temperature greater than changeover temperature, "T2" is utilized to control heating. Below the changeover, the relay switches allow "T1" to control cooling. At 77°, voltage across terminals "X" and "Y" is approximately 7.75 volts.

NOTE: REE-1005 terminal "A" can be used to trigger an auxiliary setpoint when used with a CTE-5104 or REE-1012. This terminal can also be used to daisy chain more than one REE-1005 together by wiring Terminal "A" to Terminal "Y" on the next relay.

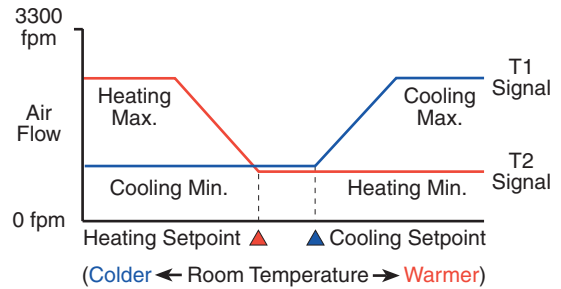

NOTE: Minimums can be set at zero air flow, but a minimum of greater than zero is required for a quick changeover.

(Former Ref. # APE-1-5014)

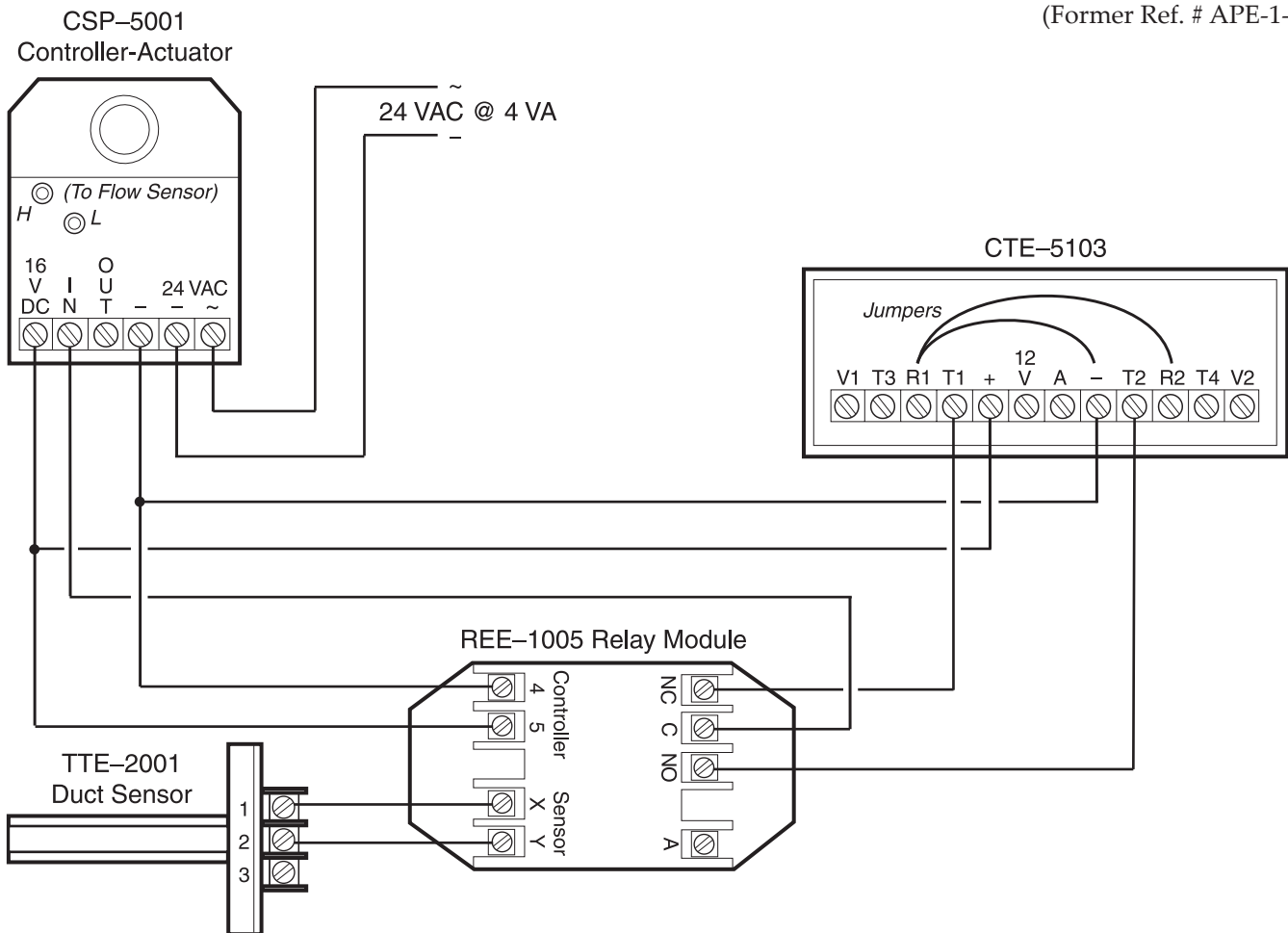

Cooling with Heating Changeover and Electric Reheat

This application utilizes the same controls as Cooling with Heating Changeover but adds the REE-5001 relay for electric reheat. When the VAV inlet air temperature becomes warm (such as morning warm-up), changeover occurs. In this mode, "T2" controls the CSP-5001. The first stage of heat is enabled when the space temperature is slightly above the heating setpoint (3.5 volts). If the temperature continues to drop, the second stage of heat comes on, followed by the third stage. See the chart for reference of each heat stage activation.

NOTE: REE-1005 terminal "A" can be used to trigger an auxiliary flow setpoint when used with a CTE-5104 or REE-1012. This terminal can also be used to daisy chain more than one REE-1005 together by wiring Terminal "A" to Terminal "Y" on the next relay.

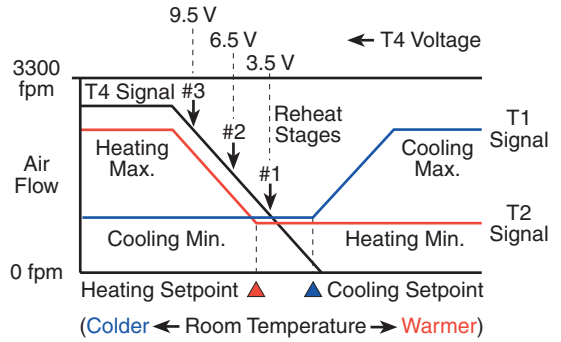

NOTE: Minimums must be sufficient for reheat.

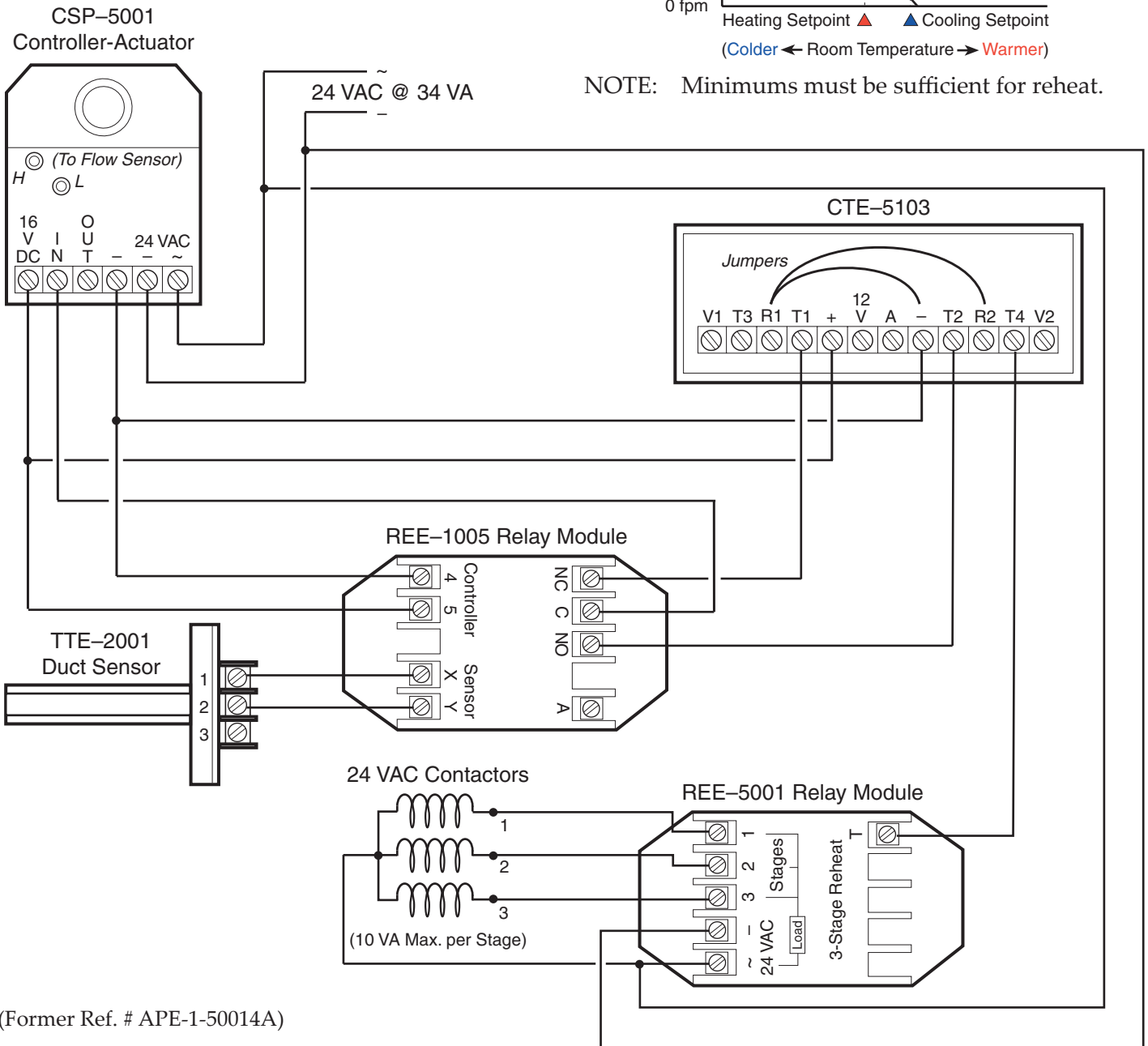

(Former Ref. # APE-1-50014A)

Cooling with Heating Changeover and Hot Water Reheat

This application operates the same as VAV Cooling with Heating Changeover and Electric Reheat except for using a hot water valve instead of electric heating elements for reheat, eliminating the REE-5001 relay.

The valve used in this example is the (discontinued) VEP-15xx0195 2-way valve, which uses a 2–10 VDC signal for control or the 0–10 VDC VEZ-430xxA. When there is hot air in the duct the REE-1005 initiates the changeover, allowing the heating signal from the thermostat to control airflow. When there is a call for heat, the thermostat modulates the HW valve.

NOTE: REE-1005 terminal “A” can be used to trigger an auxiliary flow setpoint when used with a CTE-5104 or REE-1012. This terminal can also be used to daisy chain more than one REE-1005 together by wiring Terminal “A” to Terminal “Y” on the next relay.

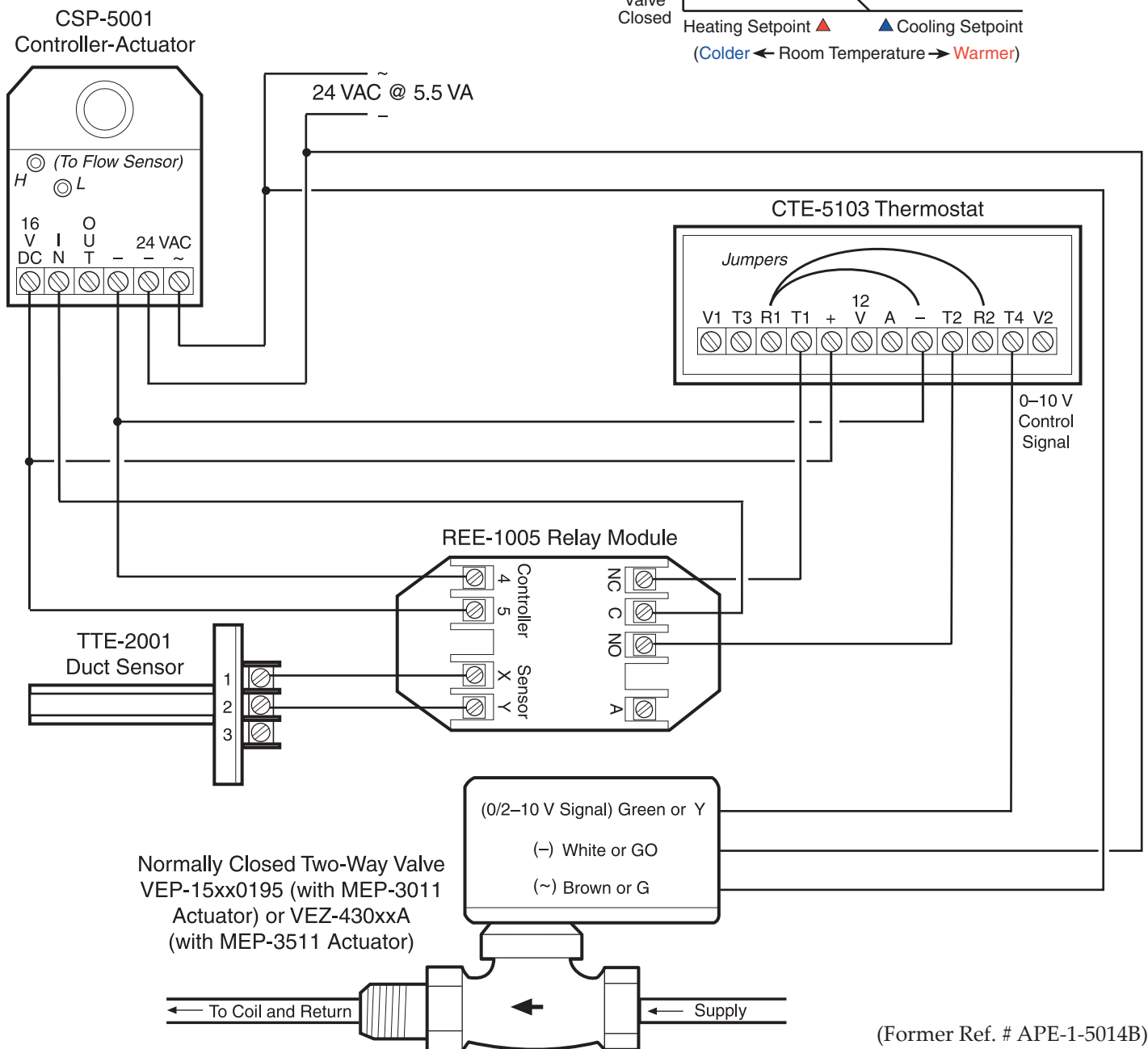
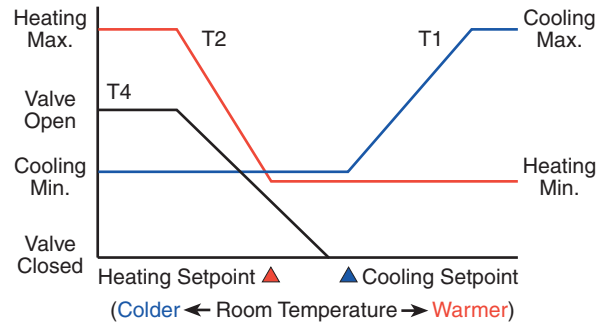

(Former Ref. # APE-1-5014B)

Cooling with Hot Water Reheat

(Former Ref. # APE-1-5017)

This application uses a CTE-5104 thermostat with a VEP-43/VEB-46 series 3-way hot water valve to control temperature in the conditioned space. The valve shown below uses the (discontinued) MEP-5062 or (fail-safe) MEP-5372 actuator for reheat control.

With 0 VDC from the thermostat, the mixing valve bypasses water from the supply to the return. As the thermostat voltage increases, water begins flowing into the coil to allow heated air into the space. At 2° below setpoint the full flow is sent through the coil.

NOTE: Jumper "T2" to "R2" for automatic auxiliary flow for heating.

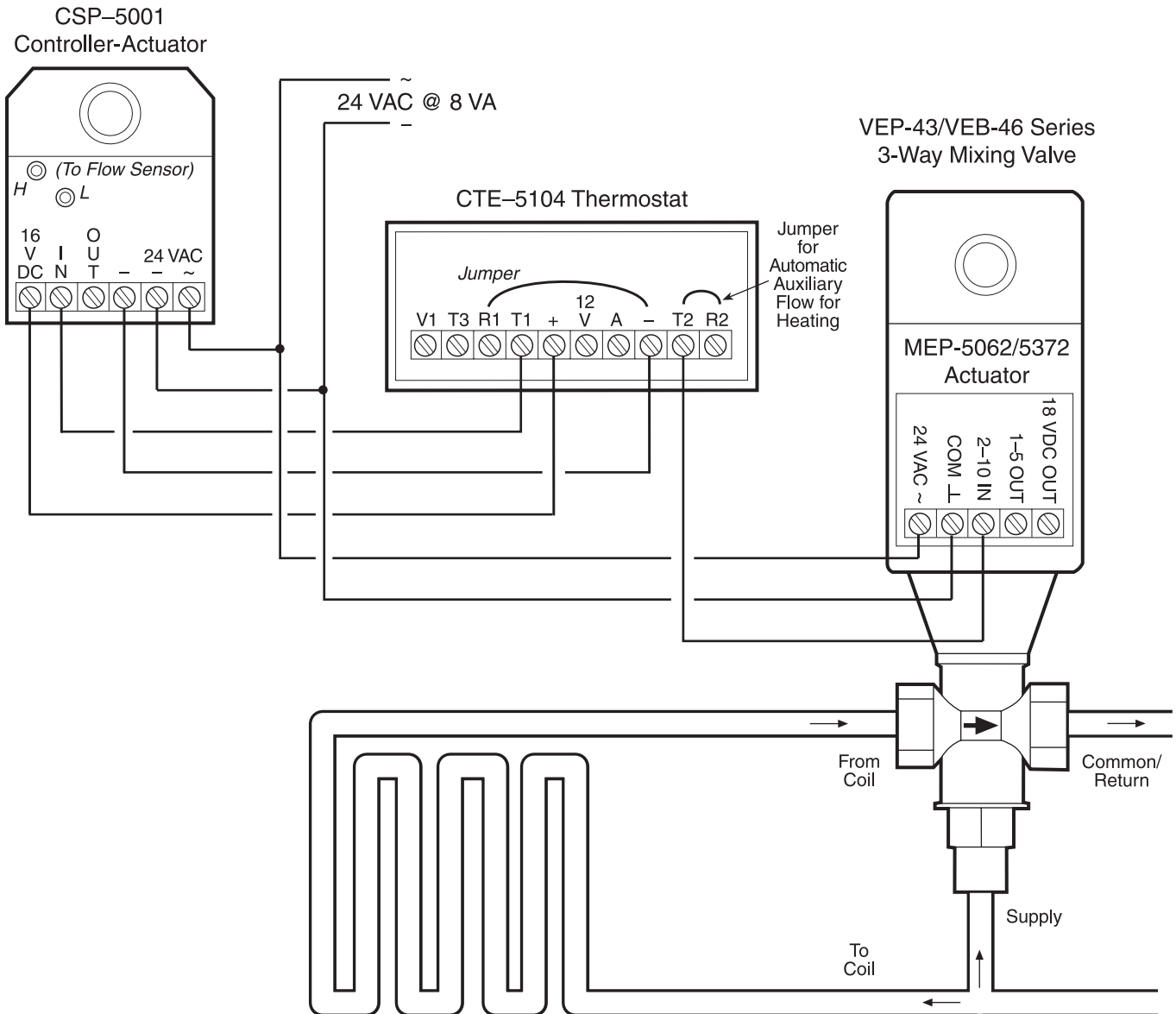
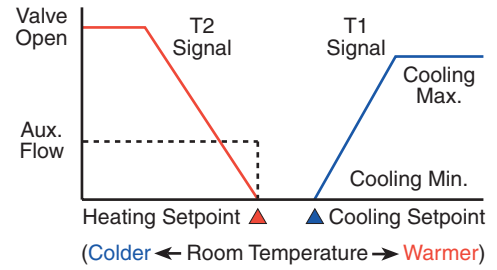

Dual Duct, Minimum Air From Cold Duct

Dual duct applications can use two CSP-5001 series controllers with a dual-setpoint (RA/DA) thermostat, as shown below. In this application the CSP-5001 controllers are mounted separately on the cold and hot air duct dampers with each utilizing its own flow sensor.

The cold-deck controller receives the "T1" signal from the thermostat while the hot-deck controller receives its requested flow signal from "T2." Both units can be set independently for minimum and maximum flow settings. In addition, by using the "R1" or "R2" override terminal on the thermostat, minimum flow can be overridden to zero upon a call for heating (or vice-versa).

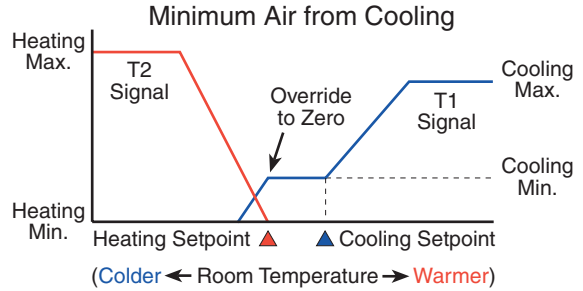

NOTE: Connect jumper from T2 to R1 (shown) to override cooling minimum to zero, upon call for heating. Connect R2 to ground (-).

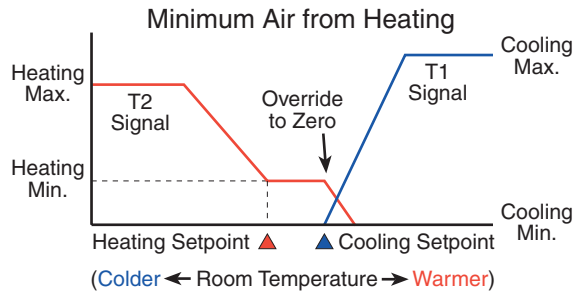

NOTE: Connect jumper from T1 to R2 (not shown) to override heating minimum to zero upon call for cooling. Connect R1 to ground (-).

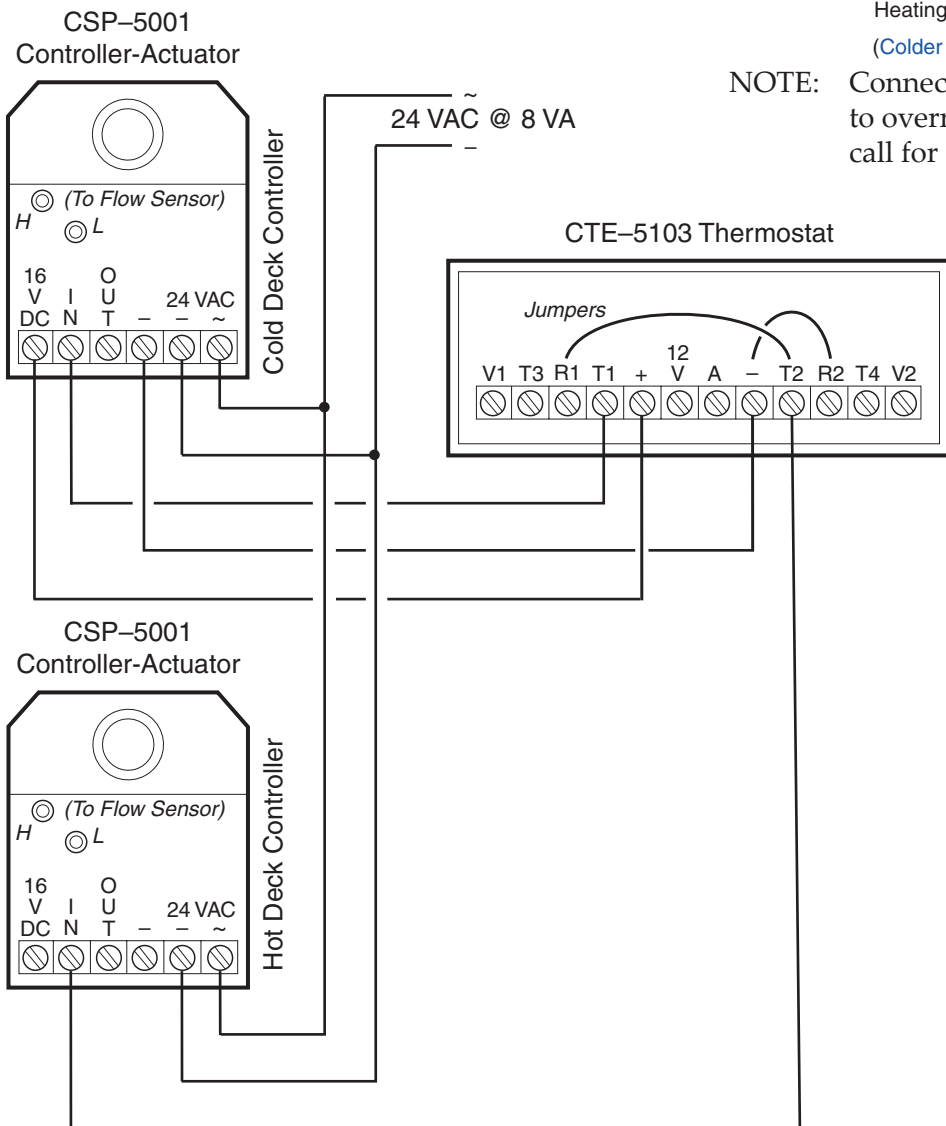

(Former Ref. # APE-2-5001)

Fan Induction with 2-Stage Electric Heat

(Former Ref. # APE-3-5001)

The CTE-5101 electronic thermostat is a single-setpoint thermostat for cooling (DA). In this application, the thermostat is used with the REE-5002 relay module, a fan, and two coils (for two stages of reheat). The REE-5002 was designed primarily for use with VAV fan-powered induction boxes.

If the thermostat drops below setpoint, the relay senses the decrease in voltage and starts the fan. As the temperature continues to drop, the first stage of reheat begins, and the second stage of reheat follows if the thermostat is still not satisfied. The process reverses as the room temperature begins to rise.

NOTE: The "X" Terminal is used for measuring fan trip voltage only.

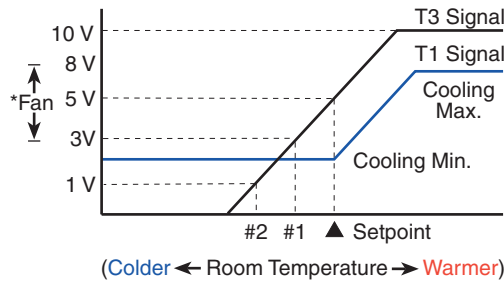

NOTE: The fan has an adjustable start point between 3 and 8 volts.

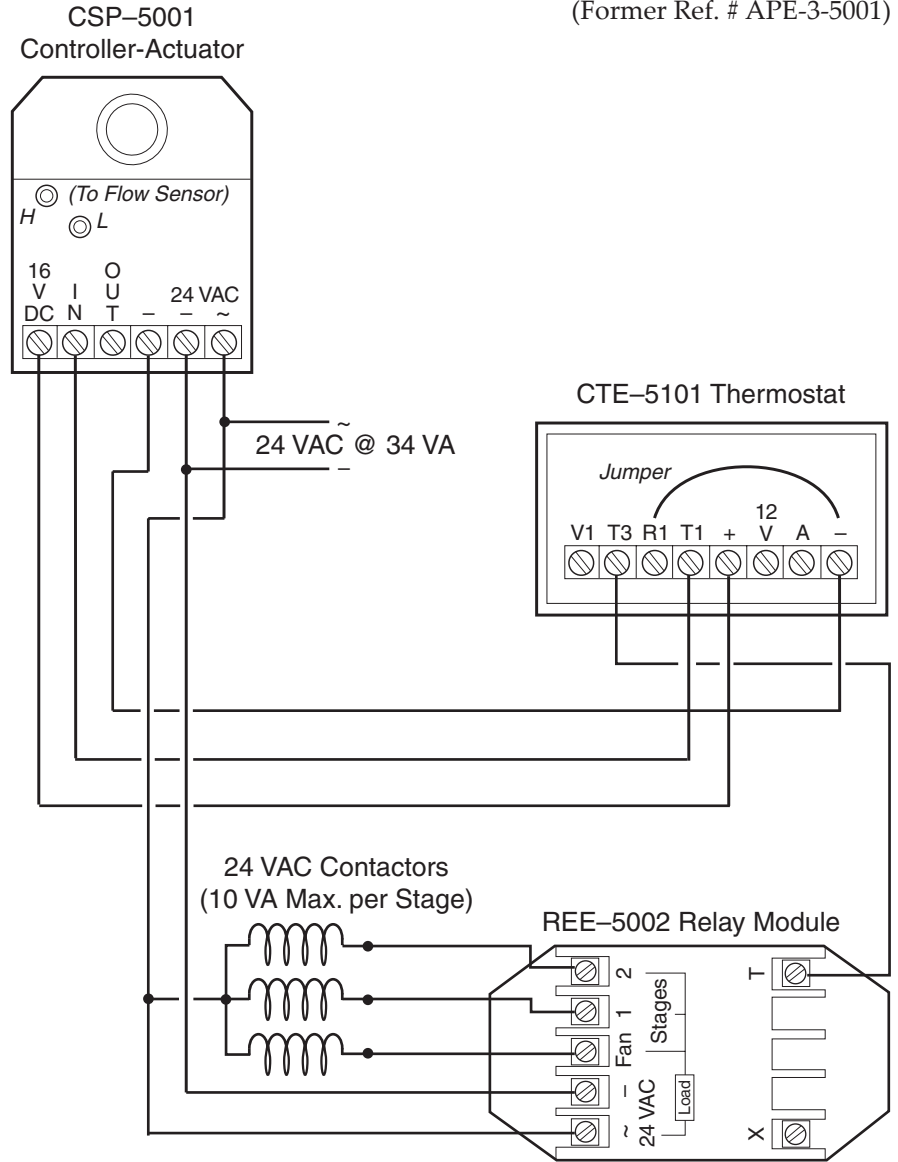

Index

A

Air Flow Sensor **4**
Applications **11**
Auto, Override to Fully Closed, or Override to Fully Open **12**

C

Calibration **7**
CCW vs. CW Rotation **2**
CFM **6**
Changeover **15, 16, 17**
Checkout **7**
Cooling or Heating **11**
Cooling with 3-Stage Reheat **13**
Cooling with 3-Stage Reheat and 10 Degree Night Setback/Setup **14**
Cooling with Heating Changeover **15**
Cooling with Heating Changeover and Electric Reheat **16**
Cooling with Heating Changeover and Hot Water Reheat **17**
Cooling with Hot Water Reheat **18**
Cross-Reference, Thermostat **8**
CTE-5100 Series Cross-reference **8**
CTE-5101 **11, 12, 20**
CTE-5102 **11**
CTE-5103 **15, 19**
CTE-5104 **13, 14, 18**

D

Dual Duct, Minimum Air From Cold Duct **19**

F

Fan Induction with 2-Stage Electric Heat **20**
Flow Limits **6**
Flow Sensor **3**

L

Limits **6**

M

Minimum and Maximum Flow Limits **6**

O

Override **12**

R

REE-1005 **15, 16, 17**
REE-5001 **13, 14, 16, 17**
REE-5002 **20**
Reheat **13, 14, 16, 17, 18, 20**
Remote Sensor **9**
Rotation **2, 3, 4**

S

SSS-100x **3**
STE-100x **15**

T

Testing **5**
Thermostat **7**
Troubleshooting **5**
TTE-2001 **15**
TTE Series **9**

V

Valve **18**
VNOM (CFM) Range Setting **6**
Voltage/Velocity Chart **3**

W

Wiring **4**

NOTE: For use with the CTE-5202 thermostat instead of the CTE-5100 series, see the **CTE-5202 Applications Guide**.

KMC Controls, Inc.
19476 Industrial Drive
New Paris, IN 46553
574.831.5250
www.kmcccontrols.com
info@kmcccontrols.com