

# ANEMOSTAT<sup>®</sup>

## AIR TERMINAL CONTROLS

### Control Package

# SD-D-AT14

- SINGLE DUCT
- ELECTRIC HEAT - SCR CONTROL
- DIRECT DIGITAL CONTROLS (DDC) BY ALERTON
- DDC SUPPLIED TO FACTORY FOR INSTALLATION

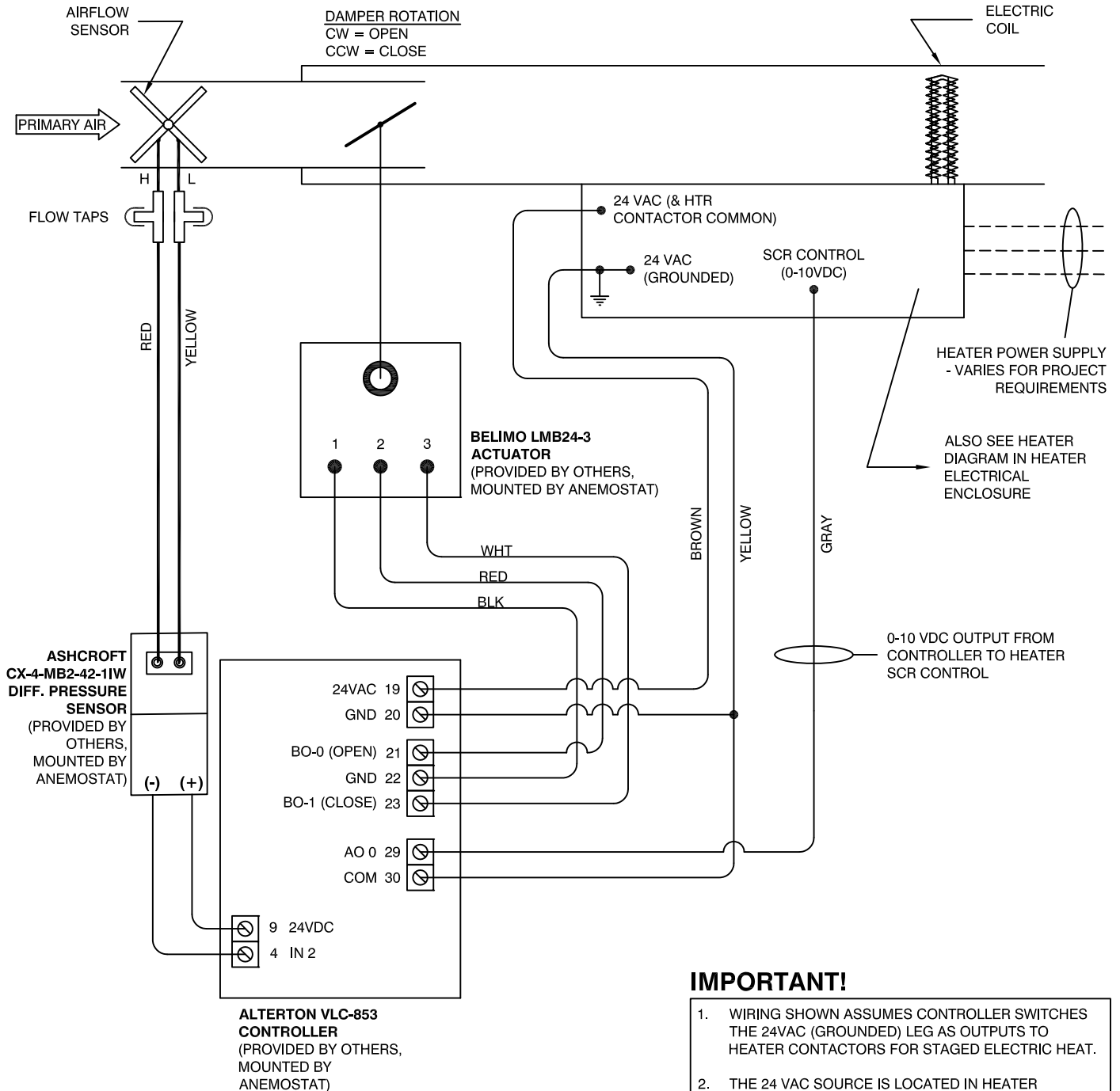

### IMPORTANT!

1. WIRING SHOWN ASSUMES CONTROLLER SWITCHES THE 24VAC (GROUNDED) LEG AS OUTPUTS TO HEATER CONTACTORS FOR STAGED ELECTRIC HEAT.
2. THE 24 VAC SOURCE IS LOCATED IN HEATER ENCLOSURE AND IS SIZED TO HANDLE HEATER CONTACTOR LOAD + 15VA OVERHEAD FOR CONTROLLER AND ACTUATOR.
3. CONSULT CONTROLS DOCUMENTATION FOR DETAILS AS INSTALLED HARDWARE WILL VARY FROM THAT SHOWN HERE.

**JOB NAME:**  
**SUBMITTED BY:**  
**DATE:**

**DWG #:** SD-D-AT14  
**REV:** -  
**DATE:** 5-25-17