

ANEMOSTAT[®]

AIR TERMINAL CONTROLS

Control Package

SD - A - 5222

- SINGLE DUCT
- ANALOG ELECTRONIC CONTROLS
- VAV COOLING & HOT WATER HEAT (2-POSITION)
- PRESSURE INDEPENDENT
- AIR FLOW SETPOINTS ADJUSTED AT THERMOSTAT
- EARLY MORNING WARM-UP (COIL LOCK OUT)

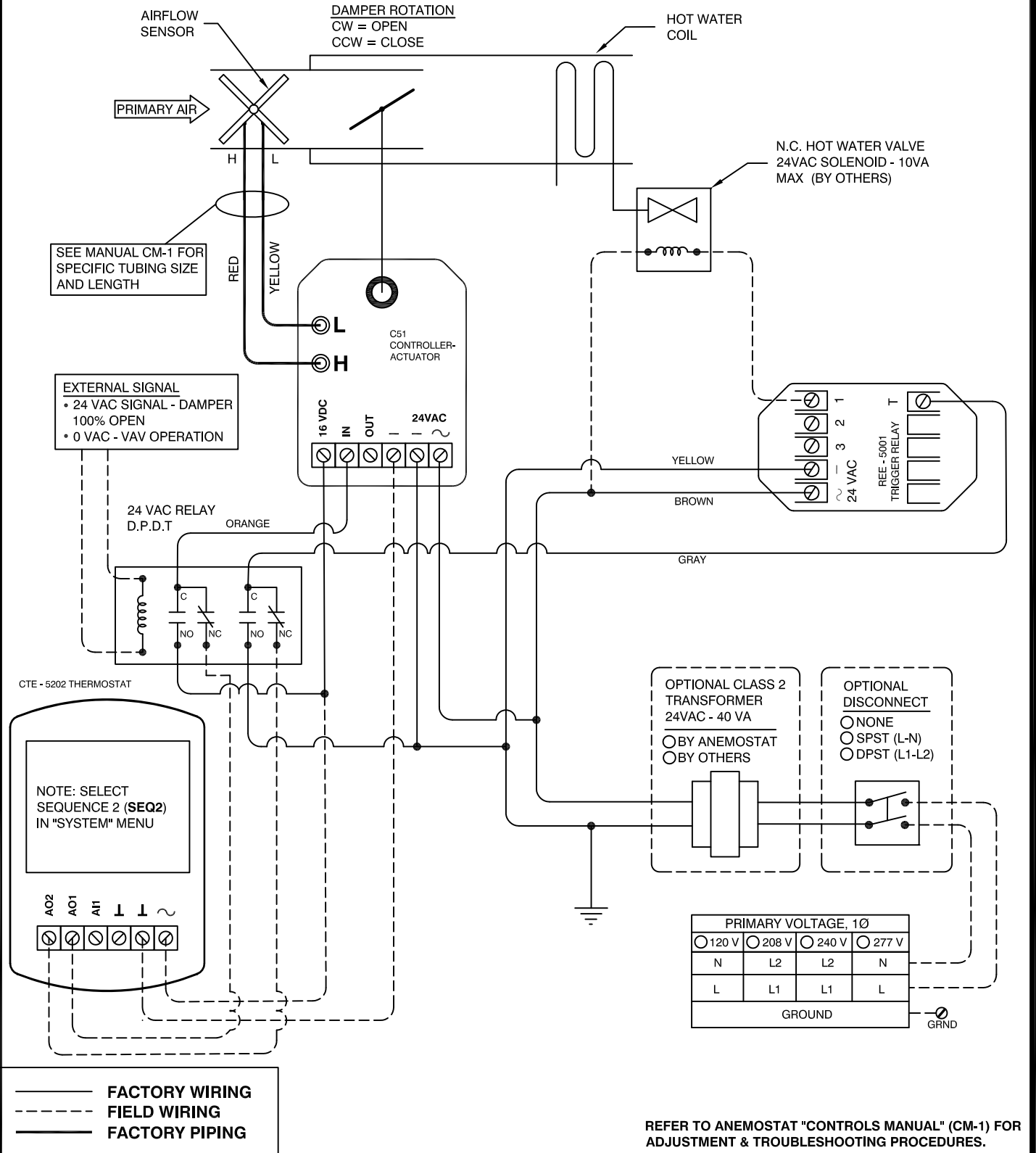

JOB NAME:
SUBMITTED BY:
DATE:

DWG #: SD-A-5222.1
REV: -
DATE: 3-3-2017

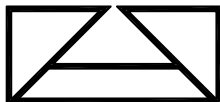

- SINGLE DUCT
- ANALOG ELECTRONIC CONTROLS
- VAV COOLING & HOT WATER HEAT (2-POSITION)
- EARLY MORNING WARM-UP (COIL LOCK OUT)
- PRESSURE INDEPENDENT
- AIR FLOW SETPOINTS ADJUSTED AT THERMOSTAT

VAV OPERATION

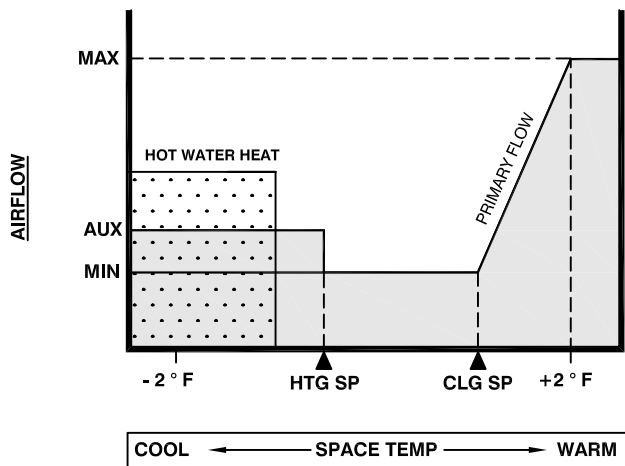

MORNING WARMUP (COIL LOCKED OUT)

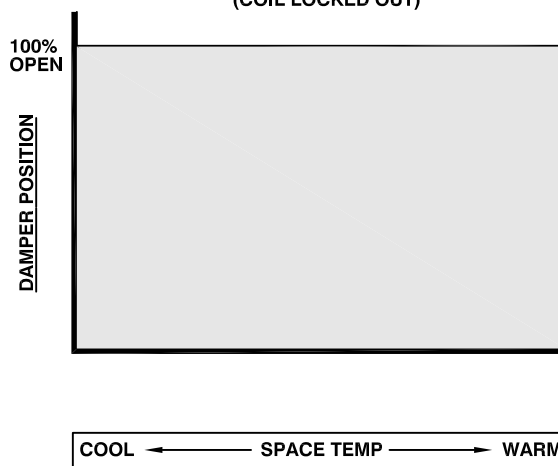

SEQUENCE OF OPERATION

1. THE THERMOSTAT SIGNALS THE CONTROLLER IN RESPONSE TO THE SPACE TEMPERATURE, AND INCLUDES BOTH A COOLING AND HEATING SETPOINT SLIDER.
2. AS THE SPACE TEMPERATURE INCREASES FROM THE COOLING SETPOINT TO +2° F ABOVE THE COOLING SETPOINT, THE DAMPER OPENS FROM MINIMUM AIRFLOW TO MAXIMUM AIRFLOW. ABOVE (CLG SP + 2° F), THE DAMPER MAINTAINS MAXIMUM FLOW.
3. MINIMUM AIRFLOW IS MAINTAINED WHEN THE SPACE TEMPERATURE IS BETWEEN THE HEATING AND COOLING SETPOINTS.
4. WHEN THE SPACE TEMPERATURE HITS THE HEATING SETPOINT, AND IF THERMOSTAT JUMPER T2-R2 IS IN PLACE, THEN THE AIRFLOW RATE IS INDEXED TO THE AUX AIRFLOW SETPOINT. IF THE JUMPER IS REMOVED, THEN THE AIRFLOW RATE IS MAINTAINED AT MINIMUM.
5. THE HOT WATER VALVE IS OPENED AS THE SPACE TEMPERATURE DROPS FROM THE HEATING SETPOINT DOWN TO (HTG SP - 2° F)
6. IN MORNING WARM-UP MODE (EXTERNAL SIGNAL = 24VAC), THE DAMPER IS DRIVEN 100% OPEN POSITION, AND THE COIL IS LOCKED OUT. FLOW IS NOT CONTROLLED, AND WILL VARY BASED ON AVAILABLE DUCT PRESSURE (PRESSURE DEPENDENT).
7. THE MINIMUM, MAXIMUM, AND AUX AIRFLOW SETPOINTS ARE ADJUSTED AT THE THERMOSTAT.
8. UPON LOSS OF POWER, DAMPER FAILS IN PLACE.

JOB NAME:
SUBMITTED BY:
DATE:

DWG #: SD-A-5222.2
REV: -
DATE: 9-30-08