

ANEMOSTAT[®]

AIR TERMINAL CONTROLS

Control Package

FS - A - 5201

- SERIES FAN AIR TERMINAL
- ELECTRIC HEAT - STEP CONTROL

- ANALOG ELECTRONIC CONTROLS

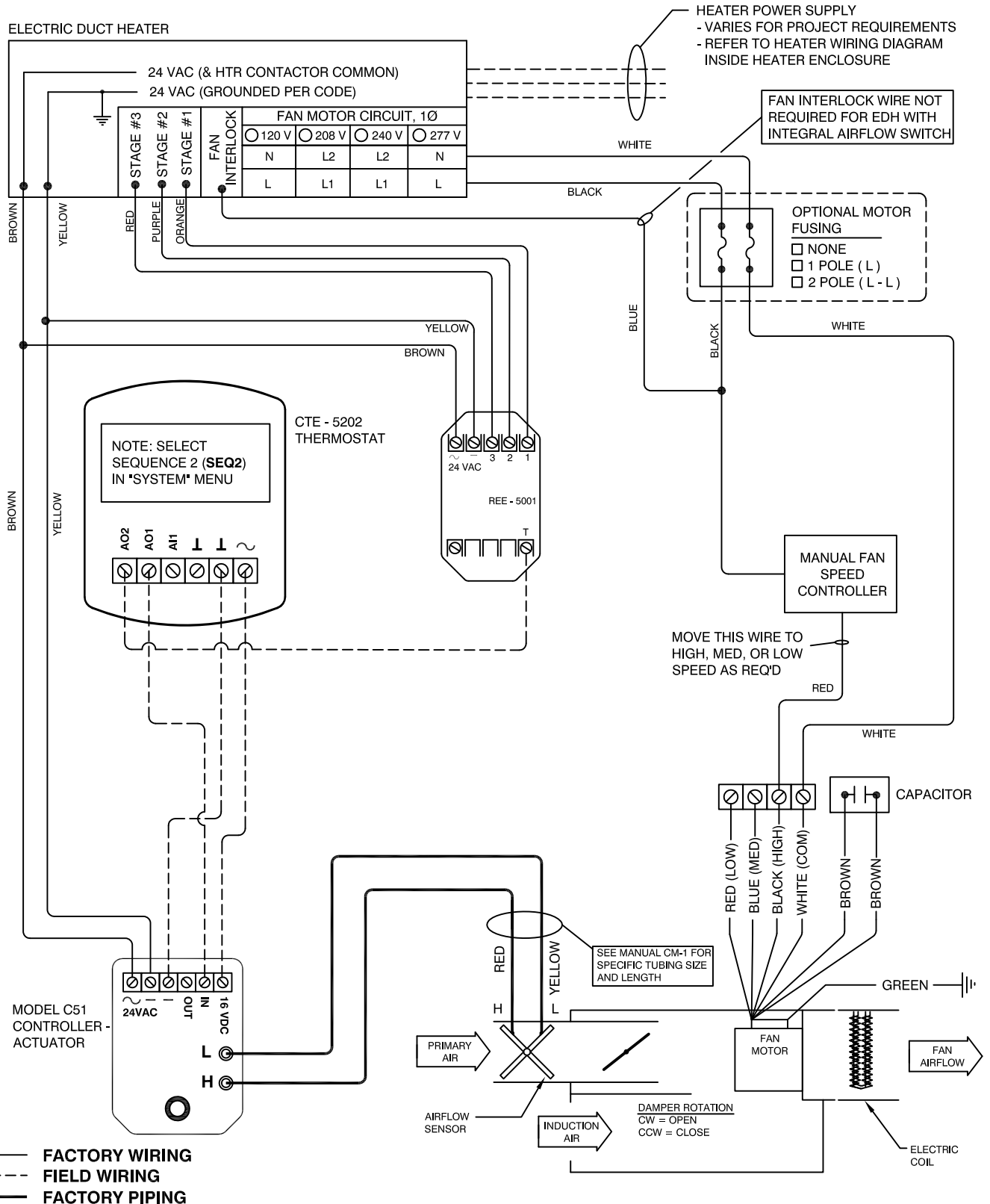

JOB NAME:
SUBMITTED BY:
DATE:

DWG #: FS-A-5201
REV: -
DATE: 6-5-17