

ANEMOSTAT[®]

SERIES FAN AIR TERMINAL

Control Package
ES - D - 8004A

- ENERGY SMART EC MOTOR
- BACNET DIGITAL CONTROLS
- VAV COOLING & ELECTRIC HEAT (STEP CONTROL)
- DIGITAL SENSOR STE-8001W80

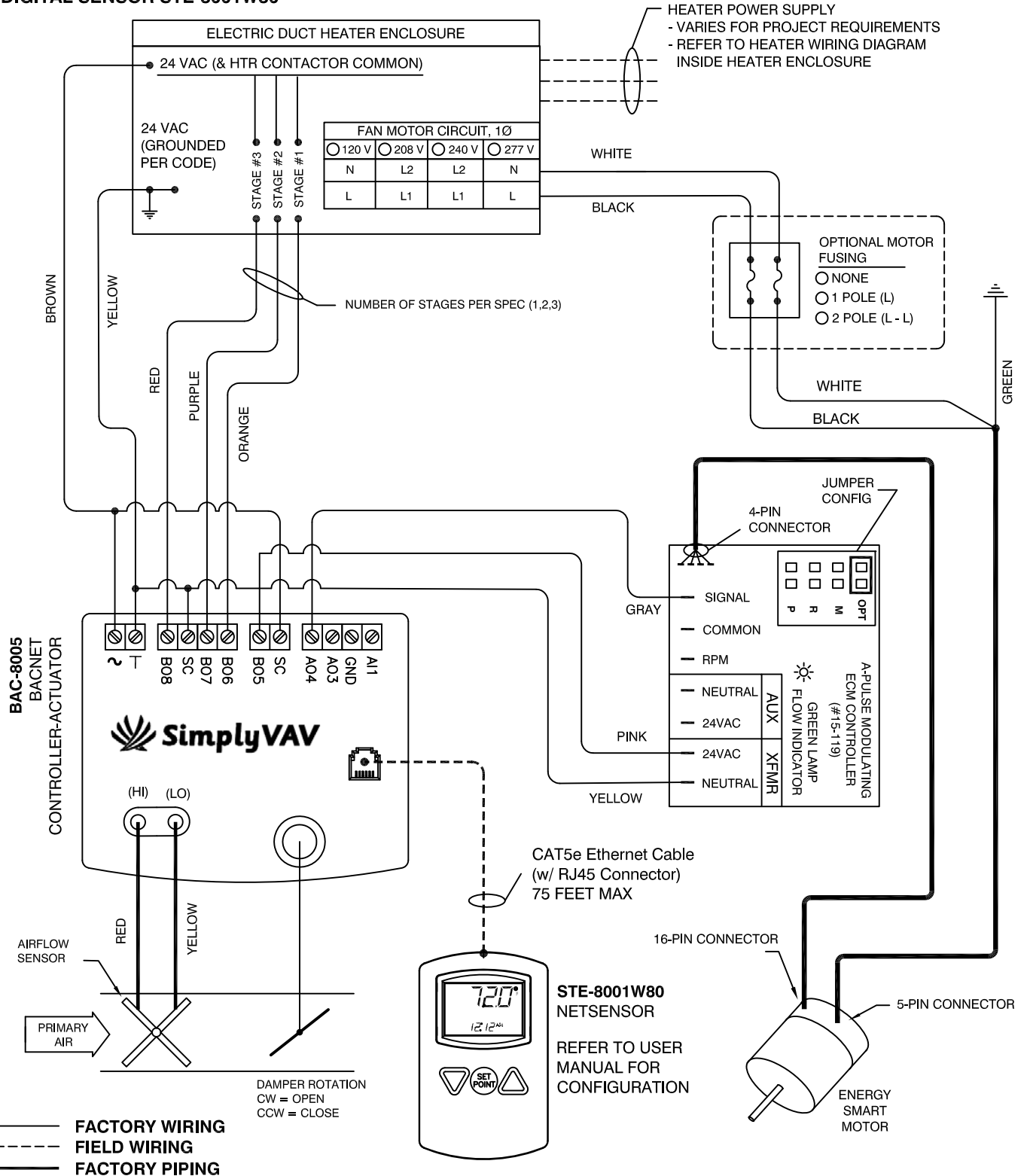

JOB NAME:
SUBMITTED BY:
DATE:

DWG #: ES-D-8004A.1
REV: B
DATE: 03-24-17

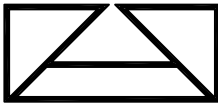

ANEMOSTAT[®]

SERIES FAN AIR TERMINAL

Control Package
ES - D - 8004A

- ENERGY SMART EC MOTOR
- BACNET DIGITAL CONTROLS
- VAV COOLING & ELECTRIC HEAT (STEP CONTROL)
- DIGITAL SENSOR STE-8001W80

OCCUPIED MODE (AHU ON)

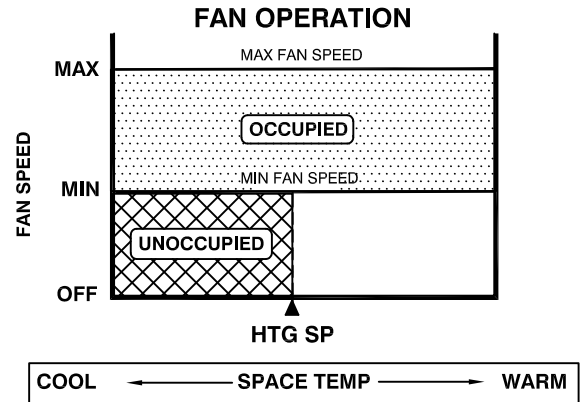
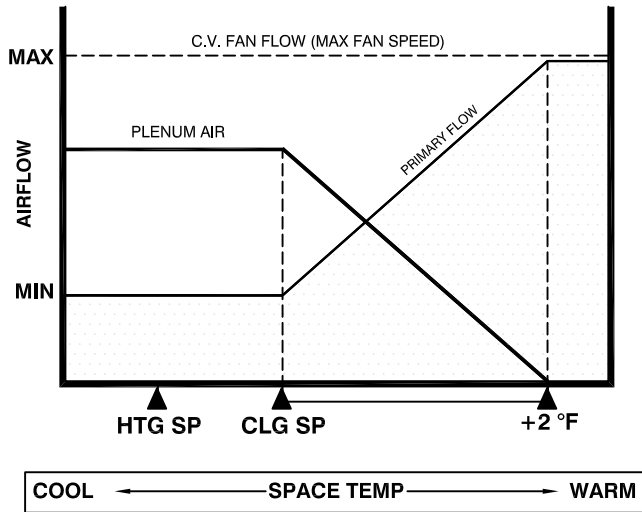

STEP HEAT SEQUENCE

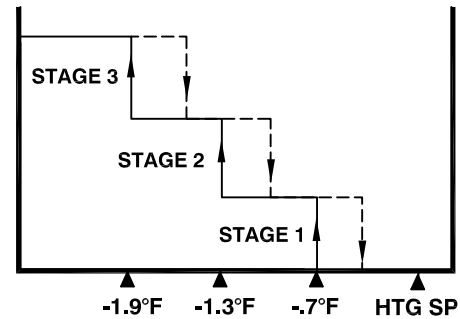

SEQUENCE OF OPERATION

THE AIR TERMINAL FAN MUST BE RUNNING TO DELIVER AIR TO THE SPACE. THE CONSTANT VOLUME FAN CFM MUST BE GREATER THAN THE MAXIMUM PRIMARY CFM TO PREVENT SPILLING OF AIR INTO THE CEILING PLENUM. FAN CFM = PRIMARY CFM + INDUCED CFM

ALL SET POINTS ARE ADJUSTABLE AT THE WALL SENSOR. SEE SENSOR USER MANUAL FOR DETAILS.

OCCUPIED MODE (AHU ON)

1. THE CONTROLLER RECOGNIZES AIR FLOW (AT LEAST 30% OF FLOW DEMAND) TO PUT THE CONTROLS INTO THE OCCUPIED MODE. THE FAN SPEED IS INDEXED TO THE MAX FAN SPEED SETTING. THE WALL SENSOR SIGNALS THE CONTROLLER IN RESPONSE TO THE SPACE TEMPERATURE.
2. AS THE SPACE TEMP INCREASES FROM THE COOLING SET POINT TO +2° F ABOVE THE SET POINT, THE DAMPER OPENS FROM MIN TO MAX AIR FLOW. OVER +2° F ABOVE THE SET POINT, THE DAMPER MAINTAINS MAX FLOW. BELOW SET POINT, MIN AIR FLOW IS MAINTAINED.
3. AS THE SPACE TEMP DECREASES BELOW HEATING SET POINT TO -2° F BELOW THE SET POINT, UP TO 3 STAGES OF ELECTRIC HEAT (1,2,3) ARE ENERGIZED RESPECTIVELY. AS THE SPACE TEMPERATURE RISES BACK TOWARD THE HEATING SET POINT, HEATING STAGES (3,2,1) ARE TURNED OFF RESPECTIVELY.

UNOCCUPIED MODE (AHU OFF)

1. UNOCCUPIED MODE OCCURS WHEN THE CONTROLLER DELIVERS LESS THAN 25% OF FLOW DEMAND FOR AT LEAST 5 MINUTES.
2. THE FAN STARTS @ MIN FAN SPEED SETTING ON A CALL FOR HEATING BASED ON THE HEATING SET POINT TEMPERATURE.
3. AS THE SPACE TEMP DECREASES BELOW HEATING SET POINT TO -2° F BELOW THE SET POINT, UP TO 3 STAGES OF ELECTRIC HEAT (1,2,3) ARE ENERGIZED RESPECTIVELY. AS THE SPACE TEMPERATURE RISES BACK TOWARD THE HEATING SET POINT, HEATING STAGES (3,2,1) ARE TURNED OFF RESPECTIVELY.
3. ABOVE THE HEATING SET POINT TEMPERATURE, THE FAN TURNS OFF.
4. THE PRIMARY DAMPER WILL REMAIN 100% OPEN IN THE UNOCCUPIED MODE.

UPON LOSS OF POWER, PRIMARY DAMPER FAILS IN PLACE. OCCUPANCY MODES CAN BE DISABLED IF DESIRED.

JOB NAME:
SUBMITTED BY:
DATE:

DWG #: ES-D-8004A.2
REV: B
DATE: 03-24-17